



## USER INSTRUCTIONS

### **Flowserve® CPXV-E**

Enclosed column version of CPXV vertical sump pump

PCN=87900056 12-15 (E). Original instructions.

---

***Installation  
Operation  
Maintenance***



***These instructions must be read prior to installing,  
operating, using and maintaining this equipment.***

***Experience In Motion***

**CONTENTS**

	<b>Page</b>		<b>Page</b>
1 INTRODUCTION AND SAFETY .....	4	6 MAINTENANCE .....	20
1.1 General .....	4	6.1 General .....	20
1.2 CE marking and approvals .....	4	6.2 Maintenance schedule .....	21
1.3 Disclaimer .....	4	6.3 Spare parts .....	21
1.4 Copyright .....	4	6.4 Recommended spares .....	22
1.5 Duty conditions .....	4	6.5 Tools required .....	22
1.6 Safety .....	5	6.6 Casing, seal housing and fastener torques ...	22
1.7 Nameplate and safety labels .....	9	6.7 Setting impeller clearance .....	22
1.8 Specific machine performance .....	9	6.8 Renewal clearances .....	24
1.9 Noise level .....	9	6.9 Disassembly .....	24
2 TRANSPORT AND STORAGE .....	10	6.10 Examination of parts .....	26
2.1 Consignment receipt and unpacking .....	10	6.11 Assembly .....	26
2.2 Handling .....	10	7 FAULTS; CAUSES AND REMEDIES .....	28
2.3 Lifting .....	10	8 PARTS LISTS AND DRAWINGS .....	30
2.4 Storage .....	11	8.1 CPXV-E .....	30
2.5 Recycling and end of product life .....	11	8.2 CPXV-E bearing options .....	32
3 DESCRIPTION .....	11	8.3 Optional A-OP key-drive impeller .....	32
3.1 Configurations .....	11	8.4 Parts interchangeability .....	33
3.2 Name nomenclature .....	11	8.5 General arrangement drawing .....	33
3.3 Design of major parts .....	12	9 CERTIFICATION .....	33
3.4 Performance and operating limits .....	12	10 OTHER RELEVANT DOCUMENTATION AND MANUALS .....	33
4 INSTALLATION .....	13	10.1 Supplementary User Instruction manuals ...	33
4.1 Location .....	13	10.2 Change notes .....	33
4.2 Part assemblies .....	13	10.3 Additional sources of information .....	33
4.3 Foundation .....	13		
4.4 Grouting .....	13		
4.5 Piping .....	13		
4.6 Electrical connections .....	15		
4.7 Protection systems .....	15		
5 COMMISSIONING, START-UP, OPERATION AND SHUTDOWN .....	16		
5.1 Pre-commissioning procedure .....	16		
5.2 Pump lubricants and coolants .....	16		
5.3 Open impeller clearance .....	18		
5.4 Direction of rotation .....	18		
5.5 Guarding .....	18		
5.6 Priming and auxiliary supplies .....	18		
5.7 Starting the pump .....	18		
5.8 Running the pump .....	19		
5.9 Stopping and shutdown .....	19		
5.10 Hydraulic, mechanical and electrical duty ...	20		

**INDEX**

	Page	Page	
Additional sources (10.3) .....	33	Reassembly (6.11, Assembly) .....	26
Assembly (6.11).....	26	Receipt and unpacking (2.1).....	10
ATEX marking (1.6.4.2).....	7	Recommended fill quantities (see 5.2.2) .....	17
Bearing sizes and capacities (5.2.2).....	17	Recommended grease lubricants (5.2.3) .....	17
CE marking and approvals (1.2).....	4	Recommended oil lubricants (5.2.1) .....	16
Certification (9) .....	46	Recommended spares (6.4) .....	22
Change notes (10.2) .....	33	Recycling (2.5) .....	11
Clearances, impeller (6.7) .....	22	Replacement parts (6.3 and 6.4).....	21/22
Commissioning and operation (5).....	16	Running the pump (5.8).....	19
Compliance, ATEX (1.6.4.1).....	6	Safety action (1.6.3) .....	5
Configurations (3.1) .....	11	Safety labels (1.7.2) .....	9
Copyright (1.4).....	4	Safety markings (1.6.1) .....	5
Design of major parts (3.3).....	12	Safety, protection systems (1.6 and 4.7)	
Direction of rotation (5.4).....	18	Sectional drawings (see 8) .....	30
Disassembly (6.9) .....	24	Setting impeller clearance (6.7) .....	22
Disclaimer (1.3).....	4	Sound pressure level (1.9, Noise level).....	9
Dismantling (6.9, Disassembly) .....	24	Sources, additional information (10.3).....	33
Drawings (8) .....	30	Spare parts (6.3) .....	21
Duty conditions (1.5).....	4	Specific machine performance (1.8) .....	9
Electrical connections (4.6) .....	15	Starting the pump (5.7).....	18
End of product life (2.5).....	11	Stop/start frequency (5.8.4) .....	19
Examination of parts (6.10) .....	26	Stopping and shutdown (5.9).....	19
Fastener torques (6.6) .....	26	Storage, pump (2.4) .....	11
Faults; causes and remedies (7) .....	28	Storage, spare parts (6.3.2).....	22
Foundation (4.3) .....	13	Supplementary manuals or information sources.....	33
General arrangement drawing (8.5).....	33	Supplementary User Instructions (10.1).....	33
General assembly drawings (see 8) .....	30	Tools required (6.5) .....	22
Grouting (4.4) .....	13	Torques for fasteners (6.6) .....	22
Guarding (5.5) .....	18	Trouble-shooting (see 7) .....	28
Handling (2.2).....	10	Vibration (5.8.3).....	19
Hydraulic, mechanical and electrical duty (5.10).....	20		
Impeller clearance (5.3 and 6.7)			
Inspection (6.2.1 and 6.2.2).....	21		
Installation (4) .....	13		
Lifting (2.3) .....	10		
Location (4.1).....	13		
Lubrication (5.1.1, 5.2 and 6.2.3)			
Lubrication schedule (5.2.5) .....	18		
Maintenance (6).....	20		
Maintenance schedule (6.2).....	21		
Name nomenclature (3.2) .....	11		
Nameplate (1.7.1) .....	9		
Operating limits (3.4.1).....	12		
Ordering spare parts (6.3.1) .....	21		
Part assemblies (4.2) .....	13		
Parts lists (8).....	30		
Performance (3.4).....	12		
Piping (4.5) .....	13		
Pre-commissioning (5.1) .....	16		
Priming and auxiliary supplies (5.6).....	18		
Protection systems (4.7) .....	15		

## 1 INTRODUCTION AND SAFETY

### 1.1 General

 ***These instructions must always be kept close to the product's operating location or directly with the product.***

Flowserve products are designed, developed and manufactured with state-of-the-art technologies in modern facilities. The unit is produced with great care and commitment to continuous quality control, utilising sophisticated quality techniques, and safety requirements.

Flowserve is committed to continuous quality improvement and being at service for any further information about the product in its installation and operation or about its support products, repair and diagnostic services.

These instructions are intended to facilitate familiarization with the product and its permitted use. Operating the product in compliance with these instructions is important to help ensure reliability in service and avoid risks. The instructions may not take into account local regulations; ensure such regulations are observed by all, including those installing the product. Always coordinate repair activity with operations personnel, and follow all plant safety requirements and applicable safety and health laws and regulations.

 ***These instructions must be read prior to installing, operating, using and maintaining the equipment in any region worldwide. The equipment must not be put into service until all the conditions relating to safety, noted in the instructions, have been met. Failure to follow and apply the present user instructions is considered to be misuse. Personal injury, product damage, delay or failure caused by misuse are not covered by the Flowserve warranty.***

### 1.2 CE marking and approvals

It is a legal requirement that machinery and equipment put into service within certain regions of the world shall conform with the applicable CE Marking Directives covering Machinery and, where applicable, Low Voltage Equipment, Electromagnetic Compatibility (EMC), Pressure Equipment Directive (PED) and Equipment for Potentially Explosive Atmospheres (ATEX).

Where applicable, the Directives and any additional Approvals, cover important safety aspects relating to machinery and equipment and the satisfactory provision

of technical documents and safety instructions. Where applicable this document incorporates information relevant to these Directives and Approvals.

To confirm the Approvals applying and if the product is CE marked, check the serial number plate markings and the Certification. (See section 9, *Certification*.)

### 1.3 Disclaimer

***Information in these User Instructions is believed to be complete and reliable. However, in spite of all of the efforts of Flowserve Corporation to provide comprehensive instructions, good engineering and safety practice should always be used.***

Flowserve manufactures products to exacting International Quality Management System Standards as certified and audited by external Quality Assurance organisations. Genuine parts and accessories have been designed, tested and incorporated into the products to help ensure their continued product quality and performance in use. As Flowserve cannot test parts and accessories sourced from other vendors the incorrect incorporation of such parts and accessories may adversely affect the performance and safety features of the products. The failure to properly select, install or use authorised Flowserve parts and accessories is considered to be misuse. Damage or failure caused by misuse is not covered by the Flowserve warranty. In addition, any modification of Flowserve products or removal of original components may impair the safety of these products in their use.

### 1.4 Copyright

All rights reserved. No part of these instructions may be reproduced, stored in a retrieval system or transmitted in any form or by any means without prior permission of Flowserve.

### 1.5 Duty conditions

This product has been selected to meet the specifications of your purchaser order. The acknowledgement of these conditions has been sent separately to the Purchaser. A copy should be kept with these instructions.

 ***The product must not be operated beyond the parameters specified for the application. If there is any doubt as to the suitability of the product for the application intended, contact Flowserve for advice, quoting the serial number.***

If the conditions of service on your purchase order are going to be changed (for example liquid pumped, temperature or duty) it is requested that the user seeks the written agreement of Flowserve before start-up.

## 1.6 Safety

### 1.6.1 Summary of safety markings

These User Instructions contain specific safety markings where non-observance of an instruction would cause hazards. The specific safety markings are:

 **DANGER** This symbol indicates electrical safety instructions where non-compliance will involve a high risk to personal safety and could result in loss of life.

 This symbol indicates safety instructions where non-compliance would affect personal safety and could result in loss of life.

 This symbol indicates “hazardous and toxic fluid” safety instructions where non-compliance would affect personal safety and could result in loss of life.

 This symbol indicates explosive atmosphere zone marking according to ATEX. It is used in safety instructions where non-compliance in the hazardous area would cause the risk of an explosion, and will involve a high risk to personal safety and could result in loss of life.

 **CAUTION** This symbol indicates safety instructions where non-compliance will involve some risk to safe operation and personal safety and would damage the equipment or property.

 This symbol is used in safety instructions to remind not to rub non-metallic surfaces with a dry cloth; ensure the cloth is damp. It is used in safety instructions where non-compliance in the hazardous area would cause the risk of an explosion.

**Note:** This sign is not a safety symbol but indicates an important instruction in the assembly process.

### 1.6.2 Personnel qualification and training

All personnel involved in the operation, installation, inspection and maintenance of the unit must be qualified to carry out the work involved. If the personnel in question do not already possess the necessary knowledge and skill, appropriate training and instruction must be provided. If required the operator may commission the manufacturer/supplier to provide applicable training.

Always coordinate repair activity with operations and health and safety personnel, and follow all plant safety requirements and applicable safety and health laws and regulations.

### 1.6.3 Safety action

***This is a summary of conditions and actions to help prevent injury to personnel and damage to the environment and to equipment. For products used in potentially explosive atmospheres section 1.6.4 also applies.***

 **DANGER** NEVER DO MAINTENANCE WORK WHEN THE UNIT IS CONNECTED TO POWER

 GUARDS MUST NOT BE REMOVED WHILE THE PUMP IS OPERATIONAL

 DRAIN THE PUMP AND ISOLATE PIPEWORK BEFORE DISMANTLING THE PUMP

The appropriate safety precautions should be taken where the pumped liquids are hazardous.

 **FLUORO-ELASTOMERS** (When fitted.) When a pump has experienced temperatures over 250 °C (482 °F), partial decomposition of fluoro-elastomers (example: Viton) will occur. In this condition these are extremely dangerous and skin contact must be avoided.

 **HANDLING COMPONENTS** Many precision parts have sharp corners and the wearing of appropriate safety gloves and equipment is required when handling these components. To lift heavy pieces above 25 kg (55 lb) use a crane appropriate for the mass and in accordance with current local regulations.

 **THERMAL SHOCK** Rapid changes in the temperature of the liquid within the pump can cause thermal shock, which can result in damage or breakage of components and should be avoided.

 **NEVER APPLY HEAT TO REMOVE IMPELLER** Trapped lubricant or vapor could cause an explosion.

 **HOT (and cold) PARTS** If hot or freezing components or auxiliary heating supplies can present a danger to operators and persons entering the immediate area action must be taken to avoid accidental contact. If complete protection is not possible, the machine access must be limited to maintenance staff only, with clear visual warnings and indicators to those entering the immediate area. Note: bearing housings must not be insulated and drive motors and bearings may be hot.

***If the temperature is greater than 80 °C (175 °F) or below -5 °C (23 °F) in a restricted zone, or exceeds local regulations, action as above shall be taken.***



**HAZARDOUS LIQUIDS**

When the pump is handling hazardous liquids care must be taken to avoid exposure to the liquid by appropriate siting of the pump, limiting personnel access and by operator training. If the liquid is flammable and or explosive, strict safety procedures must be applied.



**PREVENT EXCESSIVE EXTERNAL PIPE LOAD**

Do not use pump as a support for piping. Do not mount expansion joints, unless allowed by Flowserve in writing, so that their force, due to internal pressure, acts on the pump flange.



**NEVER RUN THE PUMP DRY**

Liquid level controls in the sump are recommended to avoid the risk of dry running.



**NEVER RUN WITHOUT COLUMN COOLANT TO THE CORRECT LEVEL**

Check the dip stick to ensure the line bearings avoid the risk of their dry running.



**ENSURE CORRECT LUBRICATION**

(See section 5, *Commissioning, start-up, operation and shutdown.*)



**ONLY CHECK DIRECTION OF MOTOR ROTATION WITH COUPLING ELEMENT/ PINS REMOVED**

Starting in reverse direction of rotation will damage the pump.

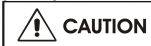

**START THE PUMP WITH OUTLET VALVE PART OPENED**

(Unless otherwise instructed at a specific point in the User Instructions.)

This is recommended to minimize the risk of overloading and damaging the pump or motor at full or zero flow. Pumps may be started with the valve further open only on installations where this situation cannot occur. The pump outlet control valve may need to be adjusted to comply with the duty following the run-up process. (See section 5, *Commissioning start-up, operation and shutdown.*)



**DO NOT RUN THE PUMP AT ABNORMALLY HIGH OR LOW FLOW RATES**

Operating at a flow rate higher than normal or at a flow rate with no back pressure on the pump may overload the motor and cause cavitation. Low flow rates may cause a reduction in pump/bearing life, overheating of the pump, instability and cavitation/vibration.

**1.6.4 Products used in potentially explosive atmospheres**



Measures are required to:

- Avoid excess temperature
- Prevent build up of explosive mixtures
- Prevent the generation of sparks
- Prevent leakages
- Maintain the pump to avoid hazard

The following instructions for pumps and pump units when installed in potentially explosive atmospheres must be followed to help ensure explosion protection. For ATEX, both electrical and non-electrical equipment must meet the requirements of European Directive 2014/34/EU (previously 94/9/EC which remains valid until 20 April 2016 during the transition). Always observe the regional legal Ex requirements e.g. Ex electrical items outside the EU may be required certified to other than ATEX e.g. IECEx, UL.

**1.6.4.1 Scope of compliance**



Use equipment only in the zone for which it is appropriate. Always check that the driver, drive coupling assembly, seal and pump equipment are suitably rated and/or certified for the classification of the specific atmosphere in which they are to be installed.

Where Flowserve has supplied only the bare shaft pump, the Ex rating applies only to the pump. The party responsible for assembling the ATEX pump set shall select the coupling, driver and any additional equipment, with the necessary CE Certificate/ Declaration of Conformity establishing it is suitable for the area in which it is to be installed.

The motor, coupling, pump thrust bearing and seal can be made compliant with ATEX Directive 2014/34/EU (previously 94/9/EC which remains valid until 20 April 2016 during the transition) for Equipment Categories 2 and 3 as required by the duty conditions.

See the pump nameplate and Declaration of Conformity for the pump classification. The pump column below sole plate will be to the same category (See section 1.6.4.2.)

Users must pay particular attention to pump operation and maintenance instructions because of the hazard of the explosive atmosphere.

The output from a variable frequency drive (VFD) can cause additional heating effects in the motor and so, for pump sets with a VFD, the ATEX Certification for the motor must state that it covers the situation where electrical supply is from the VFD. This particular requirement still applies even if the VFD is in a safe area.

**1.6.4.2 Marking**

An example of ATEX equipment marking is shown below. The actual classification of the pump will be engraved on the nameplate

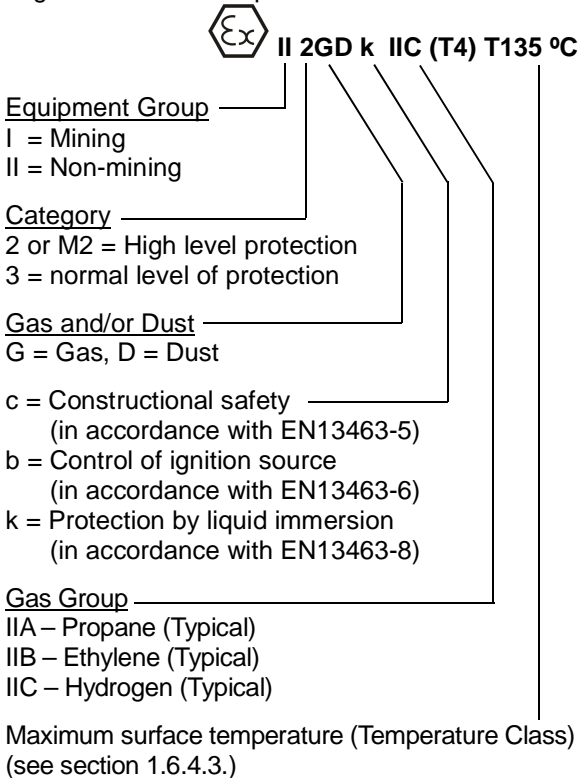

**1.6.4.3 Avoiding excessive surface temperatures**

**Ex** ENSURE THE EQUIPMENT TEMPERATURE CLASS IS SUITABLE FOR THE HAZARD ZONE

Pumps have a temperature class as stated in the ATEX Ex rating on the nameplate.

The surface temperature on the pump is influenced by the temperature of the liquid handled. The maximum permissible liquid temperature depends on the ATEX temperature class and must not exceed the values in the table that follows:

Temperature class to EN 13463-1	Maximum surface temperature permitted	Temperature limit of liquid handled
T6	85 °C (185 °F)	65 °C (149 °F) *
T5	100 °C (212 °F)	80 °C (176 °F) *
T4	135 °C (275 °F)	115 °C (239 °F) *
T3	200 °C (392 °F)	180 °C (356 °F) *
T2	300 °C (572 °F)	275 °C (527 °F) *
T1	450 °C (842 °F)	400 °C (752 °F) *

\* The table only takes the ATEX temperature class into consideration. Pump design or material, as well as component design or material, may further limit the liquid maximum working temperature

The temperature rise at the seals and bearings and due to the minimum permitted flow rate is taken into account in the temperatures stated.

**The operator is responsible to ensure the specified maximum liquid temperature is not exceeded.**

Temperature classification “Tx” is used when the liquid temperature varies and when the pump is required to be used in differently classified potentially explosive atmospheres. In this case the user is responsible for ensuring that the pump surface temperature does not exceed that permitted in its actual installed location.

Do not attempt to check the direction of rotation with the coupling element/pins fitted due to the risk of severe contact between rotating and stationary components.

Where there is any risk of the pump being run against a closed valve generating high liquid and casing external surface temperatures fit an external surface temperature protection device.

Avoid mechanical, hydraulic or electrical overload by using motor overload trips, a temperature or power monitor and make routine vibration monitoring checks.

In dirty or dusty environments, make regular checks and remove dirt from areas around close clearances, bearing housings and motors.

**The equipment utilises seals and bearing surfaces that may be polymer based which could be corroded if they are in contact with unsuitable liquids or gases. These surfaces are important for the operation of the pump. Contact Flowserve if you are uncertain about the performance of these materials with respect to aggressive substances that may be present in the hazardous area.**

The pump casing must be flooded with liquid to the minimum level on the dimensional general arrangement (GA) drawing, at any time that the pump is operated. Monitoring of the level with a pump cut out on low level is required.

Where there is the potential hazard of a loss of a dual seal barrier fluid the barrier fluid system must be monitored.

Where there is a risk that the external flush to a dual seal, for example by freezing, blocking by debris or loss of supply pressure, then the flow must be monitored.

Visual indicators are suitable when equipment is regularly inspected, but sensors connected to the pump control system must be used if the pump runs remotely.

For Category 2 equipment the monitoring must create an alarm to the plant operator or shut down the pump.

The monitoring equipment must be suitable for the hazardous area.

See also sections 5.8.2 to 5.8.6.

**1.6.4.4 Preventing the build-up of explosive mixtures**



ENSURE THE PUMP IS PROPERLY FILLED AND VENTED AND DOES NOT RUN DRY

Ensure the pump and relevant suction and discharge pipeline system is totally filled with liquid at all times during the pump operation, so that an explosive atmosphere is prevented. In addition it is essential to make sure that seal chambers, auxiliary shaft seal systems and any heating and cooling systems are properly filled.

If the operation of the system cannot avoid this condition, fit an appropriate dry run protection device (for example liquid detection or a power monitor).

To avoid potential hazards from fugitive emissions of vapour or gas to atmosphere the surrounding area must be well ventilated.

**1.6.4.5 Preventing sparks**



To prevent a potential hazard from mechanical contact, the coupling guard must be non-sparking and anti-static for Category 2.

To avoid the potential hazard from random induced current generating a spark, the sole plate must be properly grounded.



Avoid electrostatic charge: do not rub non-metallic surfaces with a dry cloth; ensure cloth is damp.

For ATEX the coupling must be selected to comply with the requirements of European Directive 2014/34/EU (previously 94/9/EC which remains valid until 20 April 2016 during the transition). Correct coupling alignment must be maintained.

**1.6.4.6 Preventing leakage**



The pump must only be used to handle liquids for which it has been approved to have the correct corrosion resistance.

Avoid entrapment of liquid in the pump and associated piping due to closing of suction and discharge valves, which could cause dangerous excessive pressures to occur if there is heat input to the liquid. This can occur if the pump is stationary or running.

Bursting of liquid containing parts due to freezing must be avoided by draining or protecting the pump and ancillary systems.

If leakage of liquid to atmosphere can result in a hazard, install a liquid detection device.

**1.6.4.7 Maintenance to avoid the hazard**



CORRECT MAINTENANCE IS REQUIRED TO AVOID POTENTIAL HAZARDS WHICH GIVE A RISK OF EXPLOSION

***The responsibility for compliance with maintenance instructions is with the plant operator.***

To avoid potential explosion hazards during maintenance, the tools, cleaning and painting materials used must not give rise to sparking or adversely affect the ambient conditions. Where there is a risk from such tools or materials, maintenance must be conducted in a safe area.

It is recommended that a maintenance plan and schedule is adopted. (See section 6, *Maintenance*.)



## 1.7 Nameplate and safety labels

### 1.7.1 Nameplate

For details of nameplate, see the *Declaration of Conformity*.

### 1.7.2 Safety labels

		<b>WARNING</b>	J218JZ250
<b>ESSENTIAL PROCEDURES BEFORE STARTING:</b>			
<b>INSTALL AND OPERATE EQUIPMENT IN ACCORDANCE WITH THE INSTRUCTION MANUAL SUPPLIED SEPARATELY.</b> <b>ENSURE GUARDS ARE SECURELY IN PLACE.</b> <b>ENSURE CORRECT DIRECTION OF ROTATION.</b>	<b>ENSURE ALL EXTERNAL CONNECTIONS TO THE PUMP / SHAFT SEALING AND DRIVER ARE CONNECTED AND OPERATIONAL.</b> <b>FULLY PRIME UNIT AND SYSTEM. DO NOT RUN UNIT DRY.</b>	<b>FAILURE TO FOLLOW THESE PROCEDURES MAY RESULT IN PERSONAL INJURY AND / OR EQUIPMENT DAMAGE</b>	
J218JZ265			
<b>ENSURE CORRECT DRIVER DIRECTION OF ROTATION WITH COUPLING ELEMENT / PINS REMOVED; OTHERWISE SERIOUS DAMAGE MAY RESULT.</b> <b>VERIFIER LE SENS CORRECT DE ROTATION DU MOTEUR. POMPE DESACCOUPLEE / ENTRETOISE DEMONTEE. NE PAS SUIVRE CETTE RECOMMANDATION PEUT CONDUIRE A DE GRAVES DOMMAGES POUR LA POMPE</b>	<b>KONTROLLE VORGESCHRIEBENER DREHRICHTUNG ! HIERZU KUPPLUNGZWISCHENSTÜCK / KUPPLUNGSBOLZEN ENTFERNEN. ANDERENFALLS ERNSTHAFTE SCHÄDEN !</b> <b>ZORG VOOR JUISTE ROTATIERICHTING VAN DRIJFAS WAARBIJ DE KOPPELEMENTEN / PENNEN VERWIJDERD ZIJN; VERZIJM KAN ERNSTIGE SCHADE TOT GEVOLG HEBBEN.</b>		

## 1.8 Specific machine performance

For performance parameters see section 1.5, *Duty conditions*. Where performance data has been supplied separately to the purchaser these should be obtained and retained with these User Instructions if required.

## 1.9 Noise level

Attention must be given to the exposure of personnel to the noise, and local legislation will define when guidance to personnel on noise limitation is required, and when noise exposure reduction is mandatory. This is typically 80 to 85 dBA.

The usual approach is to control the exposure time to the noise or to enclose the machine to reduce emitted sound. You may have already specified a limiting noise level when the equipment was ordered, however if no noise requirements were defined, then attention is drawn to the following table to give an indication of equipment noise level so that you can take the appropriate action in your plant.

Pump noise level is dependent on a number of operational factors, flow rate, pipework design and acoustic characteristics of the building, and so the values given are subject to a 3 dBA tolerance and cannot be guaranteed.

Similarly the motor noise assumed in the “pump and motor” noise is that typically expected from standard and high efficiency motors when on load directly driving the pump. Note that a motor driven by an inverter may show an increased noise at some speeds.

If a pump unit only has been purchased for fitting with your own driver then the “pump only” noise levels in the table should be combined with the level for the driver obtained from the supplier. Consult Flowserve or a noise specialist if assistance is required in combining the values.

It is recommended that where exposure approaches the prescribed limit, then site noise measurements should be made.

The values are in sound pressure level  $L_{pA}$  at 1 m (3.3 ft) from the machine, for “free field conditions over a reflecting plane”.

For estimating sound power level  $L_{WA}$  (re 1 pW) then add 14 dBA to the sound pressure value.

The values in below table are valid for preferred range of pump operation, 80% to 110% of B.E.P.

Motor size and speed kW (hp)	Typical sound pressure level L <sub>pA</sub> at 1 m reference 20 μPa, dBA							
	3 550 r/min		2 900 r/min		1 750 r/min		1 450 r/min	
	Pump only	Pump and motor	Pump only	Pump and motor	Pump only	Pump and motor	Pump only	Pump and motor
<0.55 (<0.75)	58	65	50	58	50	52	50	52
0.75 (1)	60	65	52	59	51	54	51	54
1.1 (1.5)	62	67	54	60	55	57	53	56
1.5 (2)	63	66	55	63	56	59	54	58
2.2 (3)	64	69	57	65	58	62	56	60
3 (4)	63	71	58	68	59	64	57	62
4 (5)	64	72	60	69	61	65	59	63
5.5 (7.5)	66	73	62	71	63	67	61	65
7.5 (10)	67	73	63	71	64	69	62	67
11 (15)	69	76	65	73	66	71	64	69
15 (20)	71	77	67	74	68	72	66	70
18.5 (25)	72	78	68	75	69	70	67	70
22 (30)	73	78	69	76	70	71	68	71
30 (40)	75	79	71	77	72	72	70	72
37 (50)	76	80	72	78	73	73	71	73
45 (60)	77	81	73	79	74	74	72	74
55 (75)	78	81	74	79	75	75	73	75
75 (100)	80	83	76	81	77	76	75	76
90 (120)	81	84	77	81	78	77	76	77
110 (150)	82	85	78	82	79	78	77	78
150 (200)	84	87	80	84	81	79	79	79
200 (270)	①	①	①	①	81	81	79	79
300 (400)			-		83	86	81	82

① The noise level of machines in this range will most likely be of values which require noise exposure control, but typical values are inappropriate. **Note:** for 1 180 and 960 r/min reduce 1 450 r/min values by 2 dBA. For 880 and 720 r/min reduce 1 450 r/min values by 3 dBA.

## 2 TRANSPORT AND STORAGE

### 2.1 Consignment receipt and unpacking

Immediately after receipt of the equipment it must be checked against the delivery/shipping documents for its completeness and that there has been no damage in transportation. Any shortage and/or damage must be reported immediately to Flowserve and must be received in writing within one month of receipt of the equipment. Later claims cannot be accepted.

Check any crate, boxes or wrappings for any accessories or spare parts that may be packed separately with the equipment or attached to side walls of the box or equipment.

Each product has a unique serial number. Check that this number corresponds with that advised and always quote this number in correspondence as well as when ordering spare parts or further accessories.

### 2.2 Handling

Boxes, crates, pallets or cartons may be unloaded using fork lift vehicles or slings dependent on their size and construction.

### 2.3 Lifting

 A crane must be used for all pump sets in excess of 25 kg (55 lb). Fully trained personnel must carry out lifting, in accordance with local regulations.

Pumps with drivers over approximately 7.5 kW, are supplied with the pump packed as a separate item from the driver. For improved stability unbolt the driver and lift the driver and pump separately. These and should be lifted separately into their installed position, using lifting points on the pump soleplate, and on the motor.

 **CAUTION** Pumps and motors often have integral lifting lugs or eye bolts. These are intended for use in only lifting the individual piece of equipment. Before lifting the driver alone, refer to the manufacturer's instructions.

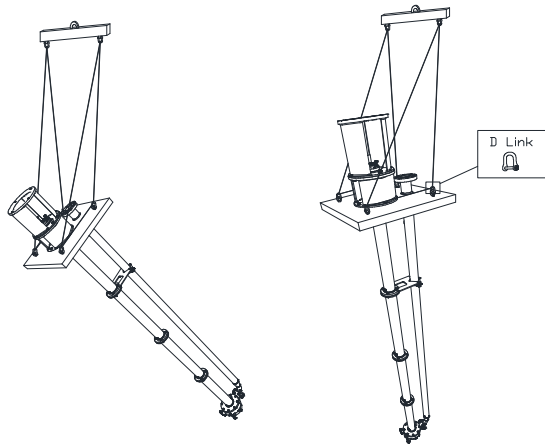

Drawing taken from B736/623

**CAUTION** When lifting pumps with drivers fitted, the resulting center of gravity may be above the lifting points, and the method of slinging must prevent the machine tipping during the lift. Slings, ropes and other lifting gear must be positioned where they cannot slip and where a balanced lift is obtained.

Most units are supplied with four lifting points on the pump sole plate [6140]. Attach D-links onto all four lifting points. Use a spreader beam attached to an overhead crane and fit 2 D-links. Ensure the sling is not in contact with the pin of any of the D-links. Lift the pump up to the vertical, as shown in the above figures, using the D-links on the sole plate as shown.

**CAUTION** To avoid distortion, the pump unit should be lifted as shown.

**2.4 Storage**

**CAUTION** Store the pump in a clean, dry location away from vibration. Leave piping connection covers in place to keep dirt and other foreign material out of pump casing. Turn pump at intervals to prevent brinelling of the bearings and the seal faces, if fitted, from sticking.

The pump may be stored as above for up to six months. Consult Flowserve for preservative actions when a longer storage period is needed.

**2.5 Recycling and end of product life**

At the end of the service life of the product or its parts, the relevant materials and parts should be recycled or disposed of using an environmentally acceptable method and local requirements. If the product contains substances that are harmful to the environment, these should be removed and disposed of in accordance with current regulations. This also includes the liquids and or gases that may be used in the "seal system" or other utilities.

**Warning:** Make sure that hazardous substances are disposed of safely and that the correct personal protective equipment is used. The safety specifications must be in accordance with the current regulations at all times.

**3 DESCRIPTION**

**3.1 Configurations**

The pump is a modular designed centrifugal pump that can be built to achieve almost all chemical liquid pumping requirements. (See 3.2 and 3.3 below.)

**3.2 Name nomenclature**

The pump size will be engraved on the nameplate typically as below:

**1E50-32-125A-OP**

ISO bearing housing \_\_\_\_\_  
size (1, 2, 3 or 4)

Model series:  
E = enclosed lineshaft column design

Casing nominal suction size in mm \_\_\_\_\_

Casing discharge size in mm \_\_\_\_\_

Nominal ISO maximum impeller diameter in mm \_\_\_\_\_

A = Extended flow hydraulics \_\_\_\_\_  
B = Standard hydraulics

Impeller design - after separator: \_\_\_\_\_  
RV = reverse vane or OP = open impeller

**2E3x2-10R-RV**

ASME impeller drive \_\_\_\_\_  
size (1, 2, 3 or 4)

Model series:  
E = enclosed lineshaft column design

Casing nominal suction size in inches \_\_\_\_\_

Casing discharge size in inches \_\_\_\_\_

Nominal maximum impeller diameter in inches \_\_\_\_\_

R = low shear impeller \_\_\_\_\_

Impeller design - after separator: \_\_\_\_\_  
RV = reverse vane or OP = open impeller  
(High Chrome Iron and Tungsten carbide wet ends only available with OP impeller.)

### 3.3 Design of major parts

#### 3.3.1 Pump casing

The pump casing is designed for operation when submerged in the sump liquid.

**Note:** High chrome iron casing has a much reduced pressure rating of 12.6 bar (183 psi).

##### 3.3.1.1 Agitation system

This option is on high chrome iron/tungsten carbide coated casings.

#### 3.3.2 Impeller

Generally an open impeller (OP impeller) is fitted. On the low shear impeller this is recessed within the back of the casing and the impeller setting is to the rear back-vanes. A reverse vane (RV impeller) is an option.

#### 3.3.3 Shaft

The shaft has a keyed drive coupling. It is supported by rolling bearing(s) above the sole plate and journal line bearing(s) below. Rigid inter-shaft couplings and or a key drive impeller are available options that can assist pump maintenance.

#### 3.3.4 Bearing housing

The bearing housing enables adjustment of impeller face clearance on the open impeller via the bearing carrier jacking screws.

#### 3.3.5 Pump bearings and lubrication

The pump is fitted with a thrust type ball bearing that may be configured differently dependent on use.

The pump thrust type ball bearing is grease lubricated.

The plain line bearings require the column coolant fill.

#### 3.3.6 Driver

The pump is normally driven by a flange mounted electric motor. An air or hydraulic motor may be utilized.

The position of the terminal box can be changed by rotating the complete motor. To do this, remove the fasteners from the motor flange, rotate the motor and re-fit the fasteners.

#### 3.3.7 Accessories

Accessories may be fitted when specified by the customer.

### 3.4 Performance and operating limits

This product has been selected to meet the specifications of the purchase order. See section 1.5.

The following data is included as additional information to help with your installation. It is typical, and factors such as temperature, materials, and seal type may influence this data. If required, a definitive statement for your particular application can be obtained from Flowserve.

#### 3.4.1 Operating limits

Maximum pump ambient temperature: +55 °C (131 °F) where driver, flexible coupling and thrust bearing is also rated for this ambient. (Check the nameplate.)

Maximum pump speed: refer to the nameplate

#### 3.4.2 Energy efficiency operation of pumps

The pump supplied will have been selected from Flowserve's extensive product line to have optimum efficiency for the application. If supplied with an electric motor then the motor will meet or exceed current legislation for motor efficiency. However it is the way the pump is operated which has the greatest impact on the amount and cost of energy used during the operating life of the pump. The following are key points in achieving minimum operating cost for the equipment:

- Design the pipe system for minimum friction losses
- Ensure that the control system switches off the pump when not required
- In a multi-pump system run the minimum number of pumps
- Try to avoid systems which by-pass excess flow
- As far as possible avoid controlling pump flow by throttle valves
- When commissioned, check that the pump operates at the duty specified to Flowserve
- If the pump head and flow exceed that required, trim the pump impeller diameter
- Ensure that the pump is operating with sufficient NPSH available
- Use variable speed drives for systems that require variable flow. A VFD for an induction motor is a particularly effective way of achieving speed variation and energy/cost reduction
- Notes for VFD usage:
  - make sure that the motor is compatible with VFD
  - Do not over-speed the pump without checking the power capability with Flowserve
  - On systems with high static head, speed reduction is limited. Avoid running the pump at a speed which gives low or zero flow
  - Do not run a low speed and flow rate that lets solids settle out of suspension in the pipework

- Do not use a VFD for a fixed flow requirement; it will introduce power losses
- Select high efficiency motors
- If replacing a standard motor with a high efficiency motor it will run faster and the pump could take more power. Reduce the impeller diameter to achieve energy reduction
- If the pump system pipework or equipment is changed or process duty is changed, check that the pump is still correctly sized
- Periodically check that the pipe system has not become corroded or blocked
- Periodically check that the pump is operating at the flow, head and power expected and that the efficiency has not reduced with erosion or corrosion damage

## 4 INSTALLATION



Equipment operated in hazardous locations must comply with the relevant explosion protection regulations. See section 1.6.4, *Products used in potentially explosive atmospheres*.

### 4.1 Location

The pump should be located to allow room for access, ventilation, maintenance and inspection with ample headroom for lifting and should be as close as practicable to the supply of liquid to be pumped. (Refer to the general arrangement drawing for the pump set.)

### 4.2 Part assemblies

On pump sets the coupling elements are supplied loose. It is the responsibility of the installer to ensure that the pump set is finally lined up and checked as detailed in section 4.5.5, *Final checks*.

### 4.3 Foundation



There are many methods of installing pump units to their foundations. The correct method depends on the size of the pump unit, its location and noise and vibration limitations. Non-compliance with the provision of correct foundation and installation may lead to failure of the pump and, as such, would be outside the terms of the warranty. The pump mounting should have concrete or metal to support it around its edges.

#### 4.3.1 Levelling

The sole plate must be level so that the pump column hangs vertically; confirmed by inspection. With the motor removed check the top face of the machined motor pedestal [3160] is set level to 0.05 mm (0.002 in.) or 0.2 mm/m (0.0025 in./ft) maximum. The optional base plate should be levelled and grouted first.

Larger size motors are shipped unfitted. The motor will need to be fitted after completion of the pump foundation installation. Turn shaft clockwise by hand to ensure it is free to turn.

#### 4.3.2 Packing pieces

Where the sole plate and its counter-face do not each have a machined face, packing pieces (metallic shims) will need to be placed evenly adjacent to the foundation (holding down) bolts to avoid “soft-foot” distortion. Turn shaft clockwise by hand to ensure it is free to turn. Soft-foot distortion may significantly increase vibration and damage equipment by causing distortion and should normally be inspected. If high vibration occurs when pump is run (see section 5, *Commissioning, start-up, operation and shutdown*) place a vibration meter at the side of the motor as soft-foot is most effectively reduced when the vibration is reduced to a minimum.

Overall vibration measurement can be used - it is not necessary to use a vibration spectrum to pick up soft-foot which occurs at 1x running speed and should be the first issue to check.

To adjust for soft-foot use a dial gauge on the sole plate top face near to the holding down bolt, zero it, record the soft-foot spring in the sole plate and undo one holding down bolt at a time.

Soft-foot is removed by inserting packing pieces (metallic shims) equal to or slightly less than the soft-foot spring amount recorded at the individual holding down point locations. Re-torque the holding down bolt. Continue this procedure for each holding down bolt position in turn, one at a time. The thickness of packing pieces (metallic shims) adjacent to an individual holding down bolt should not exceed 3 mm (0.12 in.); i.e. soft-foot spring is not to exceed 3 mm (0.12 in.) at any individual location.

### 4.4 Grouting

Where applicable, grout in the foundation bolts.

Grouting provides solid contact between the pump unit and foundation, prevents lateral movement of vibrating equipment and dampens resonant vibrations.

### 4.5 Piping



Protective covers are fitted to the pipe connections to prevent foreign bodies entering during transportation and installation. Ensure that these covers are removed from the pump before connecting any pipes.



If sludge and debris can build up in the sump it is recommended to use a strainer with a maximum opening size of 6 mm (0.024 in.) and a free surface area greater than three times the pump suction area.

Maximum forces and moments allowed on the pump flanges vary with the pump size and type. To minimize these forces and moments that may, if excessive, cause misalignment, hot bearings, worn couplings, vibration and the possible failure of the pump casing, the following points should be strictly followed:

- Prevent excessive external pipe load
- Never draw piping into place by applying force to pump flange connections
- Do not mount expansion joints so that their force, due to internal pressure, acts on the pump flange

**4.5.1 Discharge pipework**

In order to minimize friction losses and hydraulic noise in the pipework it is good practice to choose pipework that is one or two sizes larger than the pump discharge. Typically main pipework velocities should not exceed 3 m/s (9 ft/sec) on the discharge.



Never use the pump as a support for piping.



Ensure piping and fittings are flushed before use.



Ensure piping for hazardous liquids is arranged to allow pump flushing before removal of the pump.

**4.5.2 Discharge piping**

A non-return valve should be located in the discharge pipework to protect the pump from excessive back pressure and hence reverse rotation when the unit is stopped.

Fitting an isolation valve will allow easier maintenance.

**4.5.3 Maximum forces and moments allowed on the main sole plate discharge flange**

The table below uses the sign convention shown for the pump sole plate discharge flange maximum forces and moments. These are valid for a pump end up to 100 °C (212 °F) and the sole plate on a rigid foundation.

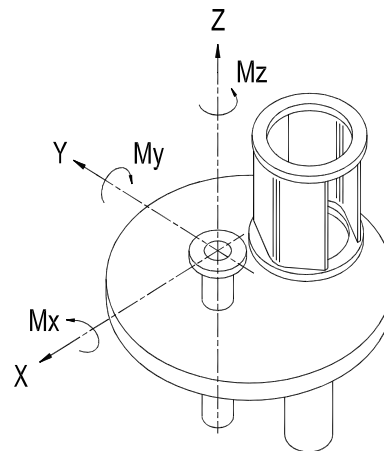

Discharge flange size mm (in.)	Maximum forces (F) in kN (lbf) and moments (M) in Nm (lbf•ft)							
	Fx	Fy	Fz	Fr	Mx	My	Mz	Mr
40 (1.5)	0.71 (160)	0.58 (130)	0.89 (200)	1.28 (290)	0.46 (340)	0.23 (170)	0.35 (260)	0.62 (460)
50 (2.0)	0.71 (160)	0.58 (130)	0.89 (200)	1.28 (290)	0.46 (340)	0.23 (170)	0.35 (260)	0.62 (460)
80 (3.0)	1.07 (240)	0.89 (200)	1.33 (300)	1.93 (430)	0.95 (700)	0.47 (350)	0.72 (530)	1.28 (950)
100 (4.0)	1.42 (320)	1.16 (260)	1.78 (400)	2.56 (570)	1.33 (980)	0.68 (500)	1.00 (740)	1.80 (1 330)
125 (5.0)	1.95 (440)	1.58 (355)	2.45 (550)	3.50 (790)	1.93 (1 420)	0.98 (720)	1.36 (1 000)	2.56 (1 880)
150 (6.0)	2.49 (560)	2.05 (460)	3.11 (700)	4.48 (1 010)	2.30 (1 700)	1.18 (870)	1.76 (1 300)	3.13 (2 310)

**4.5.4 Auxiliary piping**

**4.5.4.1 Pumps fitted with mechanical seals**

Double seals require a barrier liquid between the seals, compatible with the pumped liquid.

Back-to-back double seals require that the barrier liquid should be at a minimum pressure of 1 bar (15 psi) above the maximum pressure on the pump side of the inner seal. The barrier liquid pressure must not exceed limitations of the seal on the coolant. For toxic service the barrier liquid supply and discharge must be handled safely and in line with local legislation.

Special seals may require modification to auxiliary piping described above. Seal on pumps in potentially explosive atmospheres shall comply with section 1.6.4.3. Consult Flowserve if unsure of correct method or arrangement.

**4.5.5 Final checks**

Check the tightness of all bolts in the suction and discharge pipework. Check also the tightness of all foundation bolts.

After connecting piping to the pump, rotate the shaft several times by hand to ensure there is no binding and all parts are free.

Recheck the flexible element coupling is aligned with the permitted limits.

**Note:** Where there is the option of an additional

licator  
s for

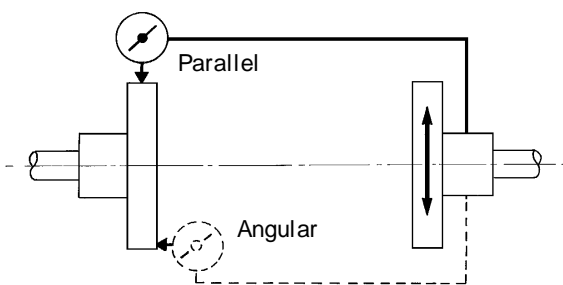

Permissible misalignment limits at working temperature:

- **Parallel alignment**
  - 0.25 mm (0.010 in.) TIR maximum
- **Angular alignment**
  - 0.3 mm (0.012 in.) TIR maximum for couplings not exceeding 100 mm (4 in.) flange diameter
  - 0.5 mm (0.020 in.) TIR maximum for couplings over 100 mm (4 in.) diameter
- Use the lower of the above values and values indicated in the coupling manual

When checking parallel alignment, the total indicator read-out (TIR) shown is twice the value of the actual shaft displacement.

If alignment needs to be adjusted, a small amount of adjustment of the motor is available within the motor spigot but alignment is generally achieved automatically on assembly. Larger motors always require re-adjustment.

If it is not possible to achieve the alignment accuracy defined, it may be an indication that the pump has not been installed or handled correctly.

**4.6 Electrical connections**

**DANGER** Electrical connections must be made by a qualified Electrician in accordance with relevant local national and international regulations.

**Ex** It is important to be aware of the EUROPEAN DIRECTIVE on potentially explosive areas where compliance with IEC60079-14 is an additional requirement for making electrical connections.

**!** It is important to be aware of the EUROPEAN DIRECTIVE on electromagnetic compatibility when wiring up and installing equipment on site. Attention must be paid to ensure that the techniques used during wiring/installation do not increase electromagnetic emissions or decrease the electromagnetic immunity of the equipment, wiring or any connected devices. If in any doubt, contact Flowserve for advice.

**DANGER** The motor must be wired up in accordance with the motor manufacturer's instructions (normally supplied within the terminal box). Any temperature, earth leakage, current or other appropriate protective devices must be correctly installed and monitored. The identification nameplate should be checked to ensure the power supply is appropriate.

**!** A device to provide emergency stopping must be fitted. If not supplied pre-wired to the pump unit, the controller/starter electrical details will also be supplied within the controller/starter. For electrical details on pump sets with controllers see the separate wiring diagram.

**CAUTION** See section 5.4, *Direction of rotation*, before connecting the motor to the electrical supply.

**4.7 Protection systems**

**Ex** The following protection systems are recommended but are mandatory if the pump is installed in a potentially explosive area or is handling a hazardous liquid. If in any doubt consult Flowserve.

If there is any possibility of the system allowing the pump to run against a closed valve or below minimum continuous safe flow a protection device must be installed to ensure the temperature of the liquid does not rise to an unsafe level.

If leakage of product from the pump or its associated sealing system can cause a hazard it is recommended that an appropriate leakage detection system is installed.

To prevent thrust bearing damage becoming a safety hazard it is recommended that monitoring of vibration is carried out.

Where there is the potential hazard of a loss of a seal barrier fluid the barrier fluid system must be monitored.

Where there is a risk that the external flush to a seal or bearing could fail, for example by freezing, blocking by debris or loss of supply pressure, then the flow must be monitored.

Where there is product flush via filters then flow must be monitored.

Visual indicators are suitable when equipment is regularly inspected, but sensors connected to the pump control system must be used if the pump runs remotely.

For Category 2 equipment the monitoring must create an alarm to the plant operator or shut down the pump.

The monitoring equipment must be suitable for the hazardous area.

See also sections 5.8.2 to 5.8.7.

The protection sensors will generally be fitted by Flowserve, but the connection to the pump control system will often be by the installer of the pump. Installers must ensure that the instructions of the sensor manufacturer are followed, that any additional components are suitable for the zone in which they are to be installed, and that their trip levels are set and checked during commissioning. The protective systems must also be periodically checked in accordance with the sensor manufacturer's instructions or with local site standards.

When clean process liquids are used to flush bearings the user must periodically check that there is no contamination entering the sump.

## 5 COMMISSIONING, START-UP, OPERATION AND SHUTDOWN

 ***These operations must be carried out by fully qualified personnel.***

**Note:** Contact the factory for recommendations for operation with pumpage of any fluid other than what the pump was specifically designed for.

### 5.1 Pre-commissioning procedure

Prior to starting the pump it is essential that the following checks be made.

- Motor properly secured to the motor stool
- All fasteners tight and to the correct torque
- Coupling guard is in place
- Rotation check, see section 5.4.
- Impeller clearance setting
- Shaft seal properly installed
- Column coolant
- Bearing lubrication
- Pump instrumentation is operational
- Rotation of shaft is free when pump mechanically and electrically isolated

#### 5.1.1 Rolling element bearing lubrication

Determine the mode of lubrication of the pump set, e.g. pumps with grease lubricated antifriction bearings are normally supplied fitted with grease nipples and with pre-greased bearings.

Grease lubricated electric motor bearings are generally pre-greased. Refer to the motor User Instructions for information on the motor lubrication schedule.

Where the ambient is very low special lubricants are required. If in doubt consult Flowserve for recommendations of oil and grease types at these lower temperatures. Where low ambient grease for less than -20 to +100 °C (-4 to +212 °F) has been specially fitted this is Shell Aeroshell 22.

### 5.2 Pump lubricants and coolants

#### 5.2.1 Column coolant

 To facilitate the transport and handling of the pump, it is delivered without coolant in the enclosing columns. It is essential that before start-up that it is filled with the recommended coolant to avoid running dry.

The filler with dip stick is on the soleplate near the motor support as shown below, ensure to fill the minimum/maximum check level and to top up as necessary.

 Do not exceed the maximum level.



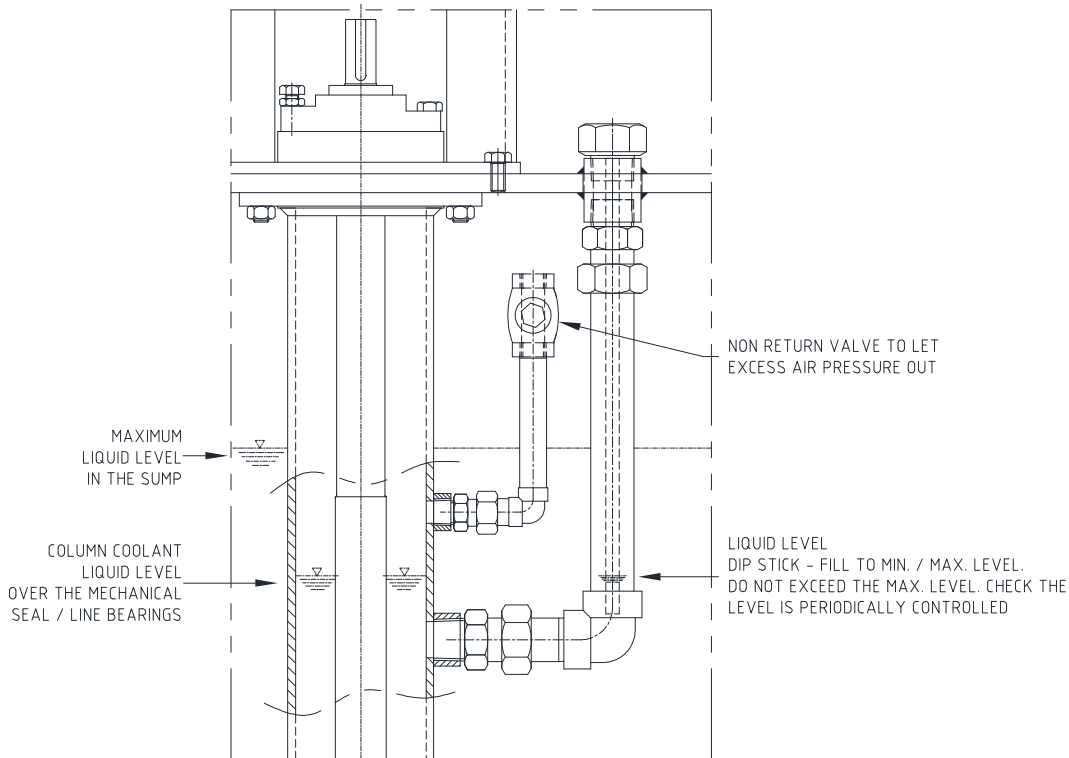

Drawing taken from B736/625

Use water with anti-freeze, mixing a proportion to be 2:1 minimum which protects for temperatures down to approximately -15 °C (5 °F). The following table has recommended commercial qualities having corrosion inhibitors and a defoaming agent (commercially readily available - the same as used in most car radiators). Higher corrosion protection is obtained with a proportion mix of 1:1.

Anti-freeze grade	Type base
Dow coolant D824 13F	Ethylene glycol
BP anti-frost	Ethylene glycol
Dow frost 1.2.3	Propylene glycol
BP anti-frost	Propylene glycol

These are claimed by their manufacturers to be biologically decomposable.

### 5.2.2 Rolling element bearing sizes and grease/oil capacities

Shaft size	1	2
Medium duty thrust bearing duplex back-to-back AC	3306C3	3309C3
Heavy duty thrust bearing duplex back-to-back AC	7306 pair	7309 pair

Grease quantities – g (oz)	14 (0.5)	25 (0.9)
----------------------------	----------	----------

**Note:** The bearing sizes do not constitute a purchasing specification.

### 5.2.3 Recommended rolling element bearing grease lubricants

Grease	NLGI 2 *	NLGI 3
Temp. range	-20 to +100 °C (-4 to +212 °F)	-20 to +100 °C (-4 to +212 °F)
Designation acc. to DIN	KP2K-25	KP3K-20
<b>BP</b>	Energrease LS-EP2	Energrease LS-EP3
<b>Elf</b>	Multis EP2	Multis EP3
<b>Fuchs</b>	RENOLIT EP2	RENOLIT EP3
<b>Esso</b>	Beacon EP2	Beacon EP3
<b>Mobil</b>	Mobilux EP2	Mobilux EP3 **
<b>Q8</b>	Rembrandt EP2	Rembrandt EP3
<b>Shell</b>	Alvania EP2	Alvania EP2
<b>Texaco</b>	Multifak EP2	Multifak EP3
<b>SKF</b>	LGE2	

\* NLGI 2 is an alternative grease and is not to be mixed with other grades.

\*\* Standard pre-packed grease for fitted antifriction bearings.

#### 5.2.3.1 Food grade grease (when applicable)

NSF H1 Klubersynth UH1 64-62 is the food grade grease option and it is NLGI grade 2.

### 5.2.4 Recommended fill quantities

Refer to section 5.2.2, *Rolling element bearing sizes and grease capacities.*

**5.2.5**  **Lubrication schedule**

**5.2.5.1 Grease lubricated rolling element bearings**

When grease nipples are fitted, one charge between grease changes is advisable for most operating conditions; i.e. 2 000 hours interval. Normal intervals between grease changes are 4 000 hours or at least every 6 months. For food grade grease the grease change and re-lubrication intervals are half that of the conventional greases.

The characteristics of the installation and severity of service will determine the frequency of lubrication. Lubricant and bearing temperature analysis can be useful in optimizing lubricant change intervals.

The bearing temperature may be allowed to rise to 55 °C (99 °F) above ambient, but should not exceed 95 °C (204 °F). For most operating conditions, a quality grease having a lithium soap base and NLGI consistency of No 2 or No 3 is recommended. The drop point should exceed 175 °C (350 °F).



 T5 and T6 temperature classes have more restrictive temperature control limits, see 5.8.3.

 Never mix greases containing different bases, thickeners or additives.



**5.3 Open impeller clearance**

The impeller clearance is set in the factory. This may require adjustment because of increase in liquid temperature. If piping attachment cause the impeller clearance to change, correct piping. For setting instructions see section 6.7, *Setting impeller clearance*.

**5.4 Direction of rotation**

  Serious damage can result if the pump is started or run in the wrong direction of rotation.

The pump is shipped with the coupling element removed. Ensure the direction of rotation of the motor is correct before fitting the coupling element. Direction of rotation must correspond to the direction arrow.

  If maintenance work has been carried out to the site's electricity supply, the direction of rotation should be re-checked as above in case the supply phasing has been altered.

**5.5 Guarding**

 Guarding is supplied fitted to the pump set.



In member countries of the EU and EFTA, it is a legal requirement that fasteners for guards must remain captive in the guard to comply with the Machinery Directive 2006/42/EC.

When releasing such guards, the fasteners must be unscrewed in an appropriate way to ensure that the fasteners remain captive.



Whenever guarding is removed or disturbed ensure that all the protective guards are securely refitted prior to start-up.

**5.6 Priming and auxiliary supplies**









**5.6.1 Filling and priming**

  The pump end needs to be completely submerged in the product.

**5.6.2 Auxiliary supplies**

  Ensure all electrical, hydraulic, pneumatic, sealant and lubrication systems (as applicable) are connected and operational.

**5.7 Starting the pump**

- a)   Ensure flushing and/or cooling/heating liquid supplies are turned ON, before starting pump.
- b) CLOSE the outlet valve partially, but ensure that air is allowed to escape out of the discharge pipe. This is especially important for pumps with product lubricated line bearings.
- c)   Ensure that the liquid level in the sump is above the minimum pump casing submergence level.
- d)   Ensure all vent valves are closed before starting.
- e) Start motor and check the outlet pressure.
- f) If the pressure is satisfactory, SLOWLY open the outlet valve.
- g)   Do not run the pump with the outlet valve completely closed.
- h) If NO pressure, or LOW pressure, STOP the pump. Refer to section 7, *Faults; causes and remedies* for fault diagnosis.

## 5.8 Running the pump

### 5.8.1 Pump end mechanical seals

Mechanical seals require no adjustment. Any slight initial leakage will stop when the seal is run in.

Before pumping dirty liquids it is advisable, if possible, to run the pump in using clean liquid to safeguard the seal face.

 External flush shall be started before the pump is run and allowed to flow for a period after the pump has stopped.

### 5.8.2 Thrust bearings



If the pumps are working in a potentially explosive atmosphere without regular monitoring, temperature monitoring of the thrust bearing is recommended. For temperature classes T5 and T6 thrust bearing monitoring must be fitted.

If the thrust bearing temperatures are to be monitored it is essential that a benchmark temperature is recorded at the commissioning stage and after the bearing temperature has stabilized.

- Record the bearing temperature (t) and the ambient temperature (ta)
- Estimate the likely maximum ambient temperature (tb)
- Set the alarm at  $(t+tb-t_a+5) \text{ } ^\circ\text{C}$  ( $t+tb-t_a+10 \text{ } ^\circ\text{F}$ ) and the trip at  $100 \text{ } ^\circ\text{C}$  ( $212 \text{ } ^\circ\text{F}$ ) for oil lubrication and  $105 \text{ } ^\circ\text{C}$  ( $220 \text{ } ^\circ\text{F}$ ) for grease lubrication. Ensure that the ATEX temperature class limit is not exceeded if the pump is operating in a hazardous area. The normal bearing temperature  $T_n$  is  $t+t_b-t_a$  where  $T_n < T_c$ . In the case of T5 and T6, the critical bearing temperature  $T_c = 65 \text{ } ^\circ\text{C}$  (T6) or  $80 \text{ } ^\circ\text{C}$  (T5)

It is important, particularly with grease lubrication, to keep a check on bearing temperatures. After start-up the temperature rise should be gradual, reaching a maximum after approximately 1.5 to 2 hours. This temperature rise should then remain constant or marginally reduce with time. (Refer to section 0 for further information.)

### 5.8.3 Normal vibration levels, alarm and trip

For guidance, pumps generally fall under a classification for rigid support machines within the International rotating machinery standards and the recommended maximum levels below are based on those standards.

 Regular monitoring of the pump vibration is recommended to show any deterioration in pump or system operating conditions. The vibration is measured adjacent to the pump thrust bearing.

 Alarm and trip values for installed pumps should be based on the actual measurements (N) taken on the pump in the fully commissioned as new condition.

For remote installations continuous monitoring and automatic alert and shutdown is recommended.

Vibration velocity – unfiltered mm/s (in./sec) r.m.s.		
Normal	<b>N</b>	$\leq 7.1 (0.28)$
Alarm	<b>N x 1.25</b>	$\leq 9.0 (0.35)$
Shutdown trip	<b>N x 2.0</b>	$\leq 14.2 (0.56)$

Where pumps operate in a hazardous area refer to section 1.6.4.3 and 4.7 for the requirements for monitoring and protective systems.

### 5.8.4 Stop/start frequency

Pump sets are normally suitable for the number of equally spaced stop/starts per hour shown in the table below. Check capability of the driver and control/starting system before commissioning.

Motor rating kW (hp)	Maximum stop/starts per hour
Up to 15 (20)	15
Between 15 (20) and 90 (120)	10
Above 90 (120)	6

Where duty and standby pumps are installed it is recommended that they are run alternately every week.

## 5.9 Stopping and shutdown

a)  Close the outlet valve, but ensure that the pump runs in this condition for no more than a few seconds.

b) Stop the pump.

c) Switch off flushing and/or cooling/heating liquid supplies/electrics at a time appropriate to the process.

d)  For prolonged shut-downs and especially when ambient temperatures are likely to drop below freezing point, the pump and any cooling and flushing arrangements must be drained or otherwise protected.

## 5.10 Hydraulic, mechanical and electrical duty

This product has been supplied to meet the performance specifications of your purchase order, however it is understood that during the life of the product these may change. The following notes may help the user decide how to evaluate the implications of any change. If in doubt contact your nearest Flowserve office.

### 5.10.1 Specific gravity (SG)

Pump capacity and total head in metres (feet) do not change with SG, however pressure displayed on a pressure gauge is directly proportional to SG.

Power absorbed is also directly proportional to SG. It is therefore important to check that any change in SG will not overload the pump driver or over-pressurize the pump.

### 5.10.2 Viscosity

For a given flow rate the total head reduces with increased viscosity and increases with reduced viscosity. Also for a given flow rate the power absorbed increases with increased viscosity, and reduces with reduced viscosity. It is important that checks are made with your nearest Flowserve office if changes in viscosity are planned.

### 5.10.3 Pump speed

Changing pump speed effects flow, total head, power absorbed,  $NPSH_R$ , noise and vibration. Flow varies in direct proportion to pump speed, head varies as speed ratio squared and power varies as speed ratio cubed. The new duty, however, will also be dependent on the system curve. If increasing the speed, it is important therefore to ensure the maximum pump working pressure and critical shaft speed are not exceeded, the driver is not overloaded,  $NPSH_A > NPSH_R$ , and that noise and vibration are within local requirements and regulations.

### 5.10.4 Net positive suction head ( $NPSH_A$ )

$NPSH$  available ( $NPSH_A$ ) is a measure of the head available in the pumped liquid, above its vapor pressure, at the pump suction branch.

$NPSH$  required ( $NPSH_R$ ) is a measure of the head required in the pumped liquid, above its vapor pressure, to prevent the pump from cavitating.

It is important that  $NPSH_A > NPSH_R$ . The margin between  $NPSH_A > NPSH_R$  should be as large as possible.

If any change in  $NPSH_A$  is proposed, ensure these margins are not significantly eroded. Refer to the pump performance curve to determine exact requirements particularly if flow has changed.

If in doubt please consult your nearest Flowserve office for advice and details of the minimum allowable margin for your application.

### 5.10.5 Pumped flow

Flow must not fall outside the minimum and maximum continuous safe flow shown on the pump performance curve and or data sheet.

## 6 MAINTENANCE

### 6.1 General



It is the plant operator's responsibility to ensure that all maintenance, inspection and assembly work is carried out by authorized and qualified personnel who have adequately familiarized themselves with the subject matter by studying this manual in detail. (See also section 1.6.)

Any work on the machine must be performed when it is at a standstill. It is imperative that the procedure for shutting down the machine is followed, as described in section 5.9.

Guard fasteners must remain captive during dismantling of guards, as described in section 5.5. On completion of work, all guards and safety devices must be re-installed and made operative again.

Before restarting the machine, the relevant instructions listed in section 5, *Commissioning, start-up, operation and shut down*, must be observed.

***Oil and grease leaks may make the ground slippery. Machine maintenance must always begin and finish by cleaning the ground and the exterior of the machine.***

If platforms, stairs and guard rails are required for maintenance, they must be placed for easy access to areas where maintenance and inspection are to be carried out. The positioning of these accessories must not limit access or hinder the lifting of the part to be serviced.

When air or compressed inert gas is used in the maintenance process, the operator and anyone in the vicinity must be careful and have the appropriate protection.

Do not spray air or compressed inert gas on skin.

Do not direct an air or gas jet towards other people.

Never use air or compressed inert gas to clean clothes.

Before working on the pump, take measures to prevent an uncontrolled start. Put a warning board on the starting device with the words:

**"Machine under repair: do not start".**

With electric drive equipment, lock the main switch open and withdraw any fuses. Put a warning board on the fuse box or main switch with the words:

**"Machine under repair: do not connect".**

Never clean equipment with inflammable solvents or carbon tetrachloride. Protect yourself against toxic fumes when using cleaning agents.

## 6.2 Maintenance schedule



It is recommended that a maintenance plan and schedule is adopted, in line with these User Instructions, to include the following:

- Any auxiliary systems installed must be monitored, if necessary, to ensure they function correctly.
- Check for any leaks from gaskets and seals. The correct functioning of the shaft seal must be checked regularly.
- Check bearing lubricant coolant.
- Check that the duty condition is in the safe operating range for the pump.
- Check vibration, noise level and surface temperature at the bearings to confirm satisfactory operation.
- Check dirt and dust is removed from areas around close clearances, bearing housings and motors.
- Check flexible coupling alignment and re-align if necessary.

Our specialist service personnel can help with preventative maintenance records and provide condition monitoring for temperature and vibration to identify the onset of potential problems.

If any problems are found the following sequence of actions should take place:

- Refer to section 7, *Faults; causes and remedies*, for fault diagnosis.
- Ensure equipment complies with the recommendations in this manual.
- Contact Flowserve if the problem persists.

### 6.2.1 Routine inspection (daily/weekly)



The following checks should be made and appropriate action taken to remedy any deviations:

- Check operating behaviour. Ensure noise, vibration and bearing temperatures are normal.
- Check that there are no abnormal fluid or lubricant leaks (static and dynamic seals) and that any sealant systems (if fitted) are full and operating normally.
- Check that shaft seal leaks are within acceptable limits.
- Check the level and condition of line bearing coolant. (On grease lubricated pumps, check running hours since last recharge of grease or complete grease change.)
- Check any auxiliary supplies e.g. heating/cooling/lubrication (if fitted) are functioning correctly.
-  Refer to the manuals of any associated equipment for routine checks needed.

### 6.2.2 Periodic inspection (six monthly)



- Check foundation bolts for security of attachment and corrosion.
- Check pump running records for hourly usage to determine if bearing lubricant requires changing.
- The coupling should be checked for correct alignment and worn driving elements.
-  Refer to the manuals of any associated equipment for periodic checks needed.

### 6.2.3 Re-lubrication

For general guidelines refer to section 0, *Lubrication schedule*.

Lubricant and bearing temperature analysis can be useful in optimizing lubricant change intervals.

### 6.2.4 Mechanical seals

When leakage becomes unacceptable the seal will need replacement.

## 6.3 Spare parts

### 6.3.1 Ordering of spares

Flowserve keeps records of all pumps that have been supplied. When ordering spares the following information should be quoted.

- Pump serial number.
- Pump size.
- Part name – taken from section 8.
- Part number – taken from section 8.
- Number of parts required.

The pump size and serial number are shown on the pump nameplate.

To ensure continued satisfactory operation, replacement parts to the original design specification should be obtained from Flowserve. Any change to the original design specification (modification or use of a non-standard part) will invalidate the pump safety certification.

**6.3.2 Storage of spares**

Spares should be stored in a clean dry area away from vibration. Inspection and re-treatment of metallic surfaces (if necessary) with preservative is recommended at 6 monthly intervals.

**6.4 Recommended spares**

(For two years operation - as per VDMA 24296)

Part no.	Designation	Number of pumps (including stand-by)						
		2	3	4	5	6/7	8/9	10(+)
2100	Shaft	1		2			3	30%
2200	Impeller	1			2		3	30%
2400.1	Shaft sleeve - pump end	2			3		4	50%
3013	Bearing - thrust	1		2		3	4	50%
3300.1	Bearing - pump end	1		2		3	4	50%
3300.2	Bearing - lineshaft *	1		2		3	4	50%
3400.1	Shaft sleeve - intermediate *	2			3		4	50%
3712	Bearing nut	1		2		3	4	50%
4200	Mechanical seals *	1		2		3		30%
2400.2	Sleeve - mechanical seal *	2			3		4	50%
6570.9	Shaft sleeve screw for 3400.1 *	2		3		4		50%
4590.1**	Pump casing gasket	4			6		8	9
4590.2	Discharge flange gasket	4	6	8	9	10	100%	
4610.1	O-ring impeller	4			6		8	9
4610.2	O-ring carrier	2	3	4	50%	12	150%	
4610.3	O-ring mechanical seal sleeve *	2	3	4	50%	12	150%	

\* When required due to fitting as part of the original build specification.

**Additional spares for keyed A-OP impeller option**

2912.1/ 2912.2	Impeller nut	1		2		3	30%
4610.5	O-ring impeller	4	6	8	9	12	150%
6700.2	Impeller key	1		2		3	30%

**6.5 Tools required**

A typical range of tools that will be required to maintain these pumps is listed below:

*Readily available in standard tool kits, and dependent on pump size:*

- Open ended spanners (wrenches) to suit up to M 48 screws/nuts
- Socket spanners (wrenches), up to M 48 screws
- Allen keys, up to 10 mm (A/F)

- Range of screwdrivers
- Soft mallet

*More specialized equipment:*

- Bearing pullers
- Bearing induction heater
- Dial test indicator
- C-spanner (wrench) - for removing shaft nut. (If difficulties in sourcing are encountered, consult Flowserve.)

**6.6 Casing, seal housing and fastener torques**

Fastener	Screw size	Torque Nm (lb•ft)
All except where otherwise stated	M8	16 (12)
	M10	25 (18)
	M12	35 (26)
	M16	80 (59)
	M20	130 (96)
Impeller nut	M12	16 (12)
	M16	41 (31)
	M22	106 (79)
	M24	135 (100)



Non-metallic gaskets incur creep relaxation - before commissioning the pump check and retighten fasteners to tightening torques stated.

Note:

For the tightening sequence also refer to good industry practice. See section 10.3, *Reference 6*, for more detail.

**6.7 Setting impeller clearance**

This procedure may be required after the pump has been dismantled or a different clearance is required.

For the OP front open impeller clearance setting this is as shown in the table.

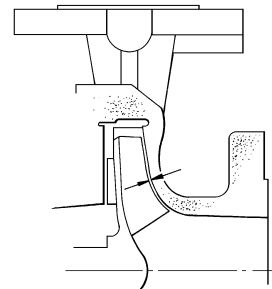

Temperature °C (°F)	ISO impeller front clearance mm (in.)		
	Impellers up to 210 mm	Impellers 211 mm to 260 mm	Impellers over 260 mm*
50 (122)	0.3 (0.012)	0.4 (0.016)	0.5 (0.020)
100 (212)	0.4 (0.016)	0.5 (0.020)	0.6 (0.024)
	ASME impeller clearance		
	All impeller diameters		
50 (120)	0.45 mm (0.018 in.)		
100 (210)	0.55 mm (0.022 in.)		

For the R low shear impeller, the back rear impeller clearance is the setting. Set the back as shown in the following illustration:

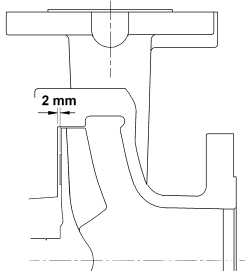

- a) Before carrying out this procedure ensure that any mechanical seal(s) fitted can tolerate a change in their axial setting, otherwise it will be necessary to dismantle the unit and reset the seal axial position after adjusting the impeller clearance.
- b) **Some mechanical seal types may be impaired if moved more than 0.5 mm (0.02 in.) from their nominal setting.**
- c) Disconnect the coupling if it has limited axial flexibility.
- d) Record the gap between the bearing carrier [3240] and motor pedestal [3160] using feeler gauges.

**6.7.1 For OP impellers only**

- a) Loosen the bearing carrier screws [6570.7] and back off the bearing carrier using screws [6570.6].
- b) Ensure the carrier jacking screws [6570.7] are slackened off evenly so as to draw the bearing carrier towards the sole plate, until the impeller just contacts the pump casing. Turn the shaft [2100], during this procedure, until a detectable rub is obtained. This is the zero clearance position.

**Note:** The shaft must be turned in the direction indicated on the casing and sole plate.

- c) Set a dial indicator to zero on the shaft end or measure the bearing carrier [3240] to motor pedestal [3160] gap and record the measurement.
- d) Ensure carrier screws [6570.7] are still slack and tighten the bearing carrier jacking screws [6570.6] evenly (about one flat at a time) until the dial indicator or feeler gauge shows the correct impeller clearance from the zero clearance position. This clearance should be between 0.3 and 0.6mm (0.012 and 0.024 in.) depending on the OP impeller in the table above.
- e) Evenly tighten the bearing carrier screws [6570.7] keeping the dial indicator or feeler gauges reading the correct setting. Then tighten the hexagon nuts [6580.5] to lock the jacking screws [6570.6] in position.

- f) Compare the original and final gaps between the bearing carrier and sole plate to check if the movement of the shaft has exceeded the mechanical seal capability (over/under compression of the seal). Re-position the seal to correct this.
- g) Check that the shaft can turn freely without binding.
- h) Ensure the coupling distance between shaft ends (DBSE) is correct. Reset/re-align if necessary.

**6.7.2 For R low shear (recessed impeller) only**

- a) The impeller has a rear clearance setting.
- b) Loosen the bearing carrier nuts [6580.5] and screws [6570.7].
- c) Tighten the bearing carrier screws [6570.6] evenly, pushing the bearing carrier away from the sole plate, until the impeller contacts the cover [1220]. Turn the shaft [2100], during this procedure, until a detectable rub is obtained. This is the zero clearance position.

**Note:** The shaft must be turned in the direction indicated on the casing and sole plate.

- d) Set a dial indicator to zero on the shaft end or measure the bearing carrier [3240] to motor pedestal [3160] gap and record the measurement.
- e) Ensure carrier screws [6570.7] are still slack and slacken the bearing carrier [6570.6] screws evenly (about one flat at a time) until the dial indicator or feeler gauge shows the correct ASME recessed impeller rear clearance from the zero clearance position.
- f) Evenly tighten the bearing carrier screws [6570.7] keeping the dial indicator or feeler gauges reading the correct setting. Then tighten the hexagon nuts [6580.5] to lock the jacking screws [6570.6] in position.
- g) Re-position the seal to correct this.
- h) Check that the shaft can turn freely without binding.
- i) Ensure the coupling distance between shaft ends (DBSE) is correct. Reset/re-align if necessary.

**6.7.3 For RV reverse vane only**

For the reverse vane (RV) impeller the rear clearance setting is as shown in the table below.

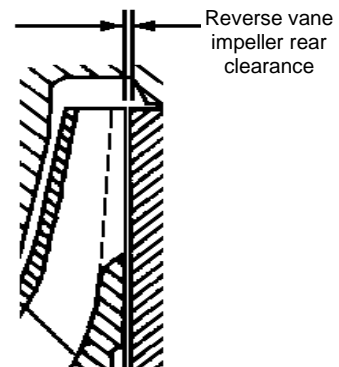

Temperature °C (°F)	ASME RV impeller clearance setting
	All impeller diameters
50 (120)	0.45 mm (0.018 in.)
100 (210)	0.55 mm (0.022 in.)

- Loosen the bearing carrier screws [6570.7] and tighten the bearing carrier using jacking screws [6570.6].
- Ensure the carrier jacking screws [6570.6] are tightened evenly so as to draw the bearing carrier away from the sole plate, until the impeller just contacts the cover [1220]. Turn the shaft [2100] during this procedure until a detectable rub is obtained. This is the zero clearance position. The shaft must be turned in the direction indicated on the casing and sole plate.
- Set a dial indicator to zero on the shaft end or measure the bearing carrier [3240] to motor pedestal [3160] gap and record the measurement.
- Ensure carrier screws [6570.7] are still slack and slacken off the bearing carrier jacking screws [6570.6] evenly (about one flat at a time) until the dial indicator or feeler gauge shows the correct impeller rear clearance from the zero clearance position. This clearance should be between 0.45 and 0.55 mm (0.018 and 0.022 in.) depending on the temperature of the pumped fluid, as in the table above.
- Evenly tighten the bearing carrier screws [6570.7] keeping the dial indicator or feeler gauges reading the correct setting. Then tighten the hexagon nuts [6580.5] to lock the jacking screws [6570.6] in position.
- Compare the original and final gaps between the bearing carrier and sole plate to check if the movement of the shaft has exceeded the mechanical seal capability (over/under compression of the seal). Re-position the seal to correct this.
- Check that the shaft can turn freely without binding.
- Ensure the coupling distance between shaft ends (DBSE) is correct. Reset/re-align if necessary.

### 6.8 Renewal clearances

As wear takes place between the impeller and casing ring the overall efficiency of the pump set will decrease. To maintain optimum efficiency it is recommended that the clearances shown in section 6.7, *Setting impeller clearance*, are maintained.

On product lubricated bearings it is recommended that these are renewed at the diametrical clearance in the as fitted condition stated in the following table:

Bearing sleeve size mm (in.)	Sleeve diameter/tolerance min diam - max diam mm (in.)		Bearing clearance (max/min) mm (in.)
	45 (1.770)	45.00 (1.7717)	
65 (2.559)	64.98 (2.5583)	65.00 (2.5591)	0.35/0.19 (0.0138/0.0075) 0.39/0.23 (0.0154/0.0091)

### 6.9 Disassembly

Refer to *Safety*, section 1.6, before dismantling the pump.

**CAUTION** Before dismantling the pump for overhaul, ensure genuine Flowserve replacement parts are available. Refer to sectional drawings for part numbers and identification. (See section 8, *Parts lists and drawings*.)

**CAUTION** When taking out the pump be sure to drain off coolant from the drain plug [6569.1/6569.2] while the pump is still vertical to ensure none enters and contaminates the thrust bearing housing.

#### 6.9.1 Pump disassembly

- Disconnect all auxiliary pipes and tubes where applicable.
- Disconnect all discharge and auxiliary pipework.
- Remove coupling guard [7450], disconnect coupling [7000] and remove motor [8100].
- If oil lubricated unit, drain oil.
- Remove nuts securing sole plate to foundations and lift the complete unit clear.
- Record the gap between bearing carrier [3240] and sole plate [6140] so that this setting can be used during workshop assembly.
- Remove suction pipe and/or strainer [6531] if fitted.
- Remove all flushing lines as appropriate, casing screws and discharge flange bolts.
- Remove pump casing [1100].
- Remove pump casing [4590.1] and discharge flange [4590.2] gaskets and discard. (Replacement gaskets will be required for assembly.)
- Clean the gasket mating surfaces.

#### 6.9.2 Impeller removal

**NEVER APPLY HEAT TO REMOVE THE IMPELLER. TRAPPED WORKING LIQUID OR LUBRICANT MAY CAUSE AN EXPLOSION.**

##### 6.9.2.1 Impeller removal with threaded on impeller

- Fit a chain wrench or bolt a bar to the holes in the coupling half, or fit a keyed shaft wrench directly to the shaft.



- b) Wearing metal mesh reinforced gloves, rotate the shaft [2100s] by turning the impeller [2200] clockwise as viewed from the impeller end of the shaft, so that the wrench makes contact with one of the supports of the motor pedestal [3160].
- c) Give the impeller a quick turn counter-clockwise so that the wrench handle strikes the other side of the window edge of the motor pedestal [3160]. A few sharp strikes will loosen one of the shaft threads. If at this point the impeller is still firmly threaded to the pump end shaft [2100], then the thread of an inter-shaft will have started to disengage.
- d) If the impeller is loose then unscrew it and discard the impeller O-ring [4610.1]. Use a new O-ring for assembly.

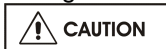

The single mechanical seal distance ring [2510] is a slide fit on the back of the impeller, take care not to drop this when bringing the impeller off the shaft.

- e) In case one of the shafts start to disengage at another thread ensure both sections of the column are well supported. Unscrew the screws and nuts [6570 & 6580] at the loose joint. Unscrew the shaft [2100s] taking great care to support both shaft ends when they disengage to avoid damaging the line bearings.
- f) Remove the lower section of the support column and place on a level support structure.
- g) If the pump contains more than one shaft, it can be more efficient to remove the highest column pipe section by removing the studs and nuts [6572.2 & 6580.4]. Then slide the support pipe and line bearing assembly over the shaft while ensuring the shaft is well supported. Remove the free section of shaft [2100s]. Repeat the above until only the lowest section of the support column pipe [1350] remains.
- h) Fix the lowest section of the support column on a workbench. Fit a spanner to the flats of the upper end of the shaft and ensure it can not slip.
- i) Fit a strap wrench around the impeller and spin the impeller clockwise to lift the spanner from the work bench.
- j) Spin the impeller quickly counter-clockwise with the wrench to get the spanner to make impact on the workbench or a wooden block. The impact will loosen the impeller.
- k) Unscrew the impeller and discard the impeller O-ring [4610.1]. Use a new O-ring for assembly.

#### 6.9.2.2 Impeller removal with key drive impeller

- a) Remove impeller locking nut [2912] complete with O-ring [4610.5], which should be discarded. (A new O-ring will be required for assembly.)
- b) Pull impeller [2200] off shaft.

- c) Remove impeller key [6700.2].
- d) Remove impeller sealing gasket [4590.4] and discard. (A new sealing gasket will be required for assembly.)

#### 6.9.3 Mechanical seal, support columns, shafts and bearings

Note:

- a) Take extreme care with silicon carbide or carbon-graphite seal faces or bearings to avoid chipping or cracking these relatively brittle components.
- b) For the dual mechanical seal option, remove the cover fasteners [1220.2]. Remove the cover [1220.2] taking care not to drop the inboard seal face which is a press fit in the back of the cover.
- c) Slide off the sleeve [2400.1] to which the seal [4200] rotary(s) is fitted and which should come away together.
- d) On the single mechanical seal now remove the fasteners which fix the cover [1220.1]. Remove the cover [1220.1] taking care not to drop the seal face which is a press fit into the cover.
- e) Note: When removing the mechanical seal [4200] from the sleeve refer to the specific manufacturer's instructions for the mechanical seal.
- f) Remove the screw and nut [6570.1 & 6580.3] holding the next item [1350.4 or 4212] and its O-ring [4610].
- g) Slide out the bearing support [3250.1].
- h) Unbolt and remove support column [1350.3].
- i) Unscrew the overhanging shaft [2100] section prior to removing the next section of support column.
- j) Any long length of shaft should be temporarily supported to avoid bending or damage whilst removing the optional shaft split coupling(s) [7120].

#### 6.9.4 Bearings and upper shaft

- a) Remove the bearing housing screws.
- b) Pull the bearing carrier [3240] and upper shaft assembly out of the sole plate. Take care to support the long shaft to avoid bending or damage to it and any attached components.
- c) Pull off the coupling [7000] hub and remove the coupling key [6700].
- d) Drive out labyrinth seal [4330] (if fitted).
- e) Unscrew the bearing outer nut [3712.2] (left hand thread).
- f) Remove the drive side flinger or labyrinth seal (if fitted) from the shaft.
- g) Slide the bearing carrier off of the bearing(s).
- h) Remove the bearing shaft nut [3712.1].
- i) Pull off the bearing(s) [3013].
- j) Any bearings or sleeves can then be pressed out or off, as required.

## 6.10 Examination of parts

 Used parts must be inspected before assembly to ensure the pump will subsequently run properly. In particular, fault diagnosis is essential to enhance pump and plant reliability.

### 6.10.1 Casing, seal housing and impeller

Inspect for excessive wear, pitting, corrosion, erosion or damage and any sealing surface irregularities. Replace as necessary.

### 6.10.2 Shaft and sleeve (if fitted)

Obtain and fit a new shaft [2100] or sleeve [2400.1] if grooved, pitted or worn.

### 6.10.3 Gaskets and O-rings

After dismantling, discard and replace.

### 6.10.4 Bearings

It is recommended that bearings [3013] are not re-used after any removal from the shaft.

The plain bearings may be re-used if both the bearing bush [3300] and bearing sleeve [3400] show no sign of wear, grooving or corrosion attack. It is recommended that both the bush and sleeve are replaced at the same time.

## 6.11 Assembly

To assemble the pump consult the sectional drawings. (See section 8, *Parts lists and drawings*.)

Ensure threads, gasket and O-ring mating faces are clean. Apply thread sealant to non-face sealing pipe thread fittings.

### 6.11.1 Mechanical seal

Extreme cleanliness is required during assembly. Check that the sealing faces are free from scratches or other damage.

- a) Use water for fitting elastomers.
- b) Where an anti-rotation pin is fitted ensure that it is correctly engaged with the slot.
- c) Carefully press stationary mechanical seal seat(s) into their housing so that they are not deformed or damaged.

 Work to the specific manufacturer's instructions for the mechanical seal.

### 6.11.2 Thrust bearing carrier and shaft sub-assembly

- a) Fit deflector [2540] with its O-ring and screw [4610.3 & 6570.10] onto the shaft.

- b) Clean the inside of the bearing carrier and bores for the bearings.
- c) On grease lubricated bearings fill the bearing nut [3712.2] internal slot with the appropriate grease. The three thin grease rings may now be inserted into this internal slot.
- d) The bearing carrier retaining ring sub-assembly and bearing sleeve [2400.3], applicable on shaft sizes 3 and 4, should now be placed over the shaft before fitting the thrust bearing. The retaining ring must have the C spanner slots facing the impeller end.
- e) Press the thrust bearing(s) [3013] onto the shaft using equipment that can provide a steady, even load to the inner race.
- f) Oil bath lubricated thrust bearing is an option.
- g) If grease lubrication as standard, use a spatula to fill sides of the bearing with grease of NLGI 3 grade.

 On aggressive solvent/acid vapor service a special fluoro-silicone grease (Molykote FS3451) may be required. Pack the bearing fully by hand as no grease nipple is used in the design.

- h) Fit the self-locking thrust bearing nut [3712] onto the shaft and tighten with a C spanner.
- i) Fit O-ring [4610.2] on the bearing carrier [3240] and lubricate the bearing carrier bore and O-ring with oil.
- j) Ensure the shaft coupling keyway edges are free of burrs. If optional proprietary labyrinth type bearing housing seals [4330] are used the O-rings should be oiled to assist assembly.
- k) Install the bearing carrier onto the shaft/bearing assembly and screw the bearing carrier locking ring into the bearing carrier. Tighten up the bearing carrier locking ring using a C spanner.

 LH thread.

- l) Check shaft [2100] for free rotation.
- m) To fit an inter bearing shaft sleeve [3400], slide it over the shaft from the impeller end and tighten up the sleeve drive screw [6570.9].
- n) To fit the pump end sleeve [2400.1], slide it over the shaft; this is driven by the impeller.

### 6.11.3 Bearing bushes

- a) If due to the pit depth and pump speed an intermediate bearing bush [3300s] is fitted, press this into the upper support column. The pump end bush [3300.2] is fitted into the pump end bearing support [3250.2].
- b) When fitting the intermediate bearing bush, or pump end bearing bush, press these in chamfered end first.

 Check the orientation so that the locking pegs [6570.11 and 6570.12] line up correctly.

#### 6.11.4 Installing the shaft sub-assembly

- a) Before assembling the shaft sub-assembly into the sole plate, fasten the upper suspension pipe/bearing bush sub-assembly to the sole plate.
- b) If the sump is short there may be no column pipes above [1350.3]. In this case, the lower column pipe will need to be fitted to the sole plate to support the shaft sub-assembly. The bearing support [3250.2] should only be fitted after the shaft sub-assembly.

**Note:**

If there is an upper column pipe [1350.2], the lower column pipe and pump end bearing support [3250.1] must only be fitted after the shaft sub-assembly. Install the shaft assembly into the motor stool and sole plate until the bearing carrier [3240] gap is approximately 4 mm (0.16 in.).

- c) Install the bearing carrier hexagon screws [6570.7] and the hexagon screws [6570.6] and hexagon nuts [6580.5], but do not tighten.
- d) Where a labyrinth [4330] has not been provided press the external deflector [2540] onto the shaft, where applicable. This should be set between 0.5 and 2 mm (0.02 and 0.08 in.) from the bearing carrier [3240].
- e) Turn the shaft [2100] to check for freedom from rubbing.
- f) Refit the coupling [7000].

#### 6.11.5 Impeller and casing assembly

##### 6.11.5.1 Impeller assembly with threaded on impeller

- a) Fit a new O-ring [4610.1] into the impeller using a small amount of grease to hold it in place. Apply anti-galling compound (which does not contain copper) to the impeller thread to help subsequent removal.
- b) Assemble impeller [2200] onto the shaft [2100].
- c) Tighten the impeller. Use the same method as in disassembly but rotate in opposite direction. A few sharp strikes will tighten it to the correct level.
- d) Clean the casing spigot and gasket position mating surfaces.
- e) Fit a new casing gasket [4590.1].
- f) Install the pump casing with a new casing to discharge gasket [4590.2].
- g) Install casings studs [6572.1] and nuts [6580.8] to the specified torques.
- h) Check impeller front clearance against original setting, or process requirement, and adjust as necessary. (See section 6.7, *Setting impeller clearance*.)
- i) Check freedom to rotate within pump casing.

##### 6.11.5.2 Impeller assembly with key drive impeller

- a) Fit a new impeller sealing gasket [4590.4] against shaft shoulder.
- b) Fit impeller key [6700.2].
- c) Assemble impeller [2200] onto the shaft [2100].
- d) Fit a new O-ring [4610.5] into the impeller locking nut groove.
- e) Apply anti-galling compound (which does not contain copper) to the impeller nut threads to help any subsequent removal.
- f) Fit impeller nut [2912] onto the shaft and torque up.
- g) Clean the casing spigot and gasket position mating surfaces.
- h) Fit a new casing gasket [4950.1].
- i) Install the pump casing with a new casing to discharge gasket [4950.2].
- j) Install casing hexagon screws [6570.2] to the specified torques.
- k) Check impeller front clearance against original setting, or process requirement and adjust as necessary. (See section 6.7, *Setting impeller clearance*.)
- l) Check freedom to rotate within pump casing.

##### 6.11.6 Coupling, motor and ancillaries

- a) Reconnect pump ancillary fittings and piping.
- b) Install pump into sump and connect up remaining fittings and piping.
- c) Re-check freedom of shaft to rotate by hand.
- d) Re-install motor (check for correct rotation) and then fit coupling drive element and guards.
- e) If all is correct continue with the procedure described under Section 4, *Installation*, and section 5, *Commissioning, start-up, operation and shutdown*.

## 7 FAULTS; CAUSES AND REMEDIES

### FAULT SYMPTOM

Pump overheats and seizes														
↓	Bearings have short life													
↓	Pump vibrates or is noisy													
↓	Mechanical seal has short life													
↓	Mechanical seal leaks excessively													
↓	Pump requires excessive power													
↓	Pump loses prime after starting													
↓	Insufficient pressure developed													
↓	Insufficient capacity delivered													
↓	Pump does not deliver liquid													
					<b>POSSIBLE CAUSES</b>					<b>POSSIBLE REMEDIES</b>				
<b>A. System troubles</b>														
●	●						●	●	Insufficient margin between suction pressure and vapor pressure.	Check $NPSH_A > NPSH_R$ , proper submergence, losses at strainers and fittings.				
						●	●	●	Excessive amount of air or gas in liquid.	Check and purge pipes and system.				
						●	●	●	Inlet of suction pipe insufficiently submerged.	Check out system design.				
							●	●	Speed too low.	CONSULT FLOWSERVE.				
								●	Speed too high.	CONSULT FLOWSERVE.				
							●	●	Total head of system higher than differential head of pump.	Check system losses. Remedy or CONSULT FLOWSERVE.				
							●		Total head of system lower than pump design head.					
							●		Specific gravity of liquid different from design.	Check and CONSULT FLOWSERVE.				
							●	●	Viscosity of liquid differs from that for which designed.					
●	●								Operation at very low capacity.	Measure value and check minimum permitted. Remedy or CONSULT FLOWSERVE.				
●	●								Operation at high capacity.	Measure value and check maximum permitted. Remedy or CONSULT FLOWSERVE.				
<b>B. Mechanical troubles</b>														
●	●	●	●	●	●				Misalignment due to pipe strain.	Check the flange connections and eliminate strains using elastic couplings or a method permitted.				
									Improperly designed foundation.	Check setting of sole plate: tighten, adjust, grout base as required.				
									Shaft bent.	Check shaft runouts are within acceptable values. CONSULT FLOWSERVE.				
●	●	●							Rotating part rubbing on stationary part internally.	Check and CONSULT FLOWSERVE, if necessary.				
●	●	●	●	●					Bearings worn	Replace bearings.				
								●	Wearing ring surfaces worn.	Replace worn wear ring/surfaces.				
									Impeller damaged or eroded.	Replace or CONSULT FLOWSERVE for improved material selection.				
								●	Leakage under sleeve due to joint failure.	Replace joint and check for damage.				
								●	Shaft sleeve worn or scored or running off centre.	Check and renew defective parts.				
								●	Mechanical seal improperly installed.	Check alignment of faces or damaged parts and assembly method used.				
								●	Incorrect type of mechanical seal for operating conditions.	CONSULT FLOWSERVE.				
●	●	●	●	●					Shaft running off centre because of worn bearings or misalignment.	Check misalignment and correct if necessary. If alignment satisfactory check bearings for excessive wear.				
●	●	●	●	●					Impeller out of balance resulting in vibration.	Check and CONSULT FLOWSERVE.				
								●	Abrasive solids in liquid pumped.					

**FAULT SYMPTOM**

<b>Pump overheats and seizes</b>									
⇓ <b>Bearings have short life</b>									
⇓ <b>Pump vibrates or is noisy</b>									
⇓ <b>Mechanical seal has short life</b>									
⇓ <b>Mechanical seal leaks excessively</b>									
⇓ <b>Pump requires excessive power</b>									
⇓ <b>Pump loses prime after starting</b>									
⇓ <b>Insufficient pressure developed</b>									
⇓ <b>Insufficient capacity delivered</b>									
⇓ <b>Pump does not deliver liquid</b>									
⇓									
					<b>POSSIBLE CAUSES</b>			<b>POSSIBLE REMEDIES</b>	
			●	●				Internal misalignment of parts preventing seal ring and seat from mating properly.	
			●	●				Mechanical seal was run dry.	Check mechanical seal condition and source of dry running and repair.
			●	●				Internal misalignment due to improper repairs causing impeller to rub.	Check method of assembly, possible damage or state of cleanliness during assembly. Remedy or CONSULT FLOWSERVE, if necessary.
●	●	●						Excessive thrust caused by a mechanical failure inside the pump.	Check wear condition of impeller, its clearances and liquid passages.
	●	●						Excessive grease in ball bearings.	Check method of regreasing.
	●	●						Lack of lubrication for bearings.	Check hours run since last change of lubricant, the schedule and its basis.
	●	●						Improper installation of bearings (damage during assembly, incorrect assembly, wrong type of bearing etc).	Check method of assembly, possible damage or state of cleanliness during assembly and type of bearing used. Remedy or CONSULT FLOWSERVE, if necessary.
	●	●						Damaged bearings due to contamination.	Check contamination source and replace damaged bearings.
<b>C. MOTOR ELECTRICAL PROBLEMS</b>									
		●		●	●	●		Wrong direction of rotation.	Reverse 2 phases at motor terminal box.
				●		●		Motor running on 2 phases only.	Check supply and fuses.
	●	●				●		Motor running too slow.	Check motor terminal box connections and voltage.

**8 PARTS LISTS AND DRAWINGS**

**8.1 CPXV-E**

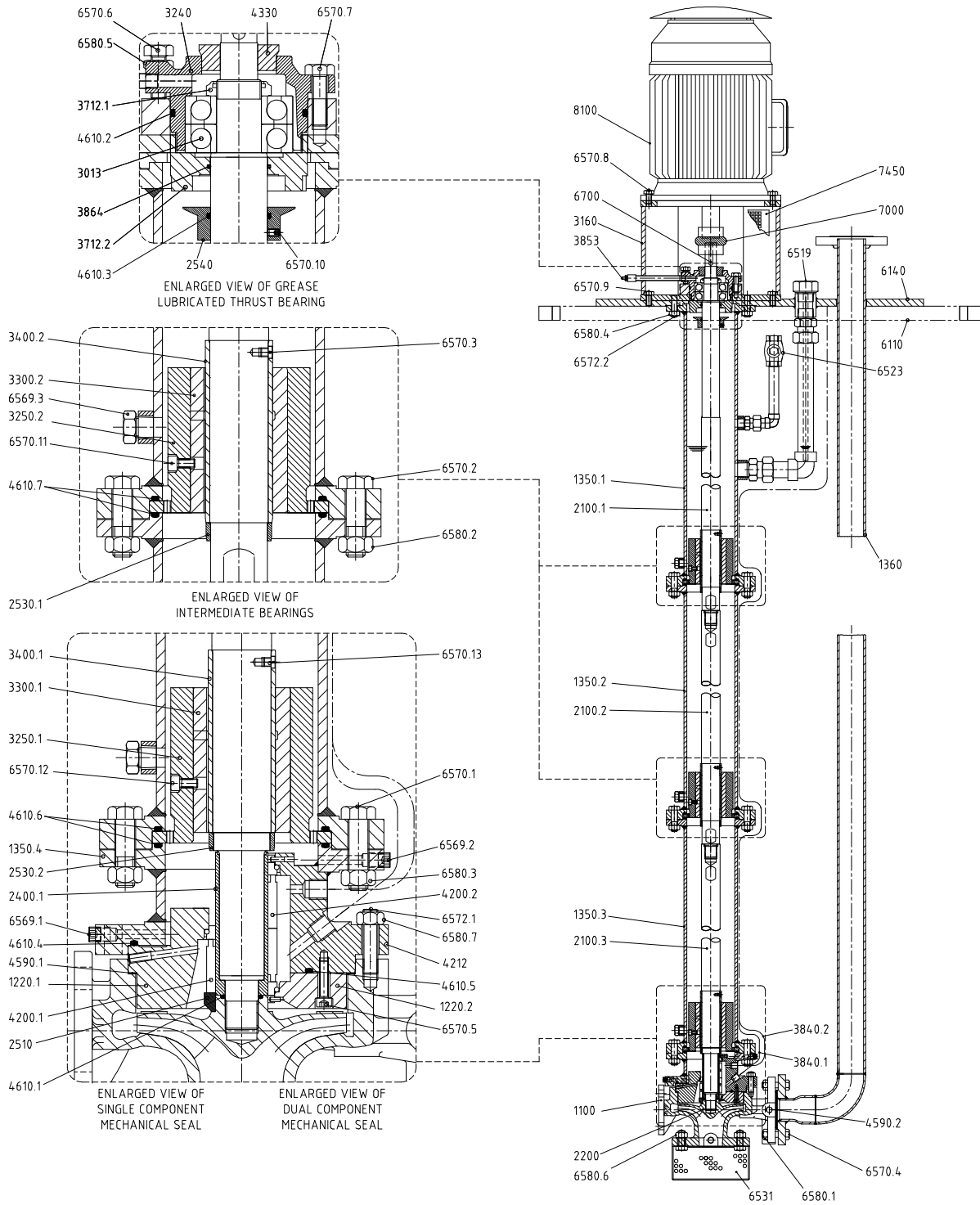

Drawing taken from B736/627 sheet 1, rev B

**8.1.1 CPXV-E parts list**

Item	Description
8100	Motor
7450	Coupling guard
7000	Coupling
6700	Key
6580.7	Nut
6580.5	Nut
6580.4	Nut
6580.3	Nut
6580.2	Nut
6580.1	Nut
6572.2	Stud
6572.1	Stud
6570.13	Screw
6570.12	Screw
6570.11	Screw
6570.1	Screw
6570.9	Screw
6570.8	Screw
6570.7	Screw
6570.6	Screw
6570.4	Screw
6570.3	Screw
6570.2	Screw
6570.1	Screw
6569.3	Plug
6569.1	Plug
6523	Vent valve
6519	Coolant dipstick
6140	Sole plate
4610.7	O-ring
4610.6	O-ring
4610.5	O-ring
4610.4	O-ring
4610.3	O-ring
4610.2	O-ring
4610.1	O-ring
4590.2	Gasket
4590.1	Gasket
4330	Labyrinth ring
4200.1	Mechanical seal (single)
3864	Grease retainer
3853	Grease nipple
3712.2	Bearing lock nut
3712.1	Bearing lock nut
3400.2	Bearing sleeve
3400.1	Bearing sleeve
3300.2	Bearing bush
3300.1	Bearing bush
3250.2	Bearing support
3250.1	Bearing support
3240	Bearing carrier
3160	Motor pedestal
3013	Thrust ball bearing
2540	Deflector
2530.2	Retaining ring
2530.1	Retaining ring
2510	Distance ring
2400.1	Sleeve
2200	Impeller
2100.3	Shaft
2100.2	Shaft
2100.1	Shaft
1360	Discharge pipe

1350.4	Column pipe
1350.3	Column pipe
1350.2	Column pipe
1350.1	Column pipe
1220.1	Cover
1100	Casing

**Optional items**

6580.6	Nut
6570.5	Screw
6569.2	Plug
6531	Suction strainer
6110	Base plate
4610.5	O-ring
4212	Seal cover
4200.2	Mechanical seal (dual)
3840.2	Lubricating pipe
3840.1	Lubricating pipe
1220.2	Cover

**8.2 CPXV-E bearing options**

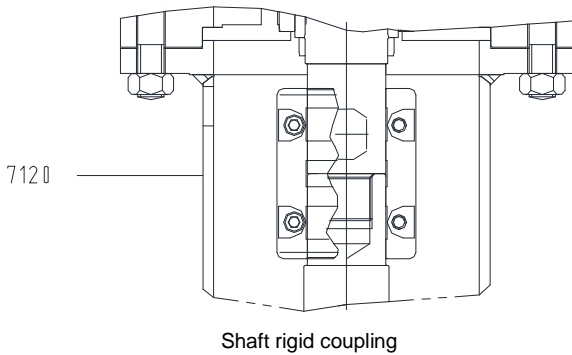

Shaft rigid coupling

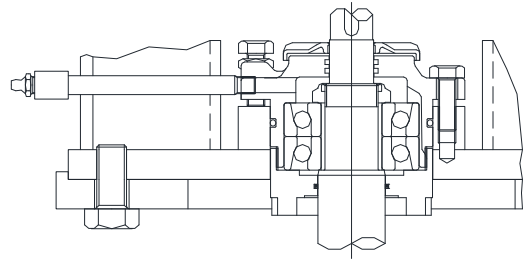

Pair of 40 degree angular contact bearings, grease lubricated. (No sleeve [2400.3] fitted on shaft sizes 1 and 2.)

Drawings taken from B736/048, sheet 3, rev F

**Rigid coupling option**

Item	Description
7120	Split coupling

**Oil lubrication option**

3855	Constant level oiler
4223	Pumping ring
6569.2	Plug (breather)
6569.3	Plug (oil drain)

**Labyrinth ring option**

4330	Labyrinth ring
------	----------------

**Flinger option (short depths)**

2540.2	Deflector
6570.13	Screw

**8.3 Optional A-OP key-drive impeller**

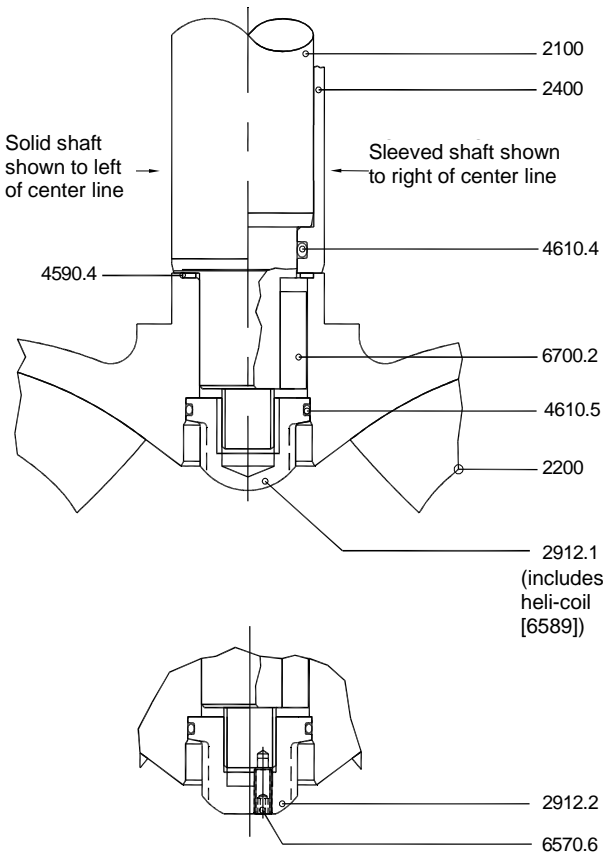

Item	Description
2100	Shaft
2200	Impeller
2400	Sleeve (if fitted)
2912.1	Impeller nut
2912.2	Impeller nut
4590.4	Gasket
4610.4	O-ring (if sleeve fitted)
4610.5	O-ring
6570.6	Screw
6700.2	Key

Key drive design for 304/316 stainless steel and above. Secure screw with PTFE sealant (Loctite 577).

Drawings taken from B731/1644, sheet 2, rev -



### 8.4 Parts interchangeability

CPXV pump size	Bearing carrier	Casing gasket	Line bearing
40-25-125	1	1	1
50-32-125	1	1	1
65-40-125	1	1	1
80-50-125	1	1	1
100-80-125	1	1	1
32-20-160	1	2	1
40-25-160	1	2	1
50-32-160	1	2	1
65-40-160	1	2	1
80-50-160	1	2	1
100-65-160	2	2	2
125-100-160	2	2	2
32-20-200	1	3	1
40-25-200	1	3	1
50-32-200	1	3	1
65-40-200	1	3	1
80-50-200	1	3	1
100-65-200	2	3	2
125-100-200	2	3	2
40-25-250	2	4	2
50-32-250	2	4	2
65-40-250	2	4	2
80-50-250	2	4	2
100-65-250	2	4	2
50-32-315	2	5	2
65-40-315	2	5	2
80-50-315	2	5	2

### 8.5 General arrangement drawing

The typical general arrangement drawing and any specific drawings required by the contract will be sent to the Purchaser separately unless the contract specifically calls for these to be included into the User Instructions. If required, copies of other drawings sent separately to the Purchaser should be obtained from the Purchaser and retained with these User Instructions.

## 9 CERTIFICATION

Certificates determined from the Contract requirements are provided with these Instructions where applicable. Examples are certificates for CE marking, ATEX marking etc. If required, copies of other certificates sent separately to the Purchaser should be obtained from the Purchaser for retention with these User Instructions.

## 10 OTHER RELEVANT DOCUMENTATION AND MANUALS

### 10.1 Supplementary User Instruction manuals

Supplementary instruction determined from the contract requirements for inclusion into User Instructions such as for a driver, instrumentation, controller, sub-driver, seals, sealant system, mounting component etc. are included under this section. If further copies of these are required they should be obtained from the purchaser for retention with these User Instructions.

Where any pre-printed set of User Instructions are used, and satisfactory quality can be maintained only by avoiding copying these, they are included at the end of these User Instructions such as within a standard clear polymer software protection envelope.

### 10.2 Change notes

If any changes, agreed with Flowserve, are made to the product after its supply, a record of the details should be maintained with these User Instructions.

### 10.3 Additional sources of information

*Reference 1:*

NPSH for Rotodynamic Pumps: a reference guide, Europump Guide No. 1, Europump & World Pumps, Elsevier Science, United Kingdom, 1999.

*Reference 2:*

Pumping Manual, 9<sup>th</sup> edition, T.C. Dickenson, Elsevier Advanced Technology, United Kingdom, 1995.

*Reference 3:*

Pump Handbook, 2<sup>nd</sup> edition, Igor J. Karassik et al, McGraw-Hill Inc., New York, 1993.

*Reference 4:*

ANSI/HI 1.1-1.5. Centrifugal Pumps - Nomenclature, Definitions, Application and Operation.

*Reference 5:*

ANSI B31.3 - Process Piping.

*Reference 6:*

ESA – Guidelines for Safe Seal Usage (Flanges and Gaskets).



**Notes:**



Notes:

**Your Flowserve factory contact:**

Flowserve Pumps  
Flowserve GB Limited  
Lowfield Works, Balderton  
Newark, Notts NG24 3BU  
United Kingdom

Telephone (24 hours) +44 1636 494 600  
Sales & Admin Fax +44 1636 705 991  
Repair & Service Fax +44 1636 494 833  
Email: [newarksales@flowserve.com](mailto:newarksales@flowserve.com)

**Your local Flowserve representatives:****North America:**

Flowserve Pump Division  
3900 Cook Boulevard  
Chesapeake, VA 23323-1626, USA

Telephone +1 757 485 8000  
Customer Service Fax +1 457 485 8149

*To find your local Flowserve representative please  
use the Sales Support Locator System found at  
[www.flowserve.com](http://www.flowserve.com)*

**FLOWSERVE REGIONAL  
SALES OFFICES:****USA and Canada**

Flowserve Corporation  
5215 North O'Connor Blvd.,  
Suite 2300  
Irving, Texas 75039-5421, USA  
Telephone +1 937 890 5839

**Europe, Middle East, Africa**

Flowserve Corporation  
Parallelweg 13  
4878 AH Etten-Leur  
The Netherlands  
Telephone +31 76 502 8100

**Latin America and Caribbean**

Flowserve Corporation  
Martín Rodríguez 4460  
B1644CGN-Victoria-San Fernando  
Buenos Aires, Argentina  
Telephone +54 11 4006 8700  
Fax +54 11 4714 1610

**Asia Pacific**

Flowserve Pte. Ltd  
10 Tuas Loop  
Singapore 637345  
Telephone +65 6771 0600  
Fax +65 6862 2329