



# *USER INSTRUCTIONS*

## *Limitorque® L120-85 Actuator*

*FCD LMENIM1202-03-AQ – 06/15*

*Installation  
Operation  
Maintenance*



# Contents

<b>1</b>	<b>Introduction</b>	<b>4</b>	<b>6</b>	<b>Maintenance</b>	<b>28</b>
1.1	Purpose	4	6.1	Lubrication	28
1.2	User Safety	4	6.1.1	Initial Inspection	28
<b>2</b>	<b>Initial Inspection and Storage Instructions</b>	<b>5</b>	6.1.2	Frequency	28
2.1	Inspection and Recording	5	6.1.3	Routine Inspection	28
2.2	Short-Term Storage	5	6.1.4	Factory Lubricants	29
2.3	Product Identification	6	6.1.5	Minimum Lubricant Qualities Required	29
2.4	Product Description	7	<b>7</b>	<b>Disassembly</b>	<b>30</b>
2.5	Product Features	7	7.1	Removal From Valve	30
<b>3</b>	<b>Actuator Weight</b>	<b>8</b>	7.2	Open Electrical Compartment and Disconnect Motor	30
<b>4</b>	<b>Installation Instructions</b>	<b>9</b>	7.3	Remove Control Wiring	31
4.1	Actuator Mounting	9	7.4	Remove Limit and Torque Switch	31
4.1.1	Torque Only Applications (Drive 1)	10	7.5	Remove Motor Assembly	31
4.1.2	Torque and Thrust Applications (Drive 2)	10	7.6	Remove Handwheel	31
4.1.3	Mounting Bolts	11	7.7	Remove Handwheel Shaft Assembly	31
4.1.4	Stem Cover for Rising Stem Applications	11	7.8	Remove Declutch Lever Assembly	32
4.2	Verifying Motor Rotation Direction	13	7.9	Remove Clutch Assembly	32
4.2.1	Initial Electrical Connections	13	7.10	Remove Clutch Pinion Assembly	32
4.2.2	Motor rotation (phasing) and OPEN/CLOSE pushbutton operation.	14	7.11	Remove Worm Shaft Assembly	32
4.2.3	Three-Phase Motor	14	7.12	Remove and Disassemble Thrust Base	33
4.2.4	DC Motor	15	7.13	Remove Drive Sleeve	33
4.3	Limit Switch Settings	15	<b>8</b>	<b>Assembly</b>	<b>34</b>
4.3.1	Basic Theory of Operation	16	8.1	Handwheel Shaft Assembly and Shimming	34
4.3.2	Adjustment—General	17	8.2	Verifying Handwheel Operation	38
4.3.3	Setting the OPEN Limit Switch	17	8.3	Thrust Base Assembly and Shimming	38
4.3.4	Setting the CLOSE Limit Switch	19	<b>9</b>	<b>Troubleshooting</b>	<b>39</b>
4.4	Torque Switch Setting and Wiring	20	9.1	Typical Wiring Diagram	41
4.4.1	Basic Theory of Operation	20		Three-phase with Control Package	37
4.4.2	Setting the Torque Switch	20	<b>10</b>	<b>How to Order Parts</b>	<b>42</b>
4.4.3	Balancing the Torque Switch	21	10.1	L120-85 Illustrated Parts Breakdown	43
4.4.4	Rewiring the Torque Switch for Non-Standard Drive Sleeve Rotation	21	10.2	L120-85 Parts List	48
4.5	Position Indication	21	<b>11</b>	<b>Regulatory Information</b>	<b>50</b>
4.5.1	Local Position Indication	21			
4.5.2	Remote Position Indication	23			
4.5.3	Setting the Potentiometer	24			
<b>5</b>	<b>Operation</b>	<b>26</b>			
5.1	Description of Motor Operation	26			
5.2	Description of Manual Operation	26			
5.3	Electrical Start-up Procedure	27			

# Figures

Figure 1: Limitorque L120-85 Actuator	7
Figure 2: L120-85 Torque Drive Nut and Retaining Ring Details	10
Figure 3: Thrust Base removal from an L120-85	10
Figure 4: L120-85 Torque Drive Nut orientation (Drive 1)	12
Figure 5: L120-85 Thrust Base Assembly orientation (Drive 2)	12
Figure 6: Electrical Compartment and Conduit Pipe Plug openings	14
Figure 7: Grounding Lug location	14
Figure 8: Limit Switch Rotor development	15
Figure 9: L120-85 Limit Switch Components	17
Figure 10: Limit Switch OPEN/CLOSED Rotor Cam orientation	18
Figure 11: Torque Switch Components	20
Figure 12: Reversing Torque Switch wiring	21
Figure 13: Aligning MDPI Pointer for Fully CLOSED Position	21
Figure 14: Remote Position Indicator Calibration Configuration	24
Figure 15: Potentiometer Calibration configuration	24
Figure 16: Loosening Potentiometer Assembly	25
Figure 17: Removing Clutch Pinion Assembly	32
Figure 18: Key components affected by Handwheel shimming	34
Figure 19: Cut-away view of L120-85 actuator with Clutch Latch positioned on face of Clutch Bearing	35
Figure 20: Gap between Housing face and Handwheel Bushing shown as dimension "A"	35
Figure 21: Shimming parts and their order of assembly	37
Figure 22: Shim location for gap "B" dimension/	37
Figure 23 Three-phase with Control Package	41
Figure 24: Electrical Compartment	43
Figure 25: Motor and Motor Drive Components	44
Figure 26: Handwheel Shaft and Associated Components	45
Figure 27: Drive Sleeve Group	46
Figure 28: Thrust Base Group	47

# Tables

Table 1: L120-85 Approximate Weight Chart	8
Table 2: Torque Drive Nut: Maximum Allowable Bore and Key Sizes	10
Table 3: L120-85 Actuator/Mounting Base Tap Size	13
Table 4: Gap "A" shim thickness selection chart	36
Table 5: Gap "B" shim thickness selection chart	37

# 1

## Introduction

### 1.1 Purpose

This Installation and Maintenance Manual explains how to install and maintain the L120-85 actuator. Information is provided for installation, disassembly, reassembly, lubrication, and parts selection.

 **WARNING:** Read this installation and maintenance manual carefully and completely before storing, installing, operating or troubleshooting your Flowserve Limitorque actuator. Be aware of electrical hazards within the actuator and high-pressure hazards at the attached valve or other device when installing or performing maintenance on your L120-85 actuator.

### 1.2 User Safety

Safety notices in this manual detail precautions the user must take to reduce the risk of personal injury and damage to the equipment. The user must read and be familiar with these instructions before attempting installation, operation, or maintenance. Work should be performed by a qualified tradesman who is familiar with the operation and maintenance of electric actuators. Failure to observe these precautions could result in serious bodily injury, damage to the equipment, voiding of the warranty, or operational difficulty.

Safety notices are presented in this manual in three forms:

 **WARNING:** Refers to personal safety. Alerts the user to potential danger. Failure to follow warning notices could result in personal injury or death.

 **CAUTION:** Directs the user's attention to general precautions that, if not followed, could result in personal injury and/or equipment damage.

**NOTE:** Highlights information critical to the user's understanding of the actuator's installation and operation.

# 2

## Initial Inspection and Storage Instructions

### 2.1 Inspection and Recording

Upon receipt of the actuator, several steps should be initially followed to ensure condition of equipment and to establish proper record keeping.

1. Carefully remove the actuator from the shipping carton or skid. Thoroughly examine for any physical damage which may have occurred during shipment. If you note any damage, immediately report the damage to the transport company.
2. A nameplate with important information is attached to each actuator. Record this information for future reference.

### 2.2 Short-Term Storage (less than one year)

Actuators are not weatherproof until properly installed on the valve or prepared for storage.

Store actuators in a clean, dry, protected warehouse away from excessive vibration and rapid temperature changes. If the actuators must be stored outside, they must be stored off the ground, high enough to prevent them from being immersed in water or buried by snow.

1. Position the actuator in storage with motor and switch compartment horizontal.
2. Connect the internal heaters (if supplied) or place desiccant in the switch compartment.
3. Replace all plastic caps or plugs with taped or doped pipe plugs and ensure that all covers are tight.
4. If the actuator is mounted on a valve and the stem protrudes from the actuator, a suitable stem cover must be provided.

## 2.3 Product Identification

The actuator nameplate is located on the back of the actuator, opposite the limit switch compartment.

The nameplate contains the following information:

- Product name
- Point of Manufacture
- Order Number
- Serial Number
- Customer Tagging
- Certification Information

The motor nameplate is located on the motor. The nameplate contains the following information:

- ID Number
- Run Torque
- RPM
- Full Load Amps
- Insulation Class
- Horsepower
- Number of Phases
- Motor Code
- Connection Diagram
- Start Torque
- Enclosure Type
- Volts
- Locked Rotor Amps
- Duty Rating
- Service Factor
- Frequency
- Ambient Temperature

Figure 1: Limitorque L120-85 Actuator

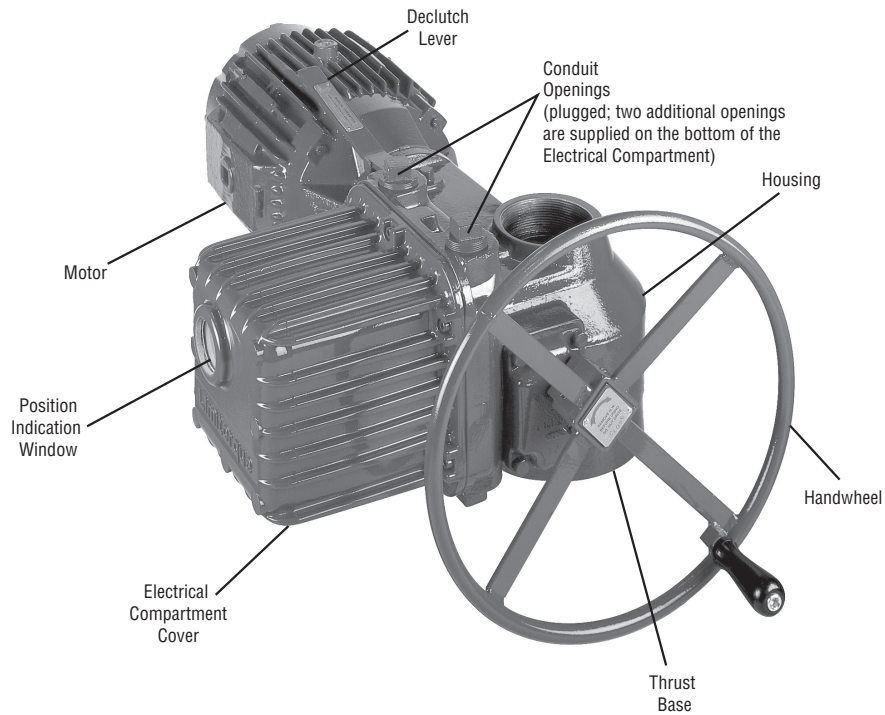

## 2.4 Product Description

Your L120-85 actuator controls the opening and closing travel of valves or other actuated devices. OPEN and CLOSED limits of travel are controlled by limit switches, and output torque is controlled by the Torque Switches. As a result, all valves and other actuated devices are protected from potential damage from overload, improper seating and foreign obstructions.

Limitorque actuators may be mounted on any appropriately sized valve in almost any position or location.

Microprocessor-based controls and monitoring devices are also available for L120 actuators. Contact your local Limitorque distributor or Limitorque sales office for further information.

## 2.5 Product Features

- Up to 850 ft-lb/1156 Nm torque capacity.
- Up to 45,000 lb./20250 kg thrust capacity.
- Up to 3.25"/76 mm threaded stem capacity.
- Up to 2.75"/70 mm bore capacity.
- Torque Only (Drive 1) or Torque and Thrust (Drive 2) actuators, with removable ductile iron thrust base assembly.
- Cast iron gear housing.
- All power gearing supported on anti-friction bearings.
- All gearing is alloy, heat-treated steel or bronze.
- Speed range of 24-192 RPM (60 Hz), 20-160 RPM (50 Hz).
- Declutch force independent of load on valve stem.
- Self-locking gearing available.

# 3

## Actuator Weight

The following table is an L120-85 representative weight chart. It provides the weight of several components that may be incorporated into a typical package. Use the chart as a guideline to estimate the weight of your particular actuator package.

*Table 1: L120-85 Approximate Weight Chart*

Components	lb.	kg
L120-85 with 40 ft-lb 1700 RPM Motor (Torque only)	275	125
With Minimum Integral Control Package and Compartment	315	143
Thrust Base Assembly (Drive 2) <sup>1</sup>	70	32

<sup>1</sup> Add to weights shown above for basic actuator or basic actuator with integral control package.



# 4

## Installation Instructions

**WARNING:** Read this Installation and Maintenance Manual carefully and completely before attempting to store, install, operate or troubleshoot your Limitorque valve actuator. Be aware of electrical hazards within the actuator and high pressure hazards of the attached valve or other actuated device when installing or performing maintenance on your L120-85 actuator.

**NOTE:** If your actuator incorporates a rising stem application, it may be shipped with a plastic cap over the Drive Sleeve Housing. If so, in order to store without possible corrosion occurring, install a pipe plug or protective stem cover to protect the Drive Sleeve Housing.

**NOTE:** Failure to comply with recommended storage procedures could cause the warranty to be voided. For long-term storage procedures, consult the Limitorque Customer Service Department.

### 4.1 Actuator Mounting

Your L120-85 is designed to perform actuation for torque only applications (drive 1) or for torque and thrust applications (drive 2). If you are using a torque only configuration, before installing on the valve or other actuated device, you will need to verify that the Torque Drive Nut (piece 95) is properly bored and keyed to fit your valve stem. If you are using a torque and thrust configuration, you will need to verify that the Thrust Base Drive Sleeve (piece 101) is properly threaded to fit your threaded valve stem. Use the following procedures to check for proper fit of the Torque Drive Nut or the Thrust Base Drive Sleeve.

### 4.1.1 Torque Only Applications (Drive 1) (Refer to Figure 27)

Remove the Torque Nut Retaining Ring (piece 98) and Torque Drive Nut (piece 95) from actuator.

Figure 2: L120-85 Torque Drive Nut and Retaining Ring Details

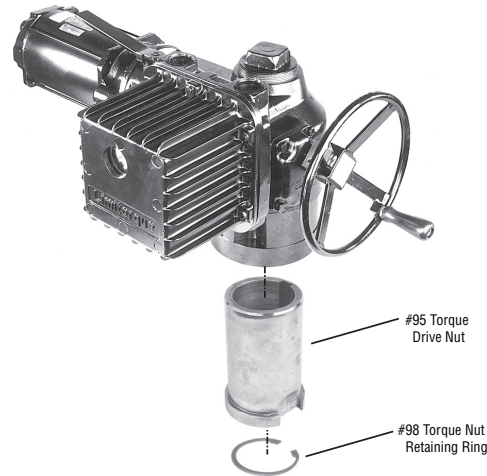

- A) If Torque Drive Nut has been bored and keywayed by supplier, verify dimensions of keyway for proper compatibility with the valve stem.
- B) If Torque Drive Nut has not been bored and keywayed by supplier, it is provided solid (blank) to allow customer to custom bore and key up to the maximum permissible sizes as listed:

Table 2: Torque Drive Nut: Maximum Allowable Bore and Key Sizes

Key Type	Maximum Bore in. (mm)	Maximum Key in. (mm)
Rectangle	2.750 (69.85)	.625 x .4375 (20 x 12)
Square	2.625 (66.67)	.625 x .625 (20 x 20)

### 4.1.2 Torque and Thrust Applications (Drive 2) (Refer to Figure 28)

Remove Socket Head Cap Screw (piece 110) and Lockwasher (piece 111) that holds the Thrust Base Housing Assembly to the actuator Housing (piece 1).

Figure 3: Thrust Base removal from an L120-85

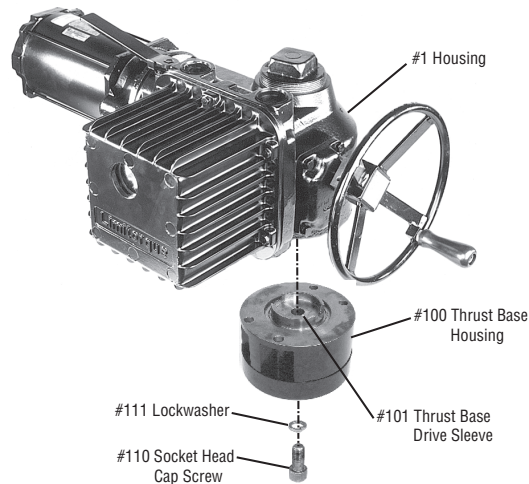

- A) If the Thrust Base Drive Sleeve (piece 101) has been threaded by supplier, verify thread compatibility with the threaded Valve Stem by screwing Drive Sleeve onto the valve stem.
- B) If Thrust Base Drive Sleeve (piece 101) has not been threaded by supplier, it is provided solid (blank) to allow customer to custom thread. Maximum threaded stem diameter is 3.25” (82.5 mm).

**NOTE:** If Thrust Base disassembly is required in order to thread blank Thrust Base Drive Sleeve, remove Quad Rings (piece 107) before removing Thrust Washer (piece 104) and Thrust Bearing (piece 103). This will prevent damaging the Quad Rings (piece 107). For details refer to Section 10.1, Figure 28.

### 4.1.3 Mounting Bolts

Mount the L120-85 actuator on the Actuator Mounting Adapter (Drive 1) or on the Thrust Base Assembly (Drive 2). High-strength (minimum hex head SAE-Grade 5 or ISO Metric Class socket head cap screws) 8.8 hex head or socket head cap screws with lockwashers are recommended. The quantity and thread size of the actuator mounting taps are as follows:

Table 3: L120-85 Actuator/Mounting Base Tap Size

Unit Type	Quantity	Tap Size
Drive 1 and 2		
English	4	3/4-10 Tap x 1.0 in. Deep*
Metric	4	M20 x 2.5 mm x 10 mm Deep*

\*Complies with F16 IOS mounting flange criteria

**NOTE:** Limitorque has supplied four taps for the L120-85 English and metric actuators. All four securing bolts are required to retain torque and/or thrust reaction on these actuators.

### 4.1.4 Stem Cover for Rising Stem Applications

- ▲ **CAUTION:** Selection and installation of a stem cover which is too short will result in damage to the valve and/or actuator.
- ▲ **CAUTION:** Be sure to complete each step of the installation overview before electrically operating your actuator. If your actuator is already mounted to a valve or other actuated device from the manufacturer, verify that the actuator is mounted according to the following overview. Failure to follow the installation procedures could result in personal injury or may allow the actuator to operate improperly and could cause damage to your equipment.
- ▲ **CAUTION:** Ensure Retaining Ring (piece 98) is properly engaged in the Drive Sleeve (piece 25) to secure the Torque Drive Nut (piece 95) in place. If the Torque Drive Nut is not properly secured, it may fall from the bottom of the actuator when removed from customer mounting adapters.

Before putting your actuator into operational service, check the height of your valve stem at the full OPEN position and mount a suitable stem cover to protect the valve stems and to prevent water entry into the actuator.

#### Installation Overview

##### 1. Applications

###### A. Torque Only Applications (Drive 1)

Mount Torque Drive Nut (piece 95) in the actuator with the Torque Drive Nut axially aligned on the Drive Sleeve (piece 25) so that the bottom of the nut is positioned inside the actuator Mounting Base. Secure Torque Drive Nut inside Drive Sleeve (piece 25) with Retaining Ring (piece 98). Refer to Figure 27.

**B. Torque and Thrust Applications (Drive 2)**

Screw the Thrust Base Assembly onto the Threaded Valve Stem and secure the Thrust Base Assembly to the Actuator Mounting Base using Socket Head Cap Screws (piece 110) and Lockwashers (piece 111).

Figure 4: L120-85 Torque Drive Nut orientation (Drive 1)

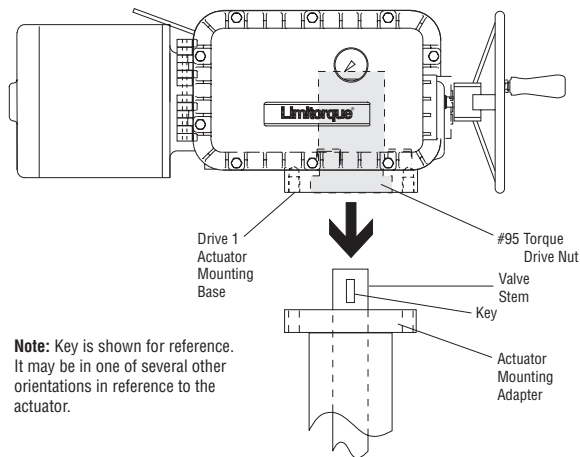
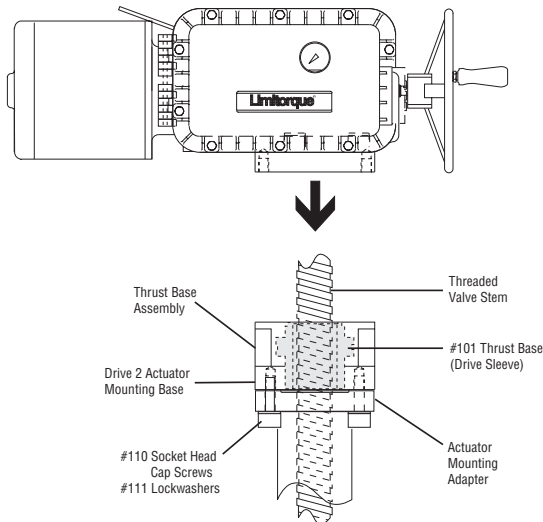

Figure 5: L120-85 Thrust Base Assembly orientation (Drive 2)



## 4.2 Verifying Motor Rotation Direction

### 4.2.1 Initial Electrical Connections

**⚠ WARNING: Hazardous Voltage.** No electrical power should be connected until all wiring and Limit Switch adjustments have been completed. Once power is supplied to actuator, exercise caution if cover is not installed.

1. Open the Electrical Compartment Cover (piece 200-1) and remove the Conduit Pipe Plugs from the opening(s) most conveniently located for your power leads and other cabling.

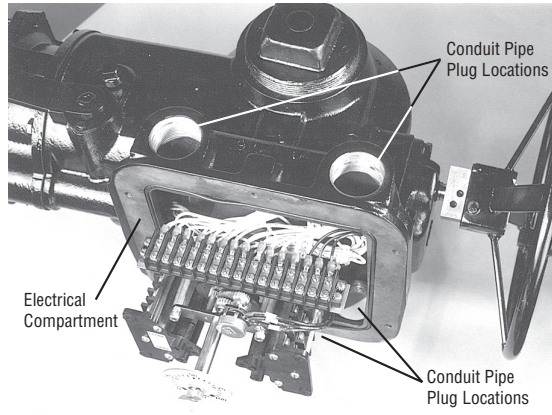

Figure 6: Electrical Compartment and Conduit Pipe Plug openings

2. Adjust the Limit Switches, MDPI (Mechanical Dial Position Indicator) and Potentiometer following the procedures outlined in Sections 4.5 and 4.7.
3. Ensure Torque Switch is set properly for your application. In most cases, adjustments are not needed, but if changes are required, see Section 4.6, “Torque Switch Settings and Wiring”.
4. Connect wiring to Terminal Strips provided on the actuator. Refer to the wiring diagram supplied with your specific actuator. “Fork-type” terminal connections are recommended.
5. Be sure any unused conduit entrances are plugged with metal Conduit Pipe Plugs.

**Notes:**

- a) Explosion-proof actuators require approved “sealing fittings” installed in accordance with the National Electric Code.
- b) Submersible actuators require approved “sealing fittings” in order to prevent water entering the actuator.

6. Attach grounding wire to Grounding Lug (piece 14).

Figure 7: Grounding Lug location

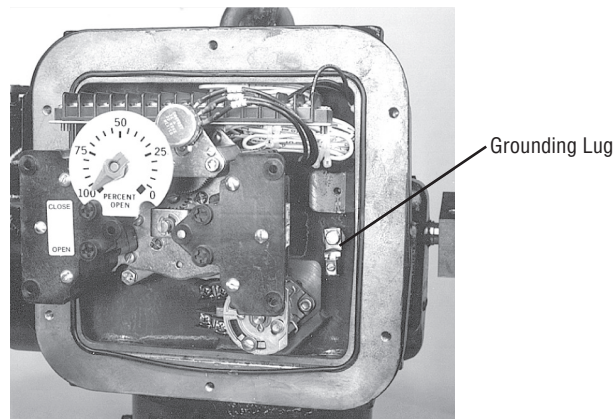

7. Inspect actuator for proper lubrication. Refer to “Lubrication” Section 6.1 for lubrication instructions.
8. Verify that Motor rotation is operating in the proper direction; the Motor rotation will have a direct impact on the Limit Switch and Torque Switch functions. Follow the procedure “Verifying Motor Rotation Direction” in Sections 4.4.2, 4.4.3 and 4.4.4).
9. Close Electrical Compartment Cover (piece 200-1).
10. The actuator is now ready for electrical operation. Continue to “Electrical Start-up Procedure” in Section 5.3.

## 4.2.2 Motor rotation (phasing) and OPEN/CLOSE Pushbutton Operation

It is very important to check for correct motor rotation to ensure that serious damage to your valve or other equipment does not occur. If the actuator motor rotates in the wrong direction, damage could occur by over-torquing equipment into a seated position.

Prior to being shipped from the factory, each actuator is inspected to verify proper operation of the Torque and position Limit Switch and to ensure that they function correctly (i.e. closes when the CLOSE pushbutton is depressed, opens with the OPEN pushbutton, etc.). These inspections are made with a properly phased power source connected as described in the actuator manual.

**▲ CAUTION:** To ensure proper operation and to prevent your actuator or other actuated equipment from damage, verify that your actuator is properly connected to its power source.

**NOTE:** Your application may vary from the following standard wiring configurations for Three-phase, Single-phase and DC motors. Refer to your actuator wiring diagram for user-specific wiring configuration.

## 4.2.3 Three-Phase Motor

1. Using the Handwheel, move the valve to a midtravel position (midtravel position allows electrical operation in the valve “safe” area and keeps the OPEN and CLOSED Limit Switches from tripping while testing motor direction).
2. Be prepared to immediately remove power should the actuator run the wrong way.
3. Test motor direction by momentarily pressing the OPEN pushbutton:
  - A) If the actuator moves toward CLOSED, immediately turn all power OFF and reverse the motor leads T1 and T3.
 

**NOTE:** Refer to your actuator wiring diagram for user-specific wiring configuration.
  - B) If the actuator moves toward OPEN, the motor is wired properly for the application.

## 4.2.4 DC Motor

1. Using the Handwheel, move the valve to a midtravel position (midtravel position allows electrical operation in the valve “safe” area and keeps the OPEN and CLOSED limit switches from tripping while testing motor direction).
2. Test the motor direction by momentarily pressing the OPEN pushbutton:
  - A) If the actuator moves toward CLOSED, immediately turn all power OFF and reverse the motor leads A1 and A2.
 

**NOTE:** Refer to your actuator wiring diagram for user specific wiring configuration.
  - B) If the actuator moves toward OPEN, the motor is wired properly for the application.

### 4.3 Limit Switch Settings

The standard L120-85 Limit Switch has 16 contacts. The OPEN/CLOSE Limit Switch (first eight contacts) has two Rotor Sets, one for the OPEN position and one for the CLOSED position. Each Rotor Set has four electrical contacts which can be arranged in any combination of normally OPEN and normally CLOSED. The SPARE Limit Switch (second eight contacts) has two additional Rotor Sets with four contacts each that can be set to operate anywhere between the OPEN and CLOSE positions. These can be used to stop the valve in mid-travel or to interlock with other equipment such as pumps, fans, mixers, etc. Refer to Figure 8.

Figure 8: Limit Switch Rotor Development

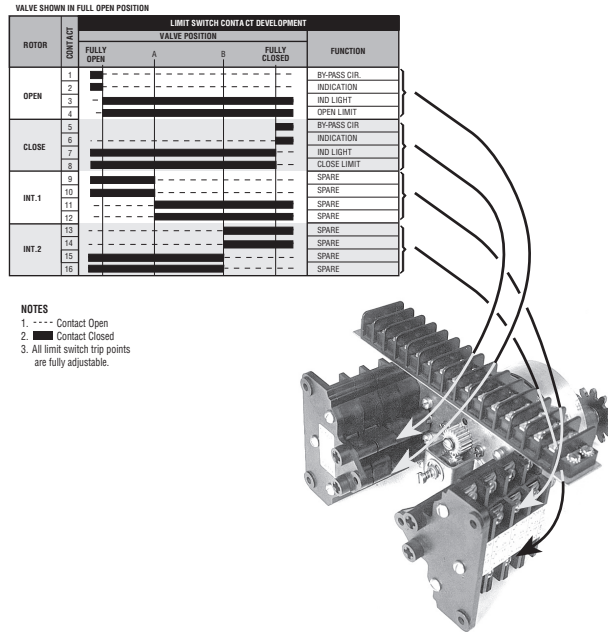

**NOTE:** THE LIMIT SWITCH IS NOT PRESET at the Limitorque factory, and must be set after mounting on the valve or other associated equipment. If your L120-85 actuator has been shipped already installed on your equipment, your actuator should have the Limit Switch set for your application. If your actuator is not already installed on your equipment or needs resetting, use the following instructions to make the appropriate settings.

The following instructions for setting the Limit Switches are based on the typical orientation for most actuator applications (CCW ↺ to OPEN and CW ↻ to CLOSE). Consult the applicable wiring diagram located in the actuator Electrical Compartment for your specific Limit Switch development.

#### 4.3.1 Basic Theory of Operation

**⚠ WARNING:** Do not manually operate actuator with devices other than installed Handwheel and Declutch Lever. Using additive force devices (cheater bars, wheel wrenches, pipe wrenches or other devices of this nature) on the actuator Handwheel or Declutch Lever may cause serious personal injury and/or damage to the actuator or valve.

**⚠ WARNING:** Hazardous Voltage. Make sure all power is OFF before opening the Electrical Compartment Cover or making the following settings.

The Limit Switch (piece 305) is driven directly by the Worm Shaft through the Limit Switch Pinion. Therefore, the Limit Switch is directly connected to the output of the actuator. Once the Limit Switch is properly set, it measures the position of the valve, or other equipment, in the ELECTRIC or MANUAL operating modes.



The OPEN Rotor consists of contacts 1 through 4. These switches are set to change state at the full OPEN position. The switch functions are as follows:

**Contact 1** is the CLOSED Torque Switch bypass circuit. It's purpose is to allow the electric actuator to apply its full torque to unseat a backseated valve. When a valve is manually backseated to prevent packing leakage, it may stick momentarily when first operated. To prevent the CLOSE Torque Switch from stopping the actuator during unseating, this momentary bypass is applied. The OPEN Rotor actuates at the full OPEN position causing contact 1 to open as soon as the valve moves in the close direction, thus returning the Torque Switch function to the control circuit.

**Contact 2** is normally used for a Remote Valve Position Indication Lamp. As shown in Figure 8, the lamp will be turned ON when the valve reaches the full OPEN position.

**Contact 3** is for the Local Position Indication Lamp; included as part of the actuator assembly when required. This switch turns the green lamp/LED OFF in the full OPEN position, leaving the red lamp/LED energized and indicating that the valve is OPEN.

**Contact 4** is the OPEN Limit Switch which opens the control circuit to de-energize the Motor at full OPEN position.

The CLOSE Rotor consists of contacts 5 through 8. This Rotor is set to change state at the full CLOSE position. Switch functions are as follows:

**Contact 5** is the OPEN Torque Switch bypass. After the valve has been tightly closed, it may stick when it is first opened which would cause the Torque Switch Contacts to break. To momentarily overcome this sticking, the OPEN Torque Switch is bypassed. This OPEN Torque Switch bypass is part of the closed valve position rotor so that as soon as the valve moves in the OPEN direction, the bypass contact opens and the OPEN Torque Switch control function is returned.

**Contact 6** is normally used for a Remote Valve Position Indication Lamp. As shown in Figure 8, the lamp will be turned ON when the valve reaches the full CLOSE position.

**Contact 7** is for the Local Position Indication Lamp; included as part of the actuator assembly when required. This switch turns the red lamp/LED OFF in the full CLOSE position, leaving the green lamp/LED energized and indicating the valve is in the full CLOSE position.

**Contact 8** is the CLOSE Limit Switch that opens the control circuit to de-energize the Motor at full CLOSE position.

## 4.3.2 Adjustment—General

### Tools required:

- The cross-slotted Intermediate Shafts A, B, C and D have been designed for use with a 6" No. 2 Phillips screw driver shank chucked into a variable speed reversible electric drill. (See figure 9 for Limit Switch components).
- Phillips Head or Flat Head screwdriver.

 **WARNING:** Potential Explosion Hazard. Do not use an electric drill for setting the Limit Switch in an explosive environment.

 **CAUTION:** When setting Limit Switch Rotor Cams using a variable speed reversible electric drill, Do Not run drill at speeds higher than 200 RPM. Operating drill at high speeds can cause damage to gearing within the Limit Switch.



**▲ CAUTION:** The Worm on the Worm Shaft Assembly is available in two different ratios 19:1 and 38:1. To avoid damage to the gearing mechanisms, be sure you change the Limit Switch Drive Pinion gear if the Worm gear ratio is changed.

**NOTE:** The Limit Switch is available with a 4 Gear Set or a 5 Gear Set within the Gear Frame Assembly. The number of Gear Sets built into your specific Limit Switch will determine the number of maximum Drive Sleeve rotations required to go the full range of the Limit Switch. A four Gear Set with 19:1 and 38:1 has a maximum rotation of 902.25 Drive Sleeve rotations. A five Gear Set with 19:1 and 38:1 has a maximum rotation of 9022.5 Drive Sleeve rotations.

Figure 9: L120-85 Limit Switch Components

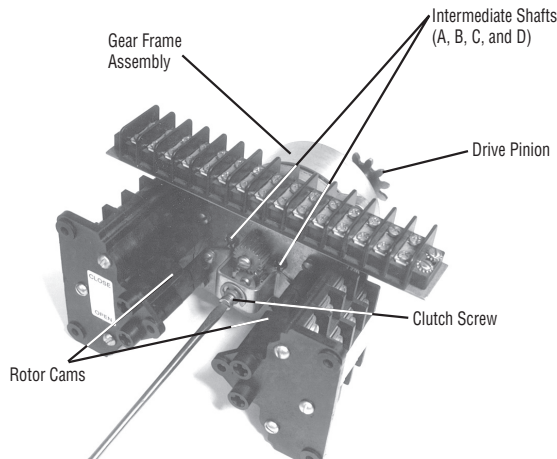

### 4.3.3 Setting the OPEN Limit Switch

1. De-energize the electrical circuit to the actuator.
2. Open the Electrical Compartment Cover (piece 200-1).
3. Put the actuator into MANUAL operation by moving the Declutch Lever in the direction of the arrow on the lever until the Declutch Lever locks in place.
4. Turn the Handwheel CCW ↺ to move the valve to the full OPEN position. While turning the Handwheel, note the direction of the Intermediate Shaft that corresponds to the Open Rotor Group. See figure 9.

**NOTE:** Most applications require turning the Handwheel CW ↻ to obtain the full CLOSE position and CCW ↺ to obtain full OPEN position. The actuator Drive Sleeve rotates in a CW ↻ direction to the CLOSE position and CCW ↺ to the OPEN position. The Limit Switch Intermediate Shafts rotate in a CCW ↺ direction to the CLOSE position and CW ↻ to the OPEN position. If your application is configured differently, keep in mind that the descriptions in this manual will describe rotation directions opposite of your application.

5. Once the valve is fully OPEN, turn the Handwheel back toward CLOSE approximately one full turn. This will allow for coasting during motor operation.

**▲ CAUTION:** Do not operate the actuator when the Clutch Screw is in a fully depressed position; loss of the contact setting will occur and the Setting Rod will be damaged.

- ▲ **CAUTION:** For highly geared actuators, one turn of the handwheel may not be sufficient to allow for coast of moving parts. Refer to valve manufacturer setting requirements in these cases.
- 6. Push in Clutch Screw and turn CW ↻ one quarter turn to latch in a depressed position.
- 7. Limit Switch Rotor Cams
  - A. If your Limit Switch Rotor Cams did not trip at the full OPEN position point, turn the Intermediate Open Shaft in a CW ↻ direction until the Open Limit Rotor Cam rotates 90° to make an OPEN contact (OPEN limit trip point = Rotor Cam in a vertical orientation to make an OPEN contact); see figure 10 for orientation. Once you have reached the full OPEN position point, use the Handwheel to rotate the Intermediate Shaft slowly in the CCW ↻ direction until the Rotor just trips again.
  - B. If your Limit Switch Rotor Cams did trip before reaching the full OPEN position point, leave the valve at the full OPEN position point and turn the Intermediate Open Shaft in a CCW ↻ direction until the Rotor Cam rotates 90° to make an OPEN contact (OPEN limit trip point = Rotor Cam in a vertical orientation to make an OPEN contact). Once you have reached the full OPEN position point, rotate the Intermediate Shaft slowly in the CW ↻ direction until the Rotor just trips again.



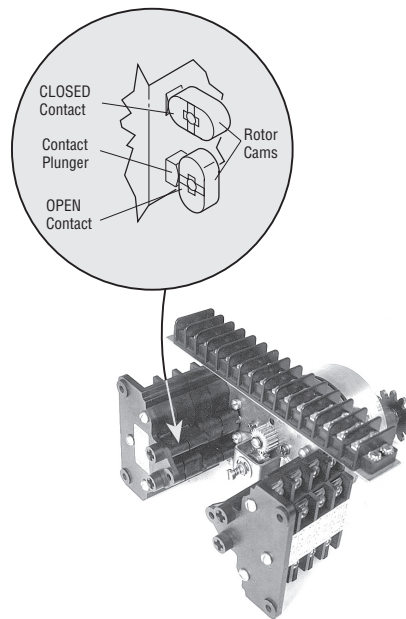



Figure 10: Limit Switch OPEN/CLOSED Rotor Cam orientation



- 8. Before operating the actuator, depress and turn the Clutch Screw CCW ↻ one-quarter turn to the spring release position. Insert a screwdriver into each of the Intermediate Shafts and “rock” them CW ↻ and CCW ↻ a few times to ensure all the gearing is seated well.

#### 4.3.4 Setting the CLOSE Limit Switch

1. De-energize the electrical circuit to the actuator.
2. Open the Electrical Compartment Cover (piece 200-1).
3. Put the actuator into MANUAL operation by moving the Declutch Lever in the direction of the arrow on the lever until the Declutch Lever locks in place.
4. Turn the Handwheel CW ↻ to move the valve to the full CLOSED position. While turning the Handwheel, note the direction of the Intermediate Shaft that corresponds to the Closed Rotor Group.

**NOTE:** Most applications require turning the Handwheel CW  to obtain the full CLOSE position and CCW  to obtain full OPEN position. The actuator Drive Sleeve rotates in a CW  direction to the CLOSE position and CCW  to the OPEN position. The Limit Switch Intermediate Shafts rotate in a CCW  direction to the CLOSE position and CW  to the OPEN position. If your application is configured differently, keep in mind that the descriptions in this manual will describe rotation directions opposite of your application.



5. Once the valve is fully CLOSED, turn the Handwheel back toward OPEN approximately one full turn. This will allow for coasting during motor operation.



**▲ CAUTION:** Do not operate the actuator when the Clutch Screw is in a fully depressed position; loss of the contact setting will occur and the Setting Rod will be damaged.



**▲ CAUTION:** For highly geared actuators, one turn of the handwheel may not be sufficient to allow for coast of moving parts. Refer to valve manufacturer setting requirements in these cases.

6. Push in Clutch Screw and turn CW  one-quarter turn to latch in a depressed position. See Figure 9 for Limit Switch nomenclature.

7. Limit Switch Rotor Cams

- A. If your Limit Switch Rotor Cams did not trip at the full CLOSE position point, turn the Intermediate Close Shaft in a CCW  direction until the Close Limit Rotor Cam rotates 90° to make an OPEN contact (CLOSE limit trip point = Rotor Cam in a vertical orientation to make an OPEN contact). Once you have reached the full CLOSED position point, rotate the Intermediate Shaft slowly in the CW  direction until the Rotor just trips again.

- B. If your Limit Switch Rotor Cams did trip before reaching the full CLOSE position point, leave the valve at the full CLOSE position point and turn the Intermediate Close Shaft in a CW  direction until the Close Limit Rotor Cam rotates 90° to make an OPEN contact (CLOSE limit trip point = Rotor Cam in a vertical orientation to make an OPEN contact). Once you have reached the full CLOSE position point, rotate the Intermediate Shaft slowly in the CCW  direction until the Rotor just trips again.

8. Before operating the actuator, depress and turn the Clutch Screw CCW  one quarter turn to the spring release position. Insert a screwdriver into the Intermediate Shafts and “rock” them CW  and CCW  a few times to ensure all the gearing is seated well.

## 4.4 Torque Switch Setting and Wiring

**⚠ WARNING:** Hazardous Voltage. Turn the power OFF before opening the Electrical Compartment Cover or making any adjustments to the Torque Switch.

**NOTE:** Removal or modification of the Torque Switch Limiter Plate will void the actuator warranty. Do not exceed the torque setting indicated by the Torque Switch Limiter Plate without contacting the Limitorque Customer Service Department.

The L120-85 actuator is equipped with a double-acting Torque Switch that has been factory preset according to the required torque value provided by the valve manufacturer or other associated equipment supplier. Further Torque Switch adjustment should not be required; however, the Torque Switch may be reset from positions 1 through 5 (5 being the highest input torque requirement) by adjusting the Torque Switch Adjustment Screws unless it is limited by the Limiter Plate. See figure 11 for Torque Switch nomenclature.

### 4.4.1 Basic Theory of Operation

As torque is developed by the actuator, the Worm moves axially and causes compression on the Spring Pack Assembly (components of the Worm Shaft Assembly (piece 15)). The Spring Pack Assembly is calibrated so that a given amount of spring compression equates to a given amount of output torque. Axial Worm Shaft Assembly movement causes the Torque Switch Shaft (piece 300-13) to move, therefore engaging the Torque Switch measurement device. Once the Torque Switch is properly set, it measures valve, or other equipment, torque input in the ELECTRIC or MANUAL operating modes.

### 4.4.2 Setting the Torque Switch

**▲ CAUTION:** Installing or adjusting the Torque Switch with the actuator in a loaded condition will result in loss of torque protection. Before adjusting or installing the Torque Switch, place the actuator in MANUAL mode and turn the Handwheel in the direction necessary to release the torque load on the Worm Shaft Assembly.

**NOTE:** If Torque Switch replacement is required, be sure to use an L120-85 Torque Switch rather than replacing with an L120-10 thru 40 Torque Switch. The L120-85 Torque Switch Torque Arm is rotated 10° from the position of the Torque Arm on the L120-10 thru 40 Torque Switch (the red dot on the Torque Switch Shaft indicates an L120-85 Torque Switch).

Figure 11: Torque Switch Components

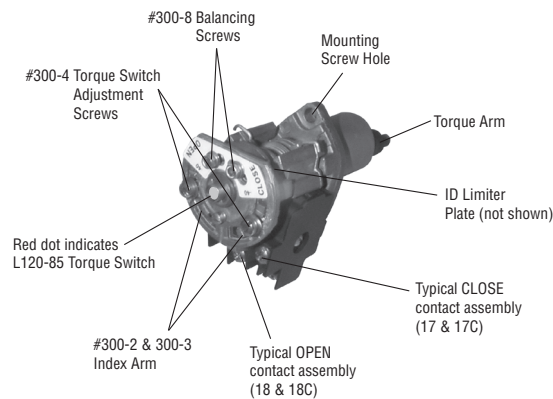

1. Turn all power to the actuator OFF.
2. Loosen the Torque Switch Adjustment Screws (piece 300-4) on the OPEN or CLOSED side of the Torque Switch.
3. Move Index Arm (piece 300-2 or piece 300-3) to desired torque setting. The higher number indicates an increased torque and/or thrust output requirement.
4. Tighten the Torque Switch Adjustment Screws (piece 300-4).
5. Turn power ON and operate the valve electrically to seat the valve or other device and to ensure tight shut-off.

### 4.4.3 Balancing the Torque Switch

If the Torque Switch has been removed from the actuator or if you are installing a new Torque Switch, it must be rebalanced using the following procedure:

1. Ensure that the actuator is in MANUAL mode and the load is removed from the Worm Shaft Assembly.
2. Make note of the current OPEN and CLOSED Torque Switch settings before reinstalling the Torque Switch.
3. Loosen Torque Switch Adjustment Screws (piece 300-4) and position both Index Arms (piece 300-2) and (piece 300-3) at the 1 setting; tighten the Torque Switch Adjustment Screws. Make sure the Index Marks are aligned. See figure 15.
4. Loosen Balancing Screws (piece 300-8) and install the Torque Switch. When properly installed, the base of the Torque Switch is flush against the Actuator Compartment and the hole for the Mounting Screw is aligned. Install the Mounting Screw.
5. Tighten the Balancing Screws. The Torque Switch is now balanced and ready for Index Arm (piece 300-2 and piece 300-3) to be returned to their original settings.
6. Follow your wiring diagram to connect Torque Switch wiring.

#### 4.4.4 Rewiring the Torque Switch for Non-Standard Drive Sleeve Rotation

**▲ CAUTION:** Double check your wiring diagram to verify that your Torque Switch is wired appropriately for your application. The Torque Switch will not protect your valve from over-torque if you do not apply appropriate wiring for your application.

L120-85 actuators are typically supplied with a CCW ↺ Drive Sleeve rotation to open a valve. The two Torque Switches are marked OPEN (CCW ↺) and CLOSE (CW ↻) based upon CCW ↺ Drive Sleeve rotation to open the valve. The MDPI on the L120-85 is typically mounted for the full CCW ↺ rotation to indicate the OPEN position (100%). If opposite drive sleeve rotation is required (CCW ↺ to CLOSE a valve), the following torque switch modifications are required.

**☠ WARNING:** Hazardous Voltage. Turn power OFF before opening the Electrical Compartment Cover or making any adjustments to the Torque Switch.

1. Turn power to the actuator OFF before changing Torque Switch wiring.
2. Reverse the OPEN and CLOSE Torque Switch labels on the ID Limiter Plate. See figure 11.
3. Interchange OPEN Torque Switch wires 18 and 18C with CLOSED wires 17 and 17C (refer to your wiring diagram for other Torque Switch wiring configurations).

Figure 12: Reversing Torque Switch Wiring

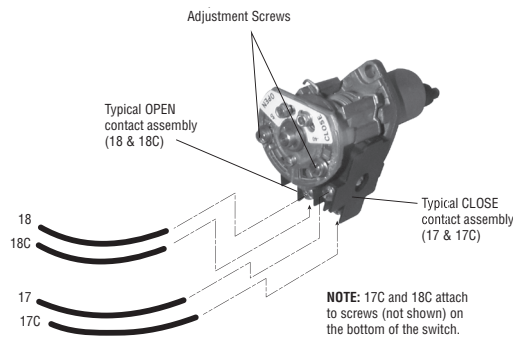

4. Remove the Mechanical Dial Position Indicator Plate and flip over for indication of CCW ↶ rotation to the valve's CLOSED position. See figure 13 for MDPI Dial Plate.
5. Reverse the OPEN/CLOSE directional arrow on the Handwheel.

## 4.5 Position Indication

The MDPI is used to indicate the current position of the valve or other actuated devices. Adjustments must be done after mounting the actuator on the application. If your supplier has not set the MDPI or your application has changed and requires resetting, use the following procedure to complete the MDPI settings.

**⚠ WARNING:** Hazardous Voltage. Turn power OFF before opening the Electrical Compartment Cover, calibrating the MDPI or installing the Remote Voltmeter Indicator.

### 4.5.1 Local Position Indication

1. Turn OFF all power to the actuator.
2. Manually position the valve in the fully CLOSED position.
3. Loosen the Round Head Machine Screw (piece 523) on the MDPI Pointer (piece 522).

Figure 13: Aligning MDPI Pointer for Fully CLOSED Position

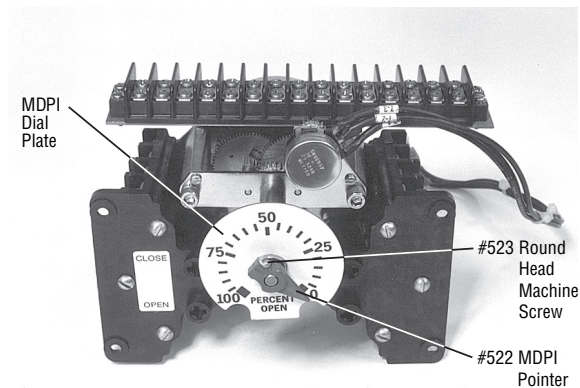

4. Move the MDPI Pointer to the (CLOSED) position.
 

**NOTE:** If your application uses CW ↷ Handwheel rotation to OPEN, flip the MDPI Plate over to properly orient the OPEN and CLOSED position on the MDPI Plate.
5. Tighten the Round Head Machine Screw on the MDPI Pointer.

### 4.5.2 Remote Position Indication

**⚠ WARNING:** Hazardous Voltage. Use extreme caution if the power is ON and Electrical Compartment Cover is open or removed.

**NOTE:** Typical voltmeter remote indicators furnished by Limitorque are built to accept a maximum of 10 volts. In order to make voltmeter adjustments, you will need a separate voltmeter with a scale suitable for the maximum incoming control voltage.

1. Mount the Adjustable Resistor as close as possible to the Remote Voltmeter Indicator.
2. Turn power to the actuator OFF and connect all wiring as shown in Figure 14. For now, connect the wires leading to the Remote Voltmeter Indicator to your test meter so you can conduct voltage readings during the setup.
3. Move the Adjustable Resistor Slider to the extreme opposite end of the Resistor from the Power Connection.
4. Open the Electrical Compartment Cover (piece 200-1). Loosen the Hex Head Retaining Nut at the base of the Potentiometer Bracket and dis-engage the Spur Gear from the Potentiometer Drive Gear. This will allow manual rotation of the Potentiometer Assembly. See figure 14.
5. Manually position the valve in the fully CLOSED position. As you are rotating the Handwheel to the CLOSED position, notice the direction the Potentiometer Spur Gear would be turning the Potentiometer Shaft/Wiper Arm inside the Potentiometer.
6. When the valve is CLOSED, turn the Potentiometer Shaft to the end-of-travel position that corresponds to the CLOSED position of the Potentiometer. Carefully reposition the Potentiometer Spur Gear onto the Potentiometer Shaft to re-engage with the gear train. Re-tighten Hex Head Retaining Nut at the base of the Potentiometer Bracket.
7. Turn power to the actuator ON. Your Test Meter should read “0” or almost “0”. If not, go back through the above steps 1–7 to get your Potentiometer calibrated to the proper end-of-travel.
8. Now manually position the valve in the fully OPEN position.
9. Move the Adjustable Resistor Slider toward the Power Connection end until the Test Meter reads 10 volts.
10. Turn actuator power OFF, disconnect the Test Meter and connect the leads to the Remote Voltmeter Indicator.
11. Turn actuator power ON. Your Remote Voltmeter Indicator should read full OPEN.
12. Further adjustment may be necessary. If the Remote Voltmeter Indicator reads less than full OPEN, carefully move the Adjustable Resistor Slider ahead being careful not to exceed the full OPEN position on the Remote Voltmeter Indicator. If the Indicator reads more than “0” when the valve is CLOSED, repeat this procedure.
13. When the Indicator properly shows valve position, lock the Adjustable Resistor Slider in place.

Figure 14: Remote Position Indicator Calibration Configuration

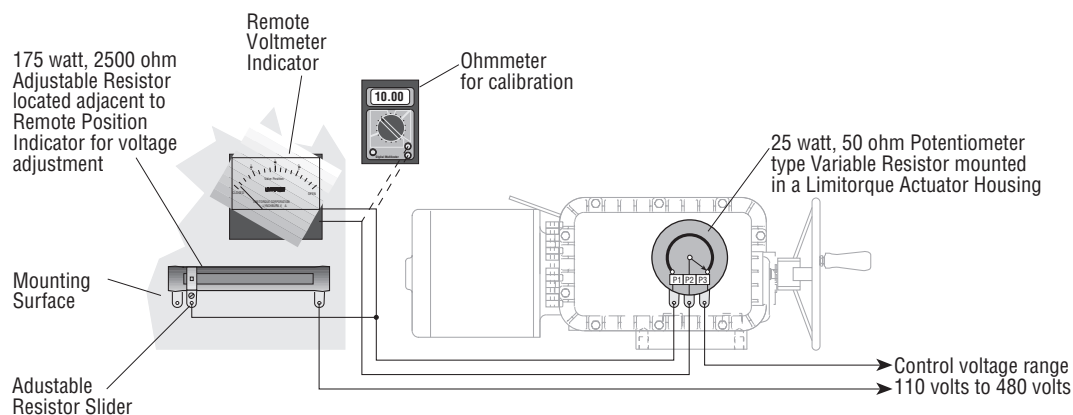

### 4.5.3 Setting the Potentiometer

If your L120-85 actuator includes a Feedback Potentiometer supplied for remote valve position indication, use an ohmmeter to calibrate the position of the Potentiometer. Typically, the Potentiometer Spur Gear is shipped from the factory dis-engaged from the Potentiometer Drive Gear. If your supplier has not re-engaged and calibrated the Potentiometer, use the following procedure to complete the Potentiometer setup.

**⚠ WARNING:** Hazardous Voltage. Turn power OFF before opening the Electrical Compartment Cover or calibrating the Feedback Potentiometer. Use extreme caution if the power is ON and the Electrical Compartment is OPEN.

1. Turn all power to the actuator OFF.
2. Using the Handwheel, position the actuator to mid-travel (valve at the 50% position).
3. Disconnect the Potentiometer Wiring Harness from the Interconnect Board or Terminal Strip.
4. Using an ohmmeter, verify that the potentiometer is in mid-travel. The resistance from each End Connection to the Center Connection should be half of the full resistance of the Potentiometer. Example: a 1000 ohm potentiometer should read approximately 500 ohms from one of the End Connections to the Center Connection. If the reading is not correct, proceed to step 5. If the reading is correct proceed to step 11.

Figure 15: Potentiometer Calibration configuration

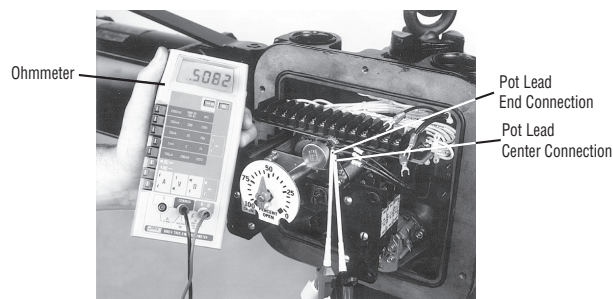

5. If the Potentiometer Assembly is engaged with the Potentiometer Drive Gear: Loosen the Hex Head Retaining Nut at the base of the Potentiometer Bracket and dis-engage the Spur Gear from the Potentiometer Drive Gear. This will allow manual rotation of the Potentiometer Spur Gear. Continue to step 7.



Figure 16: Loosening Potentiometer Assembly

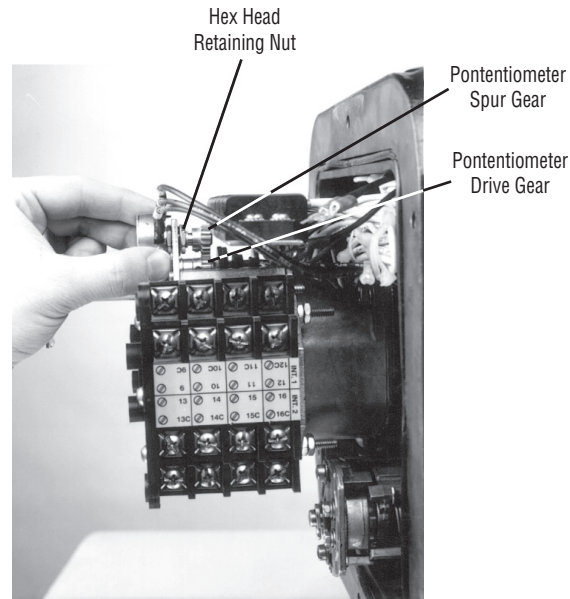

6. If the Potentiometer Spur Gear is not engaged with the Potentiometer Drive Gear continue to step 7.
7. Rotate the Potentiometer Spur Gear until the correct readings are obtained as described in step 3.
8. Carefully reposition the Potentiometer Spur Gear to re-engage with the gear train.
9. Re-tighten Hex Head Retaining Nut at the base of the Potentiometer Bracket.
10. Recheck ohmmeter reading to assure Potentiometer adjustment was not changed when Potentiometer was tightened to Potentiometer Bracket. If Potentiometer setting is not accurate, repeat steps 5–9. If ohmmeter reading is accurate, proceed to step 11.
11. Disconnect the ohmmeter and reconnect the Potentiometer wiring to the Interconnect Board or Terminal Strip.

# 5

## Operation

L120-85 actuators are always available for motor operation when the motor is energized. Do not force the Declutch Lever into the motor operation position. The Declutch Lever returns to motor operation position automatically when the motor is energized.

**NOTE:** Refer to the Illustrated Parts Breakdown in Section 10.1 as you step through the Description of Operation and the Assembly/Disassembly procedures.

### 5.1 Description of Motor Operation

In motor operation, the Motor Cam (piece 38) drives the Clutch Assembly (piece 19-1, 2, and 3) which is splined on the outer diameter and mates with the internal splines of the Clutch Pinion Assembly (piece 18-1, 2 and 3). The helical gear teeth on the Clutch Pinion (piece 18-1) mate with the Wormshaft Gear (piece 35) teeth. The Clutch Pinion and Wormshaft Gear are always engaged. The Wormshaft Gear is keyed to the Wormshaft (piece 15-1) which is keyed to the Worm (piece 15-2). Rotation of the Wormshaft/ Worm Assembly turns the Worm Gear (piece 21). Lugs on the Worm Gear engage lugs on the outer diameter of the Drive Sleeve (piece 25). Hammerblow or no lost motion is selected by the assembly arrangement of the Worm Gear and Drive Sleeve Lugs. Lugs at the base of the Drive Sleeve can drive either a Torque Drive Nut (similar to L120-10 through 40) or they can drive the lugs of the Thrust Stem Nut contained in the type Drive 2 Thrust Base Assembly.

### 5.2 Description of Manual Operation

**⚠ WARNING:** Do not manually operate actuator with devices other than installed Handwheel and Declutch lever. Using additive force devices (cheater bars, wheel wrenches, pipe wrenches or other devices of this nature) on the actuator Handwheel or Declutch Lever may cause serious personal injury and/or damage to the actuator or valve.

The L120-85 actuator has a Handwheel (piece 29) for manual operation. The actuator can be manually operated any time the Motor is not energized. To manually operate the L120- 85, push the Declutch Lever (piece 9) in the direction of the arrow until it latches in place. Pushing the Declutch Lever rotates

the Declutch Shaft which is keyed to the Declutch Link (piece 7-1). The Declutch Link engages the Clutch Ball Bearing (piece 19-2) which disengages the Clutch from the Motor Cam and engages the Handwheel Lugs (piece 3-1). The Clutch Latches (piece 32) hold the Clutch Assembly in MANUAL operation until the Motor is energized. Lobes on the Motor Cam (piece 38) cause the Clutch Latches to release when the Motor is energized. The spring-loaded Clutch (piece 19-1) reengages with the lugs on the Motor Cam. The Declutch Lever will automatically disengage when the Motor begins operating.

## 5.3 Electrical Start-up Procedure

1. Check that the actuator has been correctly lubricated. This is particularly important if the actuator has been in long-term storage.
2. Ensure that the Limit Switch and Torque Switch have been properly set.
3. If the valve stem is not visible, remove the Pipe Plug (piece 45) to observe the output direction of the Drive Sleeve (piece 25).
4. Engage MANUAL operation and hand crank actuator well away from the OPEN or CLOSED end-of-travel.
5. Turn power ON and push the OPEN button to electrically operate the actuator.
6. Check output rotation; if Motor rotation (phase) is correct, the valve will begin to open. If the valve begins to close, **Stop Immediately**.
7. Correct the Motor rotation by following the procedure “Verifying Motor Rotation Direction” in Section 4.4.
8. The actuator should operate correctly and will stop at the end of travel by the Torque and Limit Switch functions.
9. Replace Pipe Plug (piece 45).
10. If your actuator configuration has a control package, consult your specific controls package Installation and Maintenance Manual for proper set-up and calibration.

# 6

## Maintenance

### 6.1 Lubrication

#### 6.1.1 Initial Inspection

**NOTE:** Before operating your actuator, inspect it for proper lubrication, (especially if it has been stored for a long period of time). No seal can remain absolutely tight at all times; therefore, it is not unusual to find a very small amount of weeping around shaft seals — especially during long periods of idleness such as storage. Using grease minimizes this condition as much as possible. If you find a small amount of weeping at startup, remove it with a clean rag. Once the equipment is operating, the weeping should stop.

#### 6.1.2 Frequency

Base the frequency of lubrication inspections on historical data of your installed equipment. Every actuator application has its own effect on lubricants. Pattern lubricant inspections based on the needs of your facility and its applications. The following schedule of lubrication inspection should be followed until operating experience indicates otherwise.

**Gear Case:** Inspect lubrication every 18 months or 500 cycles — whichever occurs first.

#### 6.1.3 Routine Inspection

The three primary considerations in a lubrication inspection are:

1. **Quantity** — L120-85 operators are built to operate on the immersion principle. The primary concern in the amount of lubricant is whether the “worm” is totally immersed in grease.
2. **Quality** — If dirt, water or other foreign matter are found during lubrication inspection, the actuators should be flushed with a commercial degreaser/cleaner such as Exxon Varsol 18 which is not corrosive and does not affect seal materials. Repack actuator with fresh lubricant allowing room for grease thermal expansion.
3. **Consistency** — Lubricant should be slightly fluid approximating a standard NLGI-0 grade consistency or less. Thinners such as Amoco WAYTAC 31 oil may be added provided the volume of thinner does not exceed 20% of the total lubricant.

## 6.1.4 Factory Lubricants

### Gear Case

- L120-85 is factory lubricated with an EP-0 lithium base grease, suitable for temperatures from -20°F (-29°C) to + 250°F (+121°C).

**Geared Limit Switch:** Exxon Beacon 325 (no substitute).

## 6.1.5 Minimum Lubricant Qualities Required

**▲ CAUTION:** Do not mix lubricants of a different base chemical. Mixing lubricant bases may cause lubricant properties to be ineffective.

The standard lubricants used by Limitorque have been proven extremely reliable over years of service. We do not recommend a particular lubricant substitute for our standard lubricants, but below is a list of minimum lubricant qualities required by Limitorque:

- Should contain an “EP” additive.
- Must be suitable for the temperature range intended.
- Must be water and heat resistant and non-separating.
- Must not create more than 8% swell in Buna N or Viton.
- Must not contain any grit, abrasive or fillers.
- Must slump—prefer NLGI grade.
- Must not be corrosive to steel gears, ball or roller bearings.
- Dropping point must be above 316° F for temperature ranges of -20°F (-29°C) to 150°F (66°C).

# 7

## Disassembly

**⚠ WARNING:** Hazardous Voltage. Turn power OFF before disassembling your L120-85 actuator.

**⚠ WARNING:** Potential high pressure vessel. Before removing or disassembling your actuator, ensure that the valve or other actuated device is isolated and is not under pressure.

**NOTE:** Minor service may be performed with the actuator mounted on the valve or other actuated devices. Perform more complex service with the actuator removed from the valve or other actuated device.

**NOTE:** Review and familiarize yourself with the illustrated parts breakdown prior to disassembly.

**NOTE:** Drive 2 units (Thrust only) will maintain the thrust of a valve without the actuator mounted on the Thrust Base. Before removing the actuator from the Thrust Base, ensure that all actuated devices are secured to appropriate positions while actuator is removed from the Thrust Base.

### 7.1 Removal From Valve

1. Rotate the Handwheel to the fully CLOSED position.
2. Drive 1 applications (Refer to illustrated parts breakdown)
  - a. Loosen and remove customer installed Mounting Screws and Lock-washers that are holding the actuator to the Mounting Adapter.
  - b. Remove Pipe Plug (piece 45) from top of actuator Housing (piece 1).
  - c. Lift the actuator enough to loosen Key from the Drive Sleeve (piece 25).
  - d. Remove Key from the Valve Stem and the Drive Sleeve (piece 25).
  - e. Lift actuator completely off of the Mounting Adapter or Thrust Base Assembly.
3. Drive 2 applications
  - a. Loosen and remove Socket Head Cap Screws (piece 110) and Lockwashers (piece 111) at the Mounting Base of the actuator to remove the actuator from the Thrust Base Assembly.

- b. Lift actuator completely off of the Mounting Adapter or Thrust Base Assembly.
- c. Disconnect Motor and remove control wiring (see next two sections).
- d. Drive 2 Only: Rotate the Thrust Base Assembly off the threaded Valve Stem.

## 7.2 Open Electrical Compartment & Disconnect Motor

1. Turn power to the actuator OFF.
2. Open or remove the Electrical Compartment Cover (piece 200-1) by loosening pieces 200-2 and 200-3. Refer to illustrated parts breakdown.
3. Disconnect motor leads from the Terminal Strip (Refer to your wiring diagram to locate motor lead wiring numbers).

## 7.3 Remove Control Wiring

1. Slowly remove one of the Pipe Plugs (piece 50-24) to release any air pressure built up within the actuator. Refer to illustrated parts breakdown.
2. If actuator has an Integral Assembly, remove all Integral Assembly wiring that is connected to the Terminal Strip.

## 7.4 Remove Limit and Torque Switch

1. Remove the M6 Hex Head Cap Screws and Lockwashers (piece #s 305-47 and 48) from the base of the Limit Switch (piece 305).
2. Remove the M6 Socket Head Cap Screw and Lockwasher (piece #s 300-20 and 21) from the base of the Torque Switch (piece 300).
3. Remove the Limit Switch (piece 305) and Torque Switch (piece 300) from the actuator with associated wiring intact.

## 7.5 Remove Motor Assembly

1. Remove the M10 Hex Head Cap Screws and Lockwashers (piece #s 50-3 and 50-4) to remove the Motor (piece 31-1).
2. Slide the Motor (piece 31-1) away from the actuator and pull the motor leads through the conduit hole.

## 7.6 Remove Handwheel

Loosen Set Screw (piece 29-1A) from the Handwheel Hub Assembly (piece 29-1) and remove Handwheel (piece 29-2) and Handwheel Hub Assembly then remove Handwheel Shaft Key (piece 2-1) from the Handwheel Shaft (piece 2).

## 7.7 Remove Handwheel Shaft Assembly

**NOTE:** Before disassembling the Handwheel Shaft Assembly, make note of the number of Handwheel Shims (piece #s 6-1 and 6-2) that are used on each side of the Handwheel Bushing (piece 4-1). This will allow reassembly of Handwheel Shims without need to re-measure gap between actuator Housing face (piece 1) and Bushing (piece 4-1) for shimming requirements.

1. Remove the M10 Hex Head Cap Screws and Lockwashers (piece #s 50-3 and 50-4) to remove the Handwheel End Cap (piece 5).
2. Remove Handwheel Shaft Assembly comprised of (piece 2) Handwheel Shaft, (piece 3-1) Handwheel Lug, (piece 3-2) Spring, (piece 3-3) Roll Pin, (piece 4-1) Handwheel Bushing, (piece 4-2) Handwheel Spacer, (piece 4-3) Retaining Ring, (piece 6-1) Handwheel Shims, (piece 6-2) Handwheel Shims, (piece 43) O-ring and (piece 44) O-ring (not shown).

## 7.8 Remove Declutch Lever Assembly

1. Before removing the Declutch Lever Assembly (piece 9), loosen Hex Head Screws and Lockwashers (piece #s 50-5 and 50-6) and rotate the Declutch Lever Stop Plate (piece 11) in the CW  direction to free the Declutch Lever Assembly.
2. Remove Socket Head Shoulder Screws (piece 50-7) to remove the Clutch Latch Assembly (piece 32) and Latch Spring (piece 33).

## 7.9 Remove Clutch Assembly

Remove Clutch Assembly comprised of (piece 19-1) Clutch, (piece 19-2) Ball Bearing and (piece 19-3) Retaining Ring.

## 7.10 Remove Clutch Pinion Assembly

1. Use a socket wrench extension or another bar device to exert force against the face of the Clutch Pinion Assembly; this will release some of the spring tension compressed behind the Clutch Pinion Assembly by the Declutch Compression Spring (piece 30). With some of the tension released from the Clutch Pinion Assembly, use retaining ring pliers to remove Retaining Ring (piece 41) that holds the Clutch Pinion Assembly in place.
2. Remove the Clutch Pinion Assembly (piece #s 18-1, 18-2, 18-3) and the Declutch Compression Spring (piece 30).

Figure 17: Removing Clutch Pinion Assembly

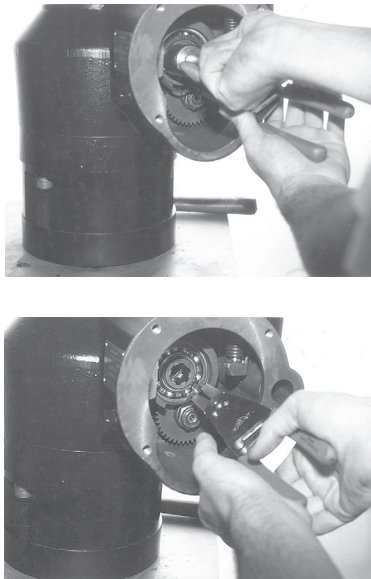

## 7.11 Remove Worm Shaft Assembly

1. Remove Flexloc Nut (piece 37) by holding Flange Nut (piece 15-10) (on opposite end of Worm Shaft Assembly) securely with a wrench.
2. Remove Washer (piece 34) and Worm Shaft Gear (piece 35).



3. Push the Worm Shaft Assembly through the opposite end of the actuator. The Worm Shaft Assembly is comprised of Worm Shaft (piece 15-1), Worm (piece 15-2), Ball Bearing (piece 15-3), Ball Bearing (piece 15-4), Disc Spring (piece 15-5-1), Spring Pack Shim (piece 15-5-2), Disc Spring Spacer (piece 15-6), Disc Spring Mandrel (piece 15-7), Bearing Adapter (piece 15-9), Flange Nut (piece 15-10), Key (piece 15-11), Retaining Ring (piece 15-12), Washer (piece 34), Worm Shaft Gear (piece 35), Key (piece 36) and Flexloc Nut (piece 37).

**NOTE:** The Spring Pack is factory preloaded and should not be disassembled from the Worm Shaft Assembly; if Spring Pack replacement is necessary, contact your Limitorque authorized dealer or the Limitorque Service Department for a complete Worm Shaft Assembly replacement.

## 7.12 Remove & Disassemble Thrust Base (if Your Unit Uses Drive 2)

1. Remove Socket Head Cap Screws (piece 110) and Lockwashers (piece 111) to remove Thrust Base Assembly from actuator Housing (piece 1).

**NOTE:** If reassembly of thrust base will use the same components, note quantity and location of shims.

2. After removing the Thrust Base Assembly from the actuator Housing and the Mounting Base, remove the Socket Head Cap Screw (piece 112) and Lockwasher (piece 113) to remove the Thrust Base Housing (piece 100) from Thrust Base Plate (piece 102). See page 55.
3. Remove the top Quad Ring (piece 107), then remove the Thrust Bearing (piece 103) and Thrust Washers (piece 104).

**NOTE:** Removing the Quad Rings (piece 107) before removing the Thrust Bearing (piece 103) and Thrust Washers (piece 104) will prevent damaging the Quad Rings.

4. Lift the Drive Sleeve (piece 101) out of the Thrust Base Plate (piece 102).
5. Pull the bottom Quad Ring (piece 107) off the Drive Sleeve, then remove the Thrust Bearing (piece 103) and Thrust Washers (piece 104).

**NOTE:** If installing a new Thrust Base or replacing components within the Thrust Base, refer to L120-85 Thrust Base assembly in the Assembly section.

## 7.13 Remove Drive Sleeve

1. Remove Socket Head Cap Screws (piece 50-1) and Lockwashers (piece 50-2) to remove the Actuator Base Plate (piece 27) from the bottom of the actuator.
2. Remove the Retaining Ring (piece 22) and Ball Bearing (piece 16) from the Drive Sleeve (piece 25).
3. Remove the rest of the Drive Sleeve Assembly through the bottom of the actuator.

# 8

## Assembly

Assembly should be conducted in the reverse order of the disassembly procedures noting the following points:

### 8.1 Handwheel Shaft Assembly and Shimming

If you have disassembled the Clutch Latch Assembly (pieces 32-1, 32-2 and 33) or have replaced the Handwheel Shaft Assembly, Clutch Pinion Assembly (piece 18), Clutch Assembly (piece 19) or Motor Cam (piece 38) you need to re-shim the Handwheel Assembly using the following procedure:

1. Remove the Retaining Ring (piece 4-3), Handwheel Spacer (piece 4-2), Handwheel Shims (piece #s 6-1 and 6-2), Handwheel Bushing (piece 4-1), O-rings (piece #s 43 and 44) and second group of Handwheel Shims (piece #s 6-1 and 6-2) from the Handwheel Shaft Assembly. Refer to the Illustrated Parts Breakdown for additional views.

Figure 18: Key components affected by Handwheel shimming (Motor Cam not shown)

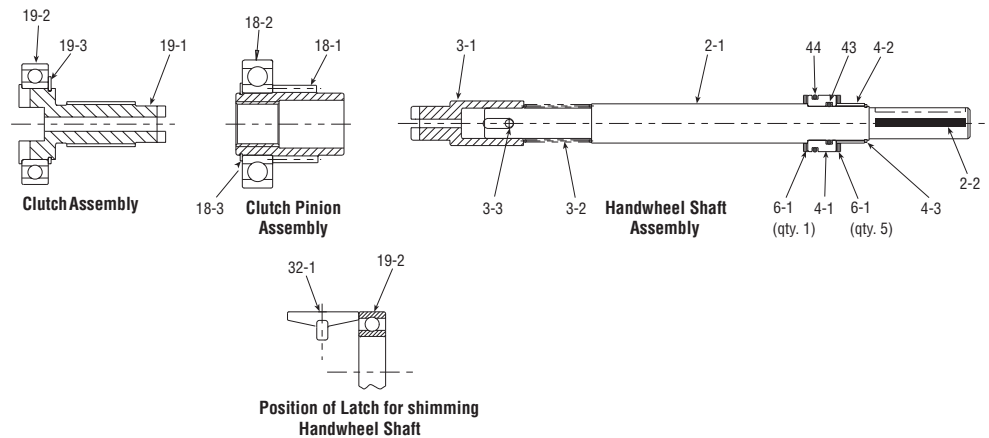

- Before shimming the Handwheel Assembly and to assure proper Handwheel Lug (piece 3-1) engagement with the Clutch (piece 19-1), push the Declutch Lever into the MANUAL mode until Latch 32-1 is engaged with Clutch Bearing (piece 19-2) as shown in figures 18 and 19. Once Clutch is engaged, leave the Declutch Lever in the declutch position during the shimming procedure.

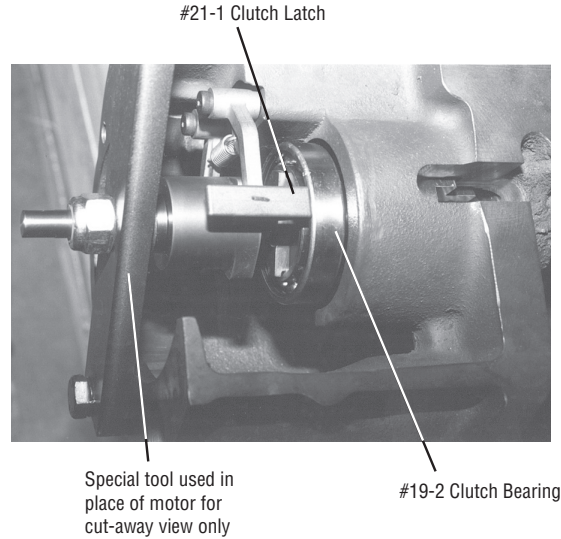
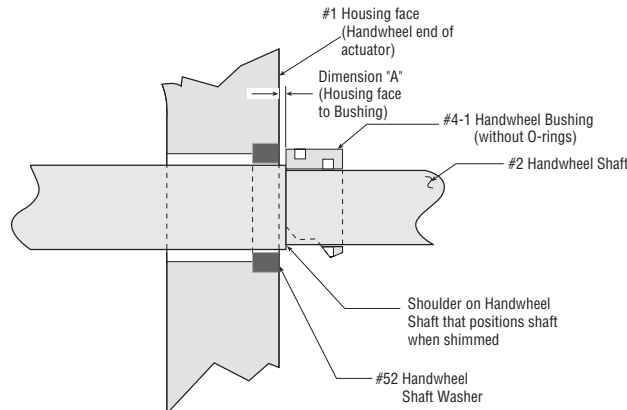

Figure 19: Cut-away view of L120-85 actuator with Clutch Latch positioned on face of Clutch Bearing

- Now insert the Handwheel Shaft Assembly (piece #s 2, 3-1, 3-2 and 3-3) (without the parts of the Handwheel Shaft Assembly removed in step 1) into the actuator (see figure 18). Assure the Handwheel Lug (piece 3-1) is fully seated into the Clutch Assembly (piece 19) by rotating the Handwheel Shaft Assembly until you feel it seat into engagement with the Clutch (piece 19-1).
- After Clutch Latch (piece 32-1) is positioned on the Clutch Bearing (piece 19-2) as described in step 2 and the Handwheel Shaft Assembly is inserted into the actuator Housing as described in step 3, insert the Handwheel Shaft Washer (piece 52) (see Figure 22) into the actuator Housing.
- Once the Handwheel Shaft is installed and fully seated, use a feeler gauge to measure the gap that is identified as Dimension “A” in Figure 20. Dimension “A” must be within the range of .000 to .180 inches (.00 mm to 4.57 mm) prior to shimming. If dimension “A” is not within the range of .000 to .180 inches (.00 mm to 4.57 mm), the assembly is incorrect and Steps 1 through 5 should be repeated.

**NOTE:** When measuring the gap, verify that Spring (piece 3-2) is at the “installed height” that is determined by the Handwheel Shaft (piece 2), Handwheel Lugs (piece 3-1) and Roll Pin (piece 3-3). If Spring (piece 3-2) is compressed an additional amount due to forcing the Handwheel Shaft into the Housing the gap measurement will be incorrect (see Figure 18).

Figure 20: Gap between Housing face and Handwheel Bushing shown as dimension “A”



- Select a shim thickness to satisfy the following chart (each shim is .030"):

Table 4: Gap "A" shim thickness selection chart

Shim Thickness for Gap "A"					
Dimension "A"				Nominal shim thickness at gap "A"	
Greater than		Less than or equal to			
0"	0 mm	.030"	0.76 mm	.03"	0.76 mm
.030"	0.76 mm	.060"	1.52 mm	.06"	1.52 mm
.060"	1.52 mm	.090"	2.29 mm	.09"	2.29 mm
.090"	2.29 mm	.120"	3.05 mm	.12"	3.05 mm
.120"	3.05 mm	.150"	3.81 mm	.15"	3.81 mm
.150"	3.81 mm	.180"	4.57 mm	.18"	4.57 mm

- Install O-rings (piece 43 and 44) on Bushing (piece 4-1). Install the proper thickness of shims, based on step 6, on the Handwheel Shaft (piece 2). The shims must rest on the major shaft diameter and be held in place by installing the Handwheel Bushing (piece 4-1) with O-rings (piece 43 and 44). The shims that fill gap "A" must lie between the Handwheel Bushing (piece 4-1) and the Handwheel Shaft Washer (piece 52). Refer to figure 18 for assembly parts drawing.
- Install Handwheel Spacer (piece 4-2) and Retaining Ring (piece 4-3) on the Handwheel Shaft (piece 2) and insert Handwheel Shaft Assembly into actuator Housing.
- Install the remaining shims (that were not used at gap "A") over the Handwheel Spacer (piece 4-2) and against Handwheel Bushing (piece 4-1). The proper thickness for shims at gap "B" is determined based on the total shim thickness for gap "A" and gap "B" combined being .18 inches (4.57 mm) total. See Figure 20 and Table 4.

Figure 21: Shimming parts and their order of assembly

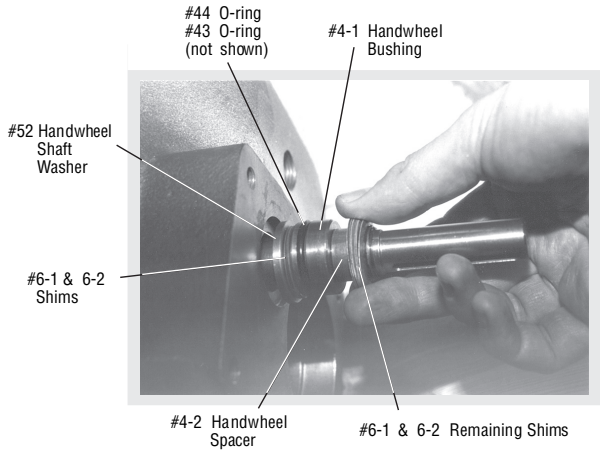

Figure 22: Shim location for gap “B” dimension

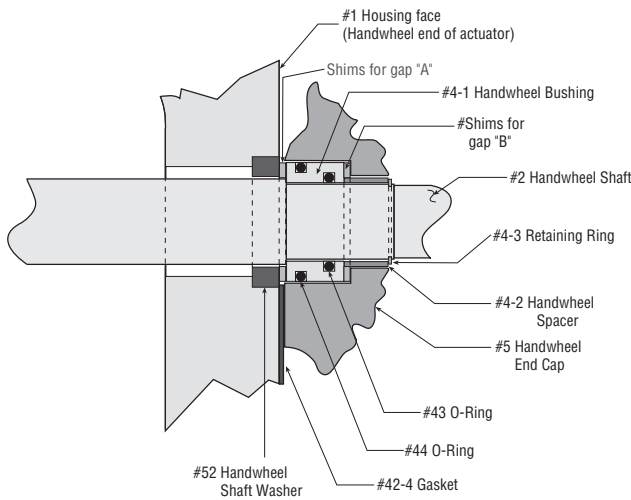

Table 5: Gap “B” shim thickness selection chart

Shim Thickness for Gap “B”			
Shim Thickness			
Used at gap “A”		Required for gap “B”	
.03"	0.76 mm	.15"	3.81 mm
.06"	1.52 mm	.12"	3.05 mm
.09"	2.29 mm	.09"	2.29 mm
.12"	3.05 mm	.06"	1.52 mm
.15"	3.81 mm	.03"	0.76 mm
.18"	4.57 mm	0"	0 mm

10. Install Gasket (piece 42-4) and Handwheel End Cap (piece 5). Secure these pieces with four Hex Head Cap Screws (piece 50-3) and Lockwashers (piece 50-4). Handwheel Shaft end play can be examined but is not required. According to dimensional tolerances, the Handwheel end play with proper shimming techniques will be .000 to .034 inches (.00 mm to 0.86 mm).
11. When reassembling the thrust base, ensure EP-0 lithium base lubricant is replaced.

## 8.2 Verifying Handwheel Operation

After your actuator is completely assembled, test the Handwheel for MANUAL operation. Put the Declutch Lever in MANUAL mode, turn the Handwheel in either direction to ensure MANUAL operation is turning the Drive Sleeve mechanism. If there is resistance to turning the Handwheel, the Declutch Lever Assembly is not properly disengaging the Motor Cam from the Clutch Pinion Assembly. If this occurs, review the Handwheel shimming procedure to ensure Handwheel shimming is accurate. If you determine the shimming procedure was correctly followed, call the Limitorque Service Department for further assistance.

## 8.3 Thrust Base Assembly and Shimming

**NOTE:** The piece numbers below are referenced on the Thrust Base Group illustrated parts breakdown.

1. Install one set of Thrust Washers (piece 104) and Thrust Bearing (piece 103) on each end of Stem Nut (piece 101). Ensure that the Thrust Bearing (piece 103) is sandwiched between the two Thrust Washers (piece 104) on either end of the Stem Nut as shown in the drawing.
2. Install the two Quad Rings (piece 107) in the seal grooves on the Stem Nut and lightly grease the seal and stem nut journal to aid in installation.
3. Place the Stem Nut into the Thrust Base Housing (piece 100) taking care not to damage the Quad Ring.
4. Install O-ring (piece 106) on the Thrust Base Plate (piece 102) and lightly grease the seal and journal to aid in installation.
5. Test fit Thrust Base Plate (piece 102) onto the Stem Nut and Thrust Base Housing taking care not to damage the two seals. Do not install the Shim Set (piece 108) at this time. It may be necessary to install several Cap Screws (piece 112) to temporarily secure the assembly.
6. Using a flat feeler guage, measure the gap between the flanges of the Thrust Base Housing and Thrust Base Plate. Then remove the Thrust Base Plate.
7. Fill the bearing cavity with grease and reinstall the Thrust Base Plate using the required quantity and thickness of shims to equal the measured gap value rounded to the nearest .005". (See Note below.)
8. Secure the assembly using the Cap Screws (piece 112) and top off the lubricant using the grease fitting.

**NOTE:** Piece 108 is a shim set consisting of two .005" thick shims and two .010" thick shims. This allows a shimming range from zero to .030" in increments of .005".

# 9 Troubleshooting

**⚠ WARNING:** Be aware of electrical and high-pressure hazards when troubleshooting or performing maintenance on your L120-85 actuator.

Symptom	Possible Cause	Corrective Action
Actuator will not operate electrically	1. No power to actuator	1a. Verify electrical supply is phased correctly and present at actuator.
		1b. Verify electrical power leads are connected in accordance with the applicable wiring diagram.
		1c. Inspect for tripped circuit breaker, overload, open disconnect switch, or blown fuse.
	2. Loose or incorrect wiring	2. Check wiring for proper connections in accordance with the applicable wiring diagram. Also check for loose connections.
	3. Limit Switches not set or incorrectly set	3. Check Limit Switch development for agreement with the applicable wiring diagram. If not set properly, follow instructions for “Setting Limit Switches”.
	4. Foreign material on switch contacts preventing good electrical contact	4. Check continuity of switches with an ohmmeter.
Motor runs, but no output from actuator	1. Actuator not coupled properly to output	1. Inspect Torque Drive Nut and Valve Shaft to verify key is in place and properly staked.
	2. Torque Drive Nut disengaged from Drive Sleeve	2. Verify Torque Drive Nut is properly installed in accordance with step 1 of the Installation Overview.
	3. Worm gear worn out	3. Remove Worm Shaft Assembly (following Disassembly Instructions). Inspect worm gear for unusual wear. If excessive wear has occurred, replace the Worm Shaft Assembly.
	4. Damaged gearing	4. Disassemble actuator following the Disassembly Instructions and inspect gearing for rough or damaged spots. Replace as required. Most frequently, damaged spots are seen in motor gear set.
Actuator operation is noisy	1. Inadequate lubrication (poor quality or not enough)	1. Inspect quality and quantity of lubrication in accordance with the Lubrication section. Add or replace lubricant as required.
	2. Worn or damaged bearings	2. Disassemble actuator and replace worn bearings, seals and lubricant.

Symptom	Possible Cause	Corrective Action
Fuse blown	1. Incorrect fuse size	1. Verify fuses are sized correctly.
	2. Pinched wire	2. Inspect control compartment to ensure Control Cover is not pinching or making contact with wiring when installed.
	3. Power surges	3. Investigate control circuit for surges.
Premature Torque Switch trip	1. Torque Switch setting too low	1. Increase Torque Switch setting as required up to, but not exceeding, the maximum setting established by the Torque Switch Limiter Plate.
	2. Valve packing too tight	2. Inspect valve packing for excessive tightness. Repair valve by replacing packing as required. Refer to your valve manufacturer for specific instructions.
	3. Actuator is not properly aligned with valve	3. Remove bolts between the actuator and the valve and check for proper actuator alignment.
	4. Valve needs lubrication	4. Check valve lubrication.
Torque Switch fails to stop actuator	1. Output rotation not in agreement with actuator wiring	1. Consult Limitorque to verify design rotation. If actual rotation is opposite of design rotation, the Torque Switch needs to have contact wiring reversed. See “Rewiring the Torque Switch for Non-Standard Drive Sleeve Rotation.”
	2. Low voltage supply to actuator	2. Check incoming voltage supply.
Excessive current draw	1. Valve running loads higher than expected	1. Inspect valve for possible causes of high running load. In particular, check for excessive tightness of valve packing and for proper lubrication of valve. Consult Limitorque for review of application.
Motor overload tripping	1. Excessive current draw	1. Inspect valve for possible causes of high running load. In particular, check for excessive tightness of valve packing and for proper lubrication of valve. Consult Limitorque for review of application.
	2. Incorrect overloads	2. Verify proper overloads selected for motor rating.
Excessive gear wear	1. Excessive loads	1. Verify actual loads are in accordance with both start and run capabilities of your actuator.
	2. Inadequate lubrication	2. Inspect quality and quantity of lubrication in accordance with the Lubrication section on pages 38–39. Add or replace lubricant as required.
	3. Improper alignment	3. Inspect worn gears for evidence of uneven wear pattern.
	4. Excessive operation (modulating actuators)	4. Review number of starts. Repeated frequent repositioning (oscillation) may indicate an unstable “loop” system. Review with Limitorque.
Excessive torque required to turn Handwheel	1. Valve running loads higher than expected	1. Inspect valve for possible causes of high running loads. In particular, check for excessive tightness of valve packing, proper lubrication of valve stem, bent or damaged valve, tight Stem/Torque Drive Nut fit, worn or damaged Stem Nut.
	2. Actuator is not properly aligned with valve	2. Take bolts off between the actuator and the valve and check for proper actuator alignment.
Oil leaking from actuator	1. Infrequent operation of actuator resulting in grease separation	1. Institute periodic operation of actuator into a maintenance program to keep grease mixed. If not possible, schedule more frequent lubrication inspections to ensure adequate lubrication of gearbox.
	2. Damaged or worn seals	2. Replace seals.





# 10

## How to Order Parts

To obtain further information or order parts for your Limitorque valve actuator, contact your local Limitorque distributor, sales office or contact:

Flowserve Limitorque  
5114 Woodall Road  
P.O. Box 11318  
Lynchburg, Virginia 24506-1318  
Attn: Service Manager  
Telephone (434) 528-4400  
Fax (434) 845-9736

Before calling with inquiries on existing actuators, be sure to have the following information from your actuator nameplate available:

- 1) Actuator size and type,
- 2) Serial number,
- 3) Limitorque order number.

## 10.1 L120-85 Illustrated Parts Breakdown

Figure 24: Electrical Compartment

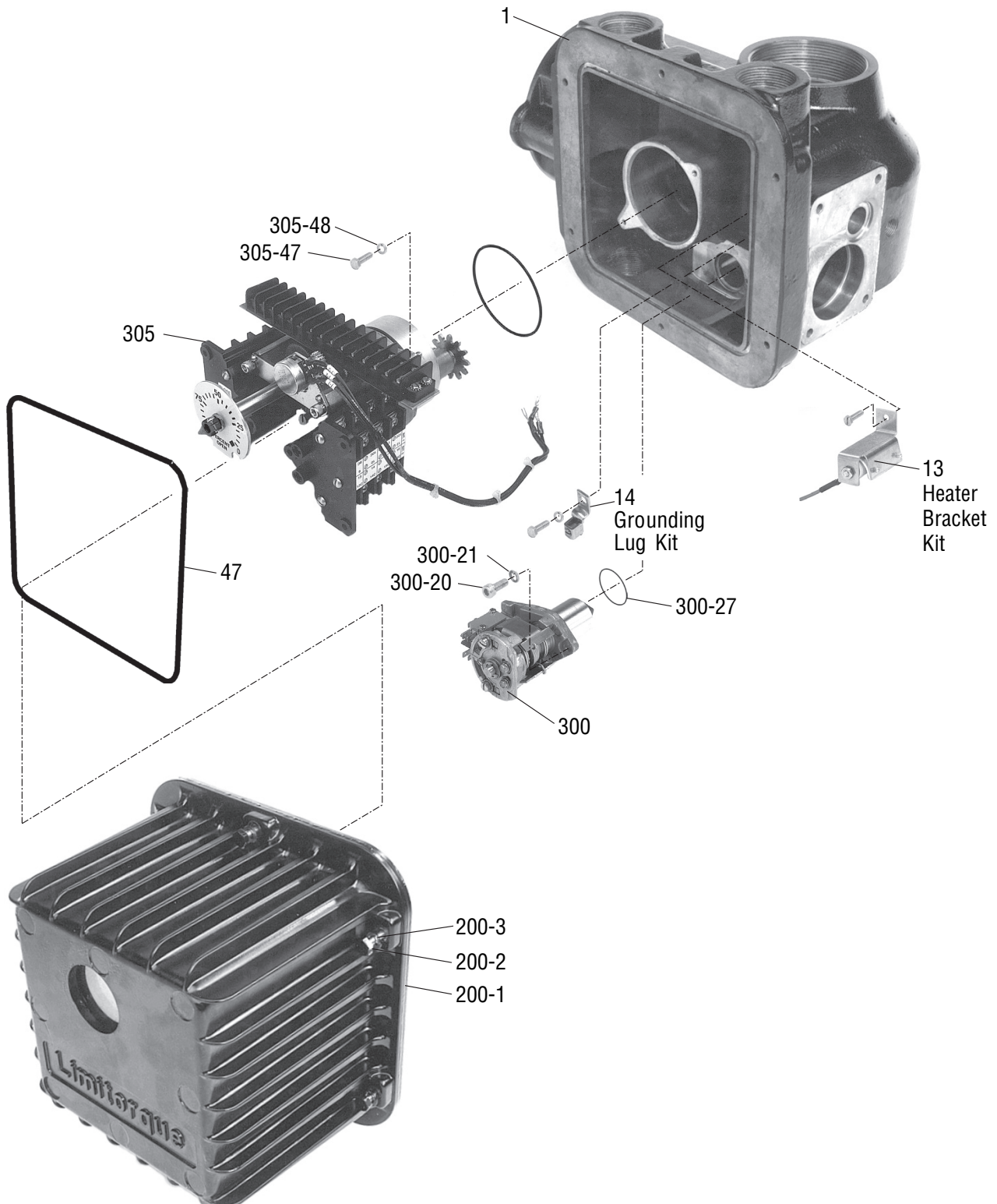

Figure 25: Motor and Motor Drive Components

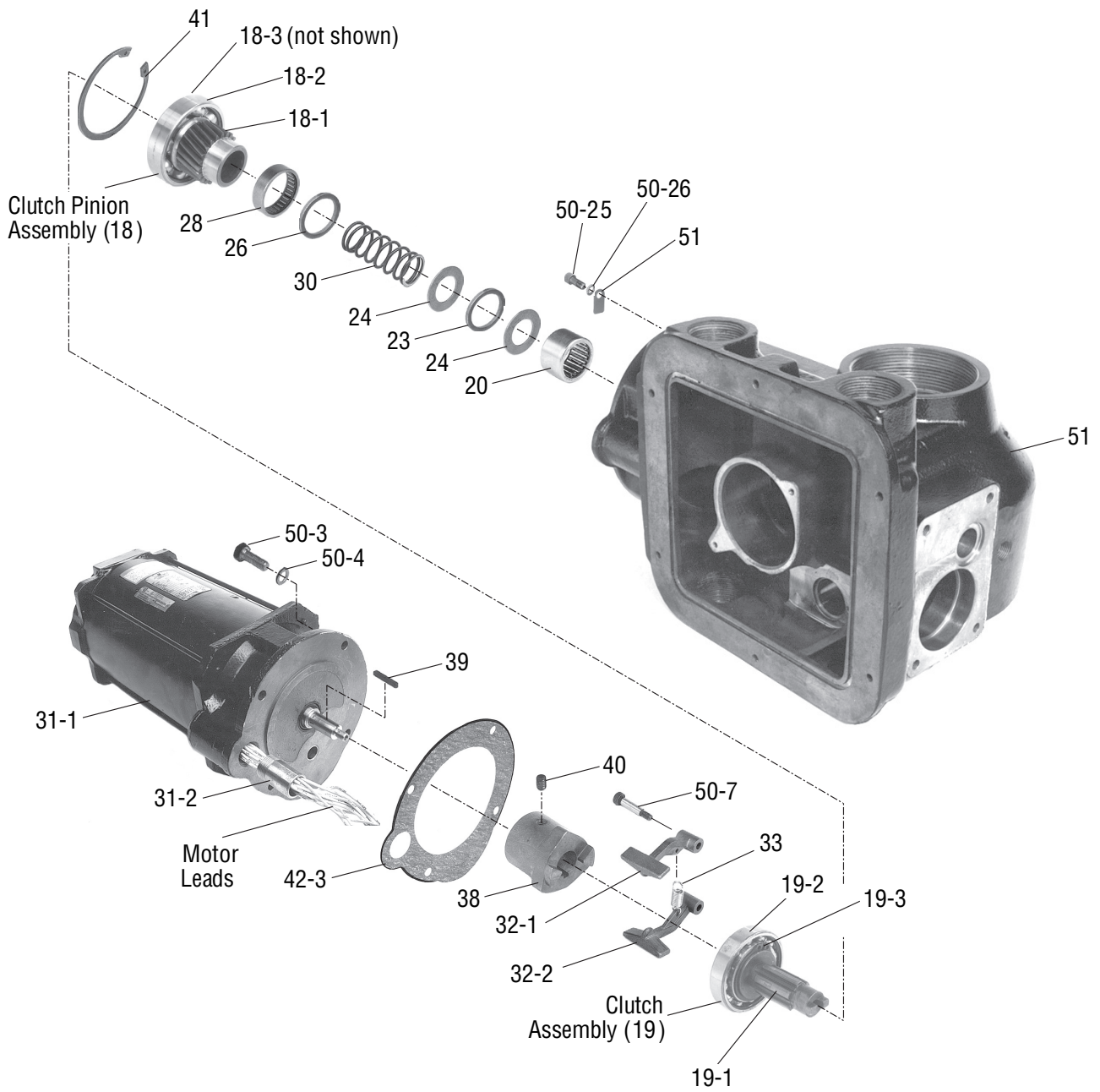

Figure 26: Handwheel Shaft and Associated Components

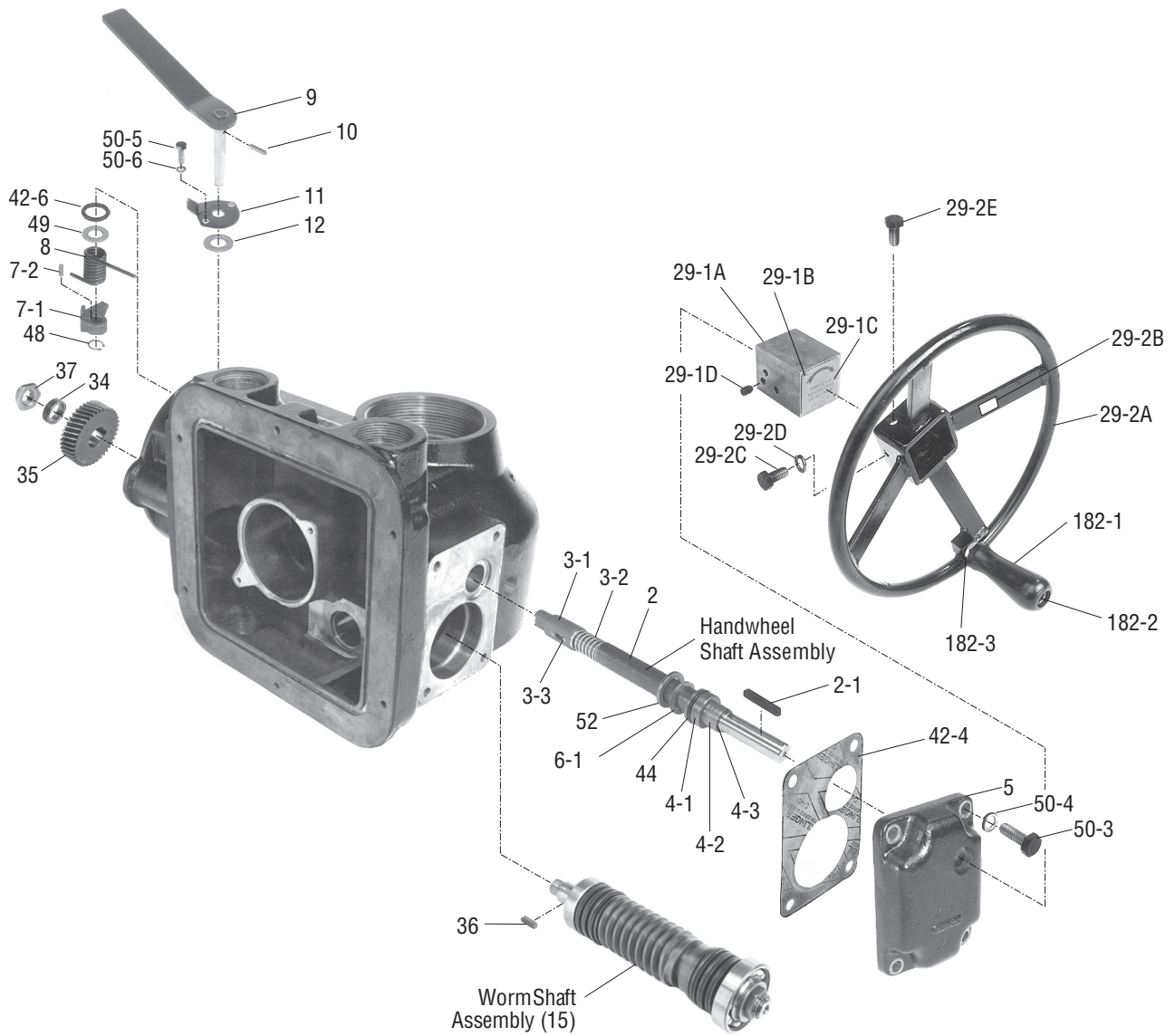

Figure 27: Drive Sleeve Group

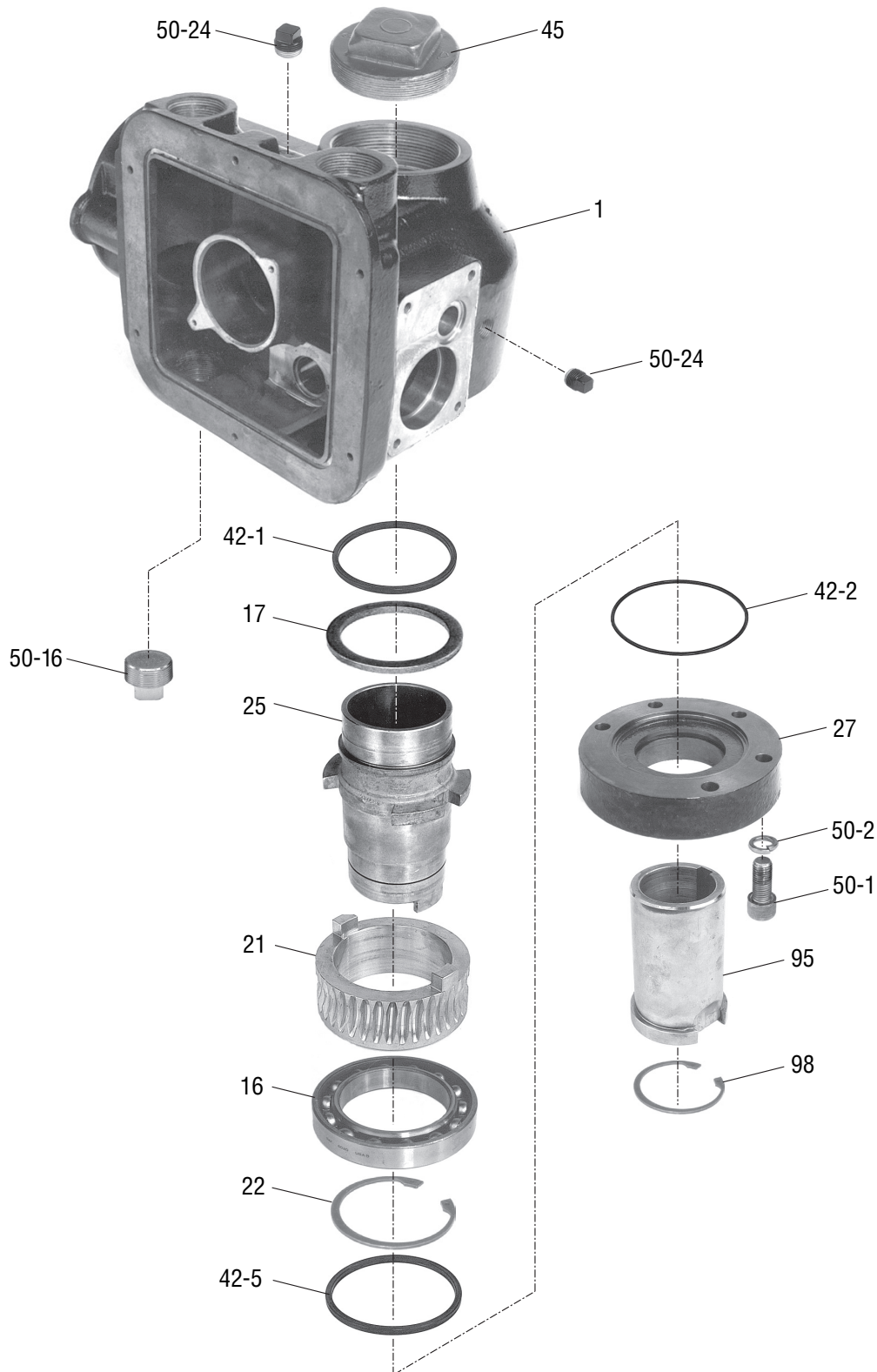
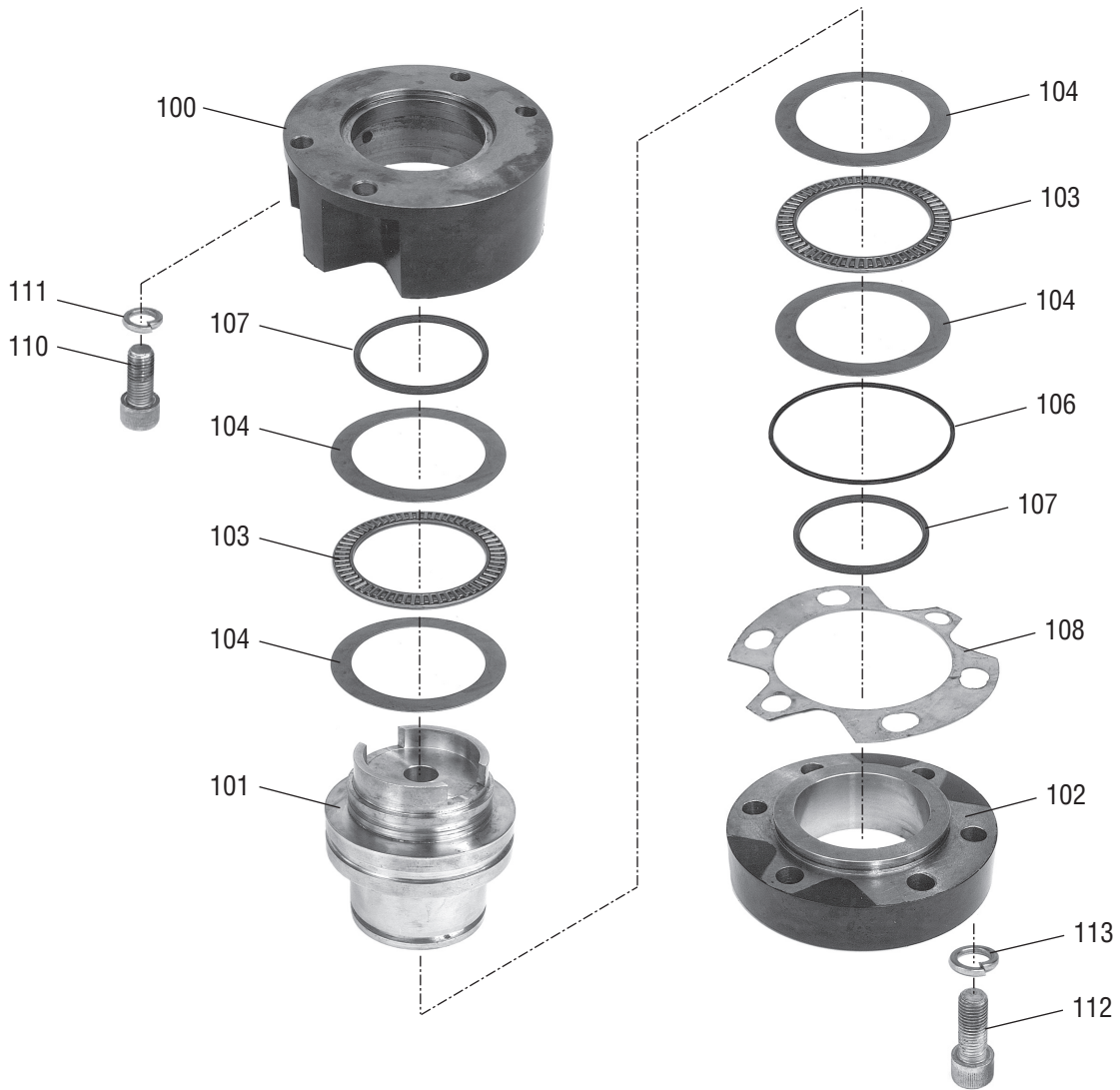



Figure 28: Thrust Base Group



## 10.2 L120-85 Parts List

Piece	Description	Quantity	Piece	Description	Quantity
1	Unit Housing	1	18-3	Clutch Pinion Retaining Ring* (not shown)	1
2	Handwheel Shaft	1	19-1	Clutch	1
2-1	Handwheel Shaft Key	1	19-2	Clutch Assy. Ball Bearing	1
3-1	Handwheel Lugs	1	19-3	Clutch Assy. Retaining Ring	1
3-2	Handwheel Shaft Spring	1	20	Handwheel Shaft Needle Bearing	1
3-3	Handwheel Shaft Roll Pin	1	21	Worm Gear	1
4-1	Handwheel Bushing	1	22	Retaining Ring	1
4-2	Handwheel Spacer	1	23	Thrust Bearing	1
4-3	Handwheel Spacer Retaining Ring	1	24	Thrust Bearing Washer	2
5	Handwheel End Cap	1	25	Drive Sleeve	1
6-1	Handwheel Shim	6	26	Bearing Backup Washer	1
7-1	Declutch Link	1	27	Unit Base Plate	1
7-2	Declutch Link Key	1	28	Needle Bearing	1
8	Declutch Return Spring	1	29-1	2" Square Nut Assembly*	1
9	Declutch Lever Assembly	1	29-2	Handwheel	1
10	Declutch Lever Roll Pin	1	30	Declutch Compression Spring*	1
11	Declutch Lever Stop Plate	1	31-1	Motor	1
12	Declutch Lever Washer	1	31-2	Conduit Nipple	1
14	Grounding Lug Kit	1	32-1	Clutch Latch	1
15-1	Worm Shaft*	1	32-2	Clutch Latch	1
15-2	Worm*	1	33	Latch Spring	1
15-3	Worm Shaft Assy. Ball Bearing*	1	34	Washer*	1
15-4	Worm Shaft Assy. Ball Bearing*	1	36	Key	1
15-5-1	Worm Shaft Assy. Disc Spring*	12	37	Flanged Lock Nut	1
15-5-2	Worm Shaft Assy. Spring Pack Shim*	12	38	Motor Cam	1
15-6	Worm Shaft Assy. Disc Spring Spacer*	2	39	Key (Motor)	1
15-7	Worm Shaft Assy. Disc Spring Mandrel*	1	40	Socket Head Set Screw	1
15-9	Worm Shaft Assy. Bearing Adapter*	1	41	Retaining Ring	1
15-10	Worm Shaft Assy. Flange Nut	1	42-1	Quad Ring	1
15-11	Worm Shaft Assy. Key	1	42-2	O-ring	1
15-12	Worm Shaft Assy. Retaining Ring	1	42-3	Motor Gasket	1
16	Drive Sleeve Ball Bearing	1	42-4	Handwheel End Cap Gasket	1
17	Drive Sleeve Top Bearing*	1	42-5	Quad Ring	1
18-1	Clutch Pinion	1	42-6	O-ring	1
18-2	Clutch Pinion Ball Bearing	1	43	O-ring (not shown)	1



Piece	Description	Quantity	Piece	Description	Quantity
44	O-ring	1	102	Thrust Base Plate	1
45	Pipe Plug	1	103	Thrust Bearing	2
47	O-ring	1	104	Thrust Washer	4
48	Retaining Ring	1	106	O-ring	1
49	Spring Retaining Washer	1	107	Quad Ring	2
50-1	Socket Head Cap Screw	5	108	Shim Set	1
50-2	Lockwasher	5	109	Grease Fitting (not shown)	1
50-3	Hex Head Cap Screw	8†	110	Socket Head Cap Screw	4
50-4	Lockwasher	8‡	111	Lockwasher	4
50-5	Hex Head Cap Screw	2	112	Socket Head Cap Screw	6
50-6	Lockwasher	2	113	Lockwasher	6
50-7	Socket Head Shoulder Screw	2	182	Spinner Kit, Hardware	1
50-16	Pipe Plug	4	200-1	Electric Compartment Cover	1
50-23	Drive Screw	4	200-2	Captive Screw	6
50-24	Pipe Plug	4	200-3	Lockwasher	6
50-25	Socket Head Cap Screw	1	300	Torque Switch	1
50-26	Lockwasher	1	300-20	Socket Head Cap Screw	1
51	Bearing Retaining Plate	1	300-21	Lockwasher	1
52	Handwheel Shaft Washer	1	305	Geared Limit Switch	1
95	Torque Drive Nut	1	305-47	Hex Head Cap Screw	2
98	Torque Drive Nut Retaining Ring	1	305-48	Lockwasher	2
100	Thrust Base Housing	1	999	Nameplate (not shown)	1
101	Thrust Base Drive Sleeve	1			

\* Worm Shaft Assembly Component

† Four used on Motor (31-1)

‡ Four used on Handwheel End Cap(s)

# 11

## EC Declaration of Conformity

**Application of Council Directives**

2004/108/EC; EMC Directive  
2006/42/EC; Machinery Directive  
2003/10/EC; Airborne Noise Directive

**Standards to which Conformity is Declared**

Machinery; EN 60204-1  
EMC; Emissions; EN 55022; 2006  
Immunity; IEC 61000-4-6; 2007, IEC 61000-4-8: 2001  
ESD; IEC 61000-4-2: 2001  
EFT Bursts; IEC 61000-4-4: 2004  
Surge Immunity; IEC 61000-4-5: 2006  
Airborne Noise; MIL-STD-740-1, Table 1, EN 60204

**Manufacturer's Name**

Flowserve-Limitorque

**Manufacturer's Address**

5114 Woodall Rd  
Lynchburg, VA 24502 USA

**Importer's Name**

Flowserve-Limitorque

**Importer's Address**

Euro House, Abex Road, Newbury, Berkshire, RG14 5EY England

**Type and Description of Equipment**

Valve Actuators

**Model Numbers**

L120-10,20,40, 85

Note: Tested with Limitorque products only and with standards applicable at the time of testing.

I, the undersigned, hereby declare that the equipment specified above conforms to the above-listed Standards and Directives.



John Thilking

Senior Engineer-Certifications, ATEX/IEC-Ex Authorized Person

Flowserve-Limitorque

5114 Woodall Rd

Lynchburg, VA 24502 USA

Date; December 4, 2012





## Flowserve Corporation

### United States

Flowserve Limatorque  
5114 Woodall Road  
P.O. Box 11318  
Lynchburg, VA 24506-1318  
Phone: 434-528-4400  
Fax: 434-845-9736

### England

Flowserve Limatorque  
Euro House  
Abex Road  
Newbury  
Berkshire, RG14 5EY  
United Kingdom  
Phone: 44-1-635-46999  
Fax: 44-1-635-36034

### Singapore

Limatorque Asia, Pte., Ltd.  
12, Tuas Avenue 20  
Singapore 638824  
Phone: 65-6868-4628  
Fax: 65-6862-4940

### China

Limatorque Beijing, Pte., Ltd.  
RM A1/A2  
22/F, East Area, Hanwei Plaza  
No. 7 Guanghua Road, Chaoyang  
District  
Beijing 100004, Peoples Republic  
of  
China  
Phone: 86-10-5921-0606  
Fax: 86-10-6561-2702

### India

Flowserve Limatorque  
Plot No. #4, 1 A, Road No. 8,  
EPIP  
Whitefield, Bangalore – 560066  
Karnataka  
India  
Phone: 91-80-40146200  
Fax: 91-80-28410286

### Italy

Flowserve Limatorque  
Fluid Power Systems  
Via Rio Vallone 17  
20883 Mezzago MB  
Italy  
Phone: 39-039-620601  
Fax: 39-039-62060 213

FCD LMENIM1202-03-AQ Printed in USA. June 2015

**To find your local Flowserve representative**  
or for more information about Flowserve Corporation, visit  
[www.flowserve.com](http://www.flowserve.com).

Flowserve Corporation has established industry leadership in the design and manufacture of its products. When properly selected, this Flowserve product is designed to perform its intended function safely during its useful life. However, the purchaser or user of Flowserve products should be aware that Flowserve products might be used in numerous applications under a wide variety of industrial service conditions. Although Flowserve can (and often does) provide general guidelines, it cannot provide specific data and warnings for all possible applications. The purchaser/user must therefore assume the ultimate responsibility for the proper sizing and selection, installation, operation, and maintenance of Flowserve products. The purchaser/user should read and understand the Installation Operation Maintenance (IOM) instructions included with the product, and train its employees and contractors in the safe use of Flowserve products in connection with the specific application.

While the information and specifications contained in this literature are believed to be accurate, they are supplied for informative purposes only and should not be considered certified or as a guarantee of satisfactory results by reliance thereon. Nothing contained herein is to be construed as a warranty or guarantee, express or implied, regarding any matter with respect to this product. Because Flowserve is continually improving and upgrading its product design, the specifications, dimensions and information contained herein are subject to change without notice. Should any question arise concerning these provisions, the purchaser/user should contact Flowserve Corporation at any one of its worldwide operations or offices.

© 2015 Flowserve Corporation, Irving, Texas, USA. Flowserve is a registered trademark of Flowserve Corporation.