



USER INSTRUCTIONS

Limitorque® L120-190 through L120-2000

FCD LMENIM1203-01-A4 – 05/15

*Installation
Operation
Maintenance*

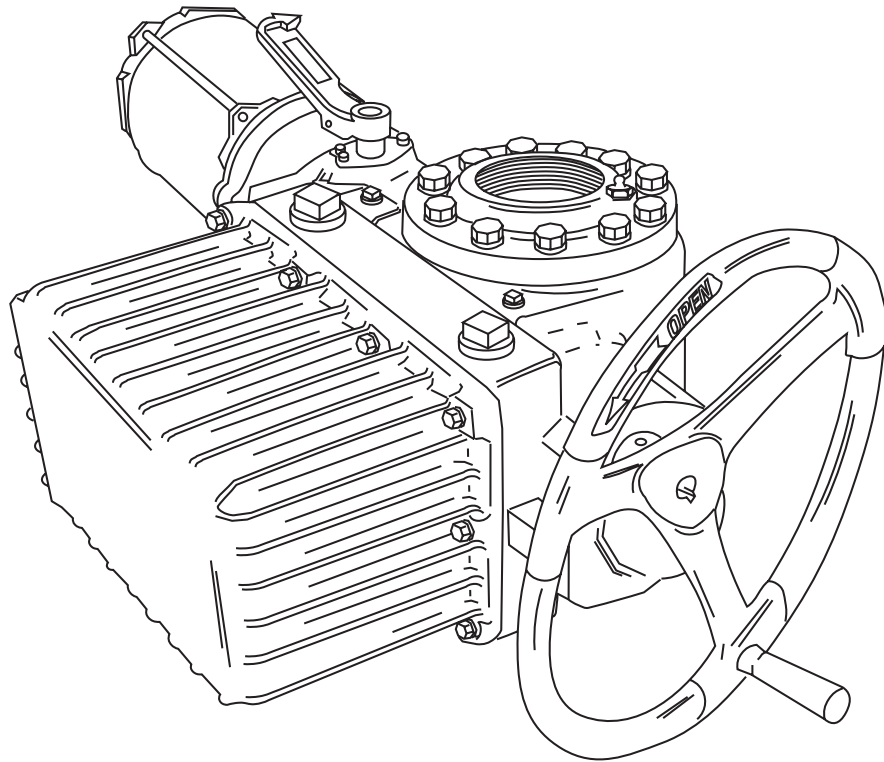



Contents

1	Introduction	5
1.1	Purpose	5
1.2	User Safety	5
2	Initial Inspection and Storage Instructions	6
2.1	Product Identification	7
2.2	Inspection and Recording	8
2.3	Short-Term Storage (less than 1 year)	8
3	Actuator Weights	10
4	Installation Instructions	11
4.1	Safety Precautions	11
4.2	Safety Practices	12
4.3	Actuator Preparation	12
4.3.1	Mounting Base	13
4.3.2	Stem Acceptance	13
4.4	Double Torque Switch	13
4.4.1	Setting Torque Switch	14
4.4.2	Balancing Torque Switch	15
4.4.3	Torque Switch Terminal Connections	15
4.5	Geared Limit Switch – Rotor Type	16
4.5.1	Setting Limit Switch	16
4.5.2	Combination of Contacts	19
4.6	Position Indication	19
4.6.1	Local Position Indication	19
4.6.2	Remote Position Indication	20
4.6.3	Calibrating Position Transmitter PT20SD	20
5	Operation	21
5.1	Electrical Start-Up	21
5.1.1	Typical Wiring Diagram	22
5.2	Manual Operation	22
5.3	Motor Operation	23
5.4	Torque and Travel Limiting	23
6	Maintenance	24
6.1	Lubrication	24
6.1.1	Lubrication Inspection	24
6.1.2	Factory Lubricant	25
7	Disassembly and Reassembly	26
7.1	L120-190, -420, and -800	26
7.1.1	To Replace Stem Nut Only	26
7.1.2	L120-190, 420, 800 Disassembly	27
7.1.3	Reassembling Actuator Sizes L120-190, -420 and -800	28
7.1.4	Gaskets	29
7.2	L120-2000	38
7.2.1	Drive 2 Disassembly (Thrust Housing Only)	38
7.2.2	Drive 1 Disassembly (Torque Housing)	38
7.2.3	Drive 1 (Torque Housing) Reassembly	40
7.2.4	Drive 2 (Thrust Housing Only) Reassembly	42
8	Standard Wiring Diagrams	49
9	Troubleshooting	52

10	How to Order Parts	53
11	EC Declaration of Conformity	54

Figures

Figure 2.1	– L120-190 through 2000	8
Figure 4.1	– Double Torque Switch	13
Figure 4.2	– Setting Torque Switch	14
Figure 4.3	– Ring Tongue Terminal	15
Figure 4.4	– Geared Limit Switch	17
Figure 4.5	– Setting Geared Limit Switch	18
Figure 4.6	– Position Indicators	19
Figure 4.7	– Typical Connection for a 1000 ohm Potentiometer	20
Figure 7.1	– L120-190 and -420 Drive Sleeve Side View (Refer to Table 8.1 for parts list)	30
Figure 7.2	– L120-190 and -420 Worm Shaft Side View (Refer to Table 8.1 for parts list)	31
Figure 7.3	– L120-190 and -420 Top View (Refer to Table 8.1 for parts list)	32
Figure 7.4	– L120-800 Drive Sleeve Side View (Refer to Table 8.1 for parts list)	33
Figure 7.5	– L120-800 Worm Shaft Side View (Refer to Table 8.1 for parts list)	34
Figure 7.6	– L120-800 Top View (Refer to Table 8.1 for parts list)	35
Figure 7.7	– L120-2000 Drive Sleeve Side View (Torque Base) (Refer to Table 8.2 for parts list)	43
Figure 7.8	– L120-2000 Top View (Refer to Table 8.2 for parts list)	44
Figure 7.9	– L120-2000 Side View (Refer to Table 8.2 for parts list)	45
Figure 7.10	– L120-2000 Exploded View	46
Figure 8.1	– Wiring Diagram – No Controls	49
Figure 8.2	– Wiring Diagram – Integral Controls	50
Figure 8.3	– Wiring Diagram – NCU	51

Tables

Table 3.1	– Actuator Weights	10
Table 4.1	– Mounting Base Dimensions	13
Table 4.2	– Maximum Stem Acceptance	13
Table 4.3	– Terminal Dimensions By Cable Size	16
Table 4.4	– Maximum Drive Sleeve Turns	17
Table 6.1	– Lubricant Weights	25
Table 7.1	– L120-190, -420 and -800 typical parts list	36
Table 7.2	– L120-2000 typical parts list	47

1 Introduction

1.1 Purpose

This Installation, Operation, and Maintenance Manual explains how to install and maintain L120-190 through -2000 actuators. Information on installation, disassembly, reassembly, lubrication, and parts is provided.

1.2 User Safety

Safety notices in this manual detail precautions the user must take to reduce the risk of personal injury and damage to the equipment. The user must read and be familiar with these instructions before attempting installation, operation, or maintenance. Work to be performed on the actuator should be carried out by a qualified tradesman familiar with the operation and maintenance of electric actuators. Failure to observe these precautions could result in serious bodily injury or death, damage to the equipment, warranty void, or operational difficulty.

Safety notices are presented in this manual in three forms:

⚠ **WARNING:** Refers to personal safety. Alerts the user to potential danger. Failure to follow warning notices could result in personal injury or death.

⚠ **CAUTION:** Directs the user's attention to general precautions that, if not followed, could result in personal injury and/or equipment damage.

NOTE: Highlights information critical to the user's understanding of the actuator's installation and operation.

2

Initial Inspection and Storage Instructions

L120 Series actuators operate without modification in any rising or non-rising stem application for linear-action valves.

The actuators meet rigid safety requirements and are available in weatherproof, explosionproof, and submersible configurations.

The actuators are compatible with a wide range of control options from stand-alone actuators with local control stations to open standards-based DDC-100 networks with up to 250 actuators.

The actuators are designed with integral control packages including plug-in interconnect boards that increase control functionality for stand-alone or networked actuators.

Torque overload protection is provided in both directions of travel.

⚠ **WARNING:** Read this Installation and Maintenance Manual carefully and completely before attempting to store the actuator. Be aware of the electrical hazards.

2.1 Product Identification

The actuator nameplate is located on the back of the actuator opposite the limit switch controls compartment. The nameplate contains the following information:

- Limitorque name
- Point of manufacture
- Actuator size
- Order number
- Serial number
- Customer tagging

The motor nameplate is located on the motor. The nameplate contains the following information:

- ID number
- Run torque
- RPM
- Full load amps
- Insulation class
- Space heater size
- Service Factor
- Cycles
- Ambient temperature
- Start torque
- Enclosure type
- Volts
- Locked rotor amps
- Duty
- Horsepower
- Phase
- Motor code
- Connection diagram

Figure 2.1 – L120-190 through 2000

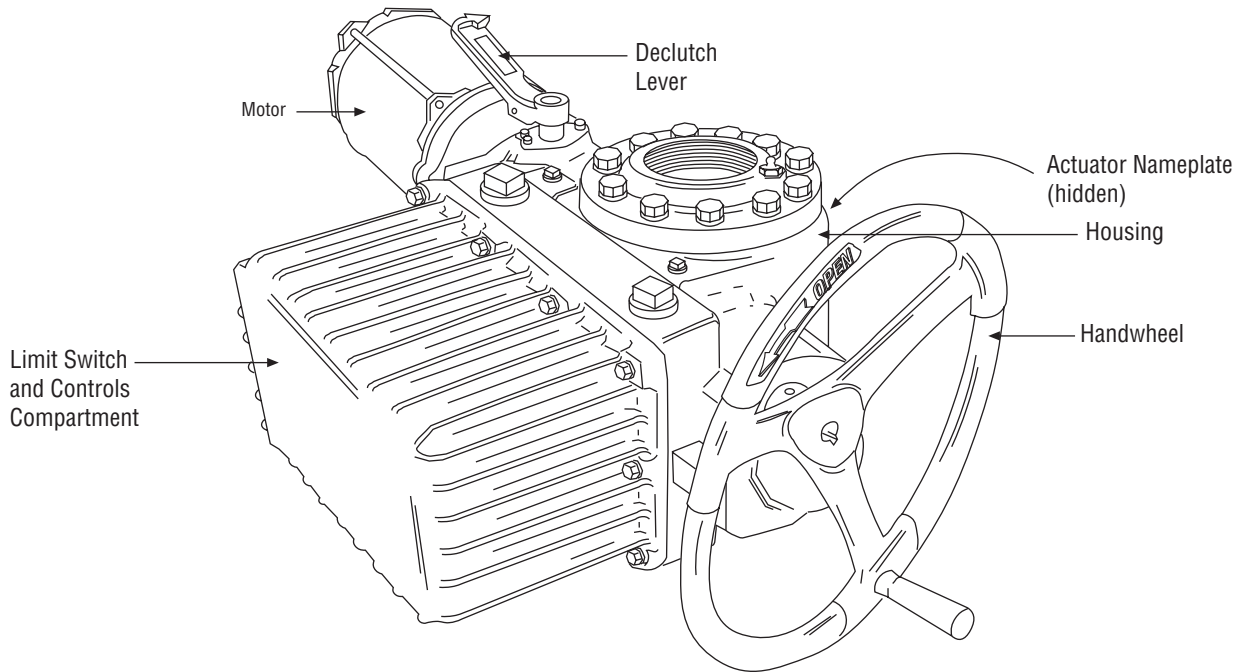

2.2 Inspection and Recording

Upon receipt of the actuator, inspect the condition of the equipment and record nameplate information.

1. Carefully remove actuator from shipping carton or skid. Thoroughly examine the equipment for any physical damage that may have occurred during shipment. If damaged, immediately report the damage to the transport company.
2. Record the actuator nameplate information for future reference, i.e., ordering parts, obtaining further information.

NOTE: The following are our recommended storage procedures to retain maximum product integrity during short-term storage. Failure to comply with recommended procedures will void the warranty. For longer-term storage, contact Limitorque for procedures and recommendations.

2.3 Short-Term Storage (less than 1 year)

Actuators are not weatherproof until properly installed on the valve or prepared for storage.

Store actuators in a clean, dry, protected warehouse away from excessive vibration and rapid temperature changes. If the actuators must be stored outside, they must be stored off the ground, high enough to prevent them from being immersed in water or buried by snow.

1. Position the actuator in storage with motor and switch compartment horizontal.
2. Connect the space heaters (if supplied) or place desiccant in the switch compartment.
3. Connect space heaters if actuator is to be stored in a damp place.
4. Replace all plastic caps or plugs with pipe plugs and ensure that all covers are tight.
5. If the actuator is mounted on a valve and the stem protrudes from the actuator, a suitable stem cover must be provided.

3

Actuator Weights

The approximate L120 actuator weights are provided below:

Table 3.1 – Actuator Weights

Actuator Size	Control Types	Drive 1 Weight Side HW		Drive 2 Weight Side HW	
		lb.	kg	lb.	kg
L120-190	NCU ³	520	192	520	192
	BIC ³	586	217	586	217
	UEC/Clamshell ³	586	217	586	217
L120-420	NCU ³	1065	394	1065	394
	BIC ³	1130	418	1130	418
	UEC/Clamshell ³	1220	451	1220	451
L120-800	NCU ³	1270 ¹	471 ¹	1700 ²	629 ²
L120-2000	NCU ³	2500 ¹	925 ¹	3300 ²	1221 ²

Note 1: Torque Only

Note 2: Torque and Thrust

Note 3: NCU = No Controls Actuator

BIC = Basic Integral Controls

UEC = Universal Electronic Controller

4

Installation Instructions

4.1 Safety Precautions

- ⚠ **WARNING:** Read this Installation, Operation, and Maintenance Manual carefully and completely before attempting to install, operate, or troubleshoot the Limitorque actuator.

- ⚠ **WARNING:** Be aware of electrical hazards. Turn off incoming power before working on the actuator and before opening the switch compartment.

- ⚠ **WARNING:** Potential HIGH PRESSURE vessel — be aware of high-pressure hazards associated with the attached valve or other actuated device when installing or performing maintenance on the actuator. Do not remove the actuator mounting bolts from the valve or actuated device unless the valve or device stem is secured to prevent movement of the stem or there is no pressure in the line.

- ⚠ **WARNING:** For maintenance and/or disassembly of the actuator while installed on the valve, ensure that the actuator is not under thrust or torque load. If the valve must be left in service, the valve stem must be locked in such a way as to prevent any movement of the valve stem.

- ⚠ **WARNING:** Do not attempt to remove the spring cartridge cap, housing cover, or stem nut locknut from the actuator while the valve or actuated device is under load.

- ⚠ **WARNING:** Do not manually operate the actuator with devices other than the installed hand-wheel and declutch lever. Using force beyond the ratings of the actuator and/or using additive force devices such as cheater bars, wheel wrenches, pipe wrenches, or other devices on the actuator handwheel or declutch lever may cause serious personal injury and/or damage to the actuator and valve.

- ⚠ **WARNING:** Do not exceed any design limitations or make modifications to this equipment without first consulting Limitorque.

- ⚠ **WARNING:** Actuators equipped with electrical devices (motors, controls) requiring field wiring must be wired and checked for proper operation by a qualified tradesman.
- ⚠ **WARNING:** Use of the product must be suspended any time it fails to operate properly.
- ⚠ **CAUTION:** Do not use oversized motor overload heaters. Instead, look for the cause of the overload.
- ⚠ **CAUTION:** Do not operate the valve under motor operation without first setting or checking the limit switch setting and motor direction.
- ⚠ **CAUTION:** Do not force the declutch lever into the motor operation position. The lever returns to this position automatically when the motor is energized.
- ⚠ **CAUTION:** Do not depress the declutch lever during motor operation to stop valve travel.
- ⚠ **CAUTION:** Do not use replacement parts that are not genuine Flowserve Limitorque parts, as serious personal injury and/or damage to the actuator and valve may result.
- ⚠ **CAUTION:** Do not lift actuator/gearbox or actuator/valve combinations with only the eye bolts in the L120 actuator. These eye bolts are designed for lifting the L120 actuator only.
- ⚠ **CAUTION:** Do not lift the actuator by handwheel.

4.2 Safety Practices

The following check points should be performed to maintain safe operation of the L120 actuator:

- Eye bolts are designed for lifting only the actuator and not associated gearboxes or valves.
- Mount motor on a horizontal plane, if possible. Preferably, keep the motor or limit switch compartment from hanging down. This prevents head of grease from being against motor or switch seals.
- Keep the switch compartment clean and dry.
- Keep the valve stem clean and lubricated.
- Set up periodic operating schedules for infrequently used valves.
- Verify that all actuator wiring is in accordance with the applicable wiring diagram.
- Carefully check for correct motor rotation direction. If the motor is driving the valve in the wrong direction, interchange any two leads on the three-phase motor or switch the armature leads on DC motors.
- Use a protective stem cover. Check valve stem travel and clearance before mounting covers on rising stem valves.
- Verify that a locking nut tightly secures the stem nut and that the top thread of the lock nut is crimped and staked in two places.
- For the DC motor, keep the armature clean and periodically check brushes for proper contact and wear.

4.3 Actuator Preparation

NOTE: Replace all molded plastic conduit and top protectors (installed for shipping purposes only) with pipe plugs when installation wiring is complete.

4.3.1 Mounting Base

The mounting hole sizes and quantities are as detailed in Table 4.1, below:

Table 4.1 – Mounting Base Dimensions

Actuator Size	Mounting Holes Quantity	Tap Size	ISO	Bolt Circle	ISO
		MSS		MSS	
L120-190	8	3/4-10 x 1.13	M20 x 2.5 x 32	11.75	298 mm
L120-420	8	7/8-9 x 1.75	N/A	14.0	N/A
L120-800 (Torque Only)	8	3/4-10 x 1.63	N/A	17.0	N/A
L120-800 (Thrust Only)	8	1.25-7 x 2.0	N/A	16	N/A
L120-2000 (Torque Only)	16	1-8 x 2.0	N/A	23.5	N/A
L120-2000 (Thrust Only)	12	1-1/2-6 x 3.0	N/A	18.0	N/A

4.3.2 Stem Acceptance

The maximum stem acceptance is provided in Table 4.2, below:

Table 4.2 – Maximum Stem Acceptance

Actuator size	Drive 2 Tapped		Drive 1 Bore		Drive 1 Key	
	inch	mm	inch	mm	inch	mm
L120-190	3.5	89	2.875	73	3/4 x 1/4	20 x 12
L120-420	5	127	4.25	108	1 x 3/4	28 x 16
L120-800	5	127	7	178	1 x 3/4	32 x 18
L120-2000	6.25	159	8.00	203	1 1/4 x 7/8	40 x 22

NOTE: For complete mounting dimensions, see sales brochure LMENBR1200.

4.4 Double Torque Switch

The torque switch is designed to protect the actuator in open and close directions.

Figure 4.1 – Double Torque Switch

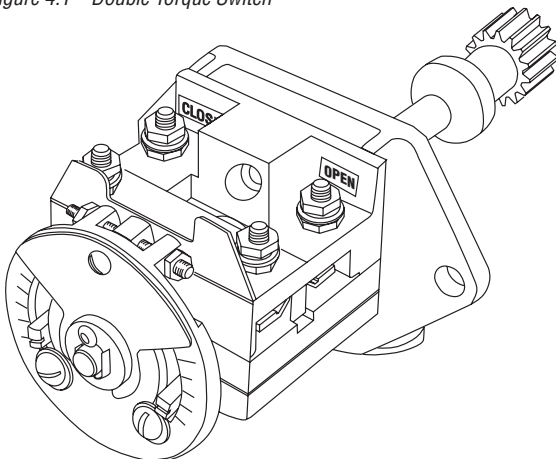

NOTE: See Caution and Note on following page.

▲ **CAUTION:** Disconnect all incoming power before opening limit switch compartment or working on the torque switch.

- Do not use abrasive cloth to clean the contacts on the torque switch.
- Do not torque-seat 90° operation valves or run them against the stops. This may cause damage to the valve.

NOTE: If the actuator has “torqued out,” release torque buildup by operating the actuator manually in opposite direction ½ to 1 turn of the output drive sleeve.

NOTE: Torque switch contacts are rated 600 volts, in accordance with NEMA ICS-2.

4.4.1 Setting Torque Switch

The torque switch was set at the factory according to customer-supplied information regarding necessary torque or thrust output provided at the time of the order. However, if the torque switch is newly installed or the setting needs to be adjusted, follow the procedure below:

▲ **CAUTION:** A maximum stop setting plate is provided on most actuators (Figure 4.2). Do not remove this plate. Do not exceed the setting indicated by this plate without contacting Limitorque.

- Installing or adjusting the torque switch with the operator in a “loaded” condition will result in a loss of torque protection.

Item letters correspond to Figure 4.2.

1. Place the L120 actuator in manual mode.
2. Release the load on the wormshaft spring pack. Put operator in manual mode and operate in opposite direction until switch is in neutral position.
3. For open and close directions, loosen Screw (A) and move Pointer (B) to desired position. A higher number indicates a high torque and/or thrust output.
4. Tighten Screw (A).
5. Operate the valve electrically to seat the valve and to ensure tight shutoff.

Figure 4.2 – Setting Torque Switch

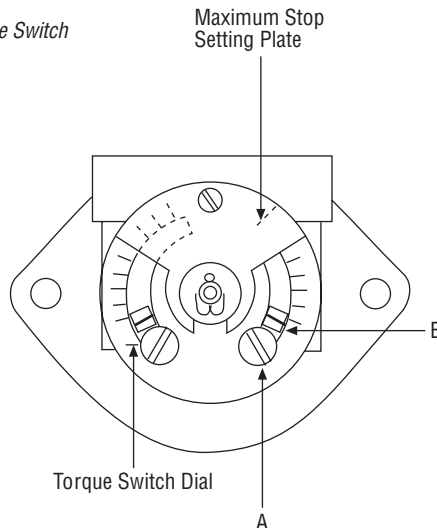

4.4.2 Balancing Torque Switch

Item letters correspond to Figure 4.2.

1. Place the actuator in manual mode.
2. Remove the load from the wormshaft spring pack.

NOTE: If the actuator torque switch has opened and de-energized the actuator, release the torque buildup by operating the actuator manually in opposite direction ½ to 1 turn.
3. Note the open and close torque switch settings prior to re-installing the torque switch.
4. Loosen Screws (A) and position both Pointers (B) at the #1 setting; tighten Screws (A).
5. Mount the torque switch and tighten the mounting screws. Verify that both contact pointers are touching the arms. The interface between the pointers and the arm is found beneath the torque switch dial. If the pointers and the arms are not in contact, the clearance on the open and close torque switches should be equal. If not equal, the torque switch needs to be balanced. (See Step 7.)
6. If the pointers and arms are in contact on both sides of the switch, manually rotate the torque switch dial clockwise and counter-clockwise to determine if there is equal backlash in both directions of rotation. If there is not equal backlash in both directions, the torque switch needs to be balanced. (See Step 7.)
7. Loosen both hex nuts.
8. Back out one setscrew and tighten the other setscrew until there is equal backlash in both directions of rotation of the dial, or equal clearance between the pointers and arms.
9. Tighten the hex nuts and return the torque switch to its original settings.

▲ CAUTION: The balancing screws should not be touched except during the balancing procedure.

The switch is now balanced and ready for the pointers to be returned to their original settings.

4.4.3 Torque Switch Terminal Connections

Wiring connections to the L120 geared limit switch, torque switch, and marathon terminal strips are to be made using ring-tongue terminals as shown below:

Figure 4.3 – Ring Tongue Terminal

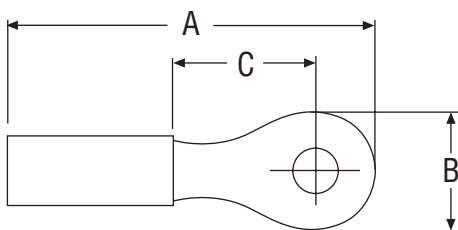

See Table 4.3, next page

Table 4.3 – Terminal Dimensions By Cable Size

AWG	Screw Hole	Insulation	Thomas & Betts P/N	A	B	C
22-16	#10	Vinyl	18RA-10	.97	.31	.27
18-14	#10	Vinyl	14RB-10	.97	.31	.27
12-10	#10	Vinyl	14RC-10	1.06	.31	.27

Terminals are to be crimped using Thomas & Betts crimping tool WT111M.

4.5 Geared Limit Switch – Rotor Type

▲ CAUTION: The geared limit switch is not preset at the factory and must be adjusted after the actuator has been mounted on associated equipment.

NOTE: Limit switch contacts are rated 600 volts, in accordance with NEMA ICS-2

- Disconnect all incoming power to the actuator prior to opening the limit switch compartment and adjusting the switch.
- Consult the relevant wiring diagram for limit switch contact development. All L120 actuators are supplied with 16-contact limit switches - four switches on each of the four rotors. Two rotors are used for end-of-travel indication. The remaining two rotors may be adjusted for any intermediate point-of-travel.
- Do not use abrasive cloth to clean the contacts on the limit switch.
- Do not attempt to repair gearing in the limit switch. Replace entire gear frame assembly if necessary.

4.5.1 Setting Limit Switch

The maximum number of drive sleeve turns available is a function of actuator size, worm gear ratio, and type of switch. See Table 4.4. The Intermediate Shaft shown in Figure 4.5 may take a considerable number of turns before rotor trip occurs.

⚠ WARNING: Potential Explosion Hazard. Do not use an electric drill for setting the limit switch in an explosive environment.

▲ CAUTION: When setting the limit switch rotor segments (cams) using a variable speed electric drill, do not run drill at speeds higher than 200 RPM. Operating the drill at high speeds can damage the gearing within the limit switch.

Table 4.4 – Maximum Drive Sleeve Turns

Actuator Size	Limit Switch Gearing			PIC Gearing	
	W.G. Ratio	4-Gear	5-Gear	PIC or R/I (270)	RVDT(90)
L120-190	13.3:1	3110	31100	13706	4569
	33:1	1250	12500	5521	1837
	60:1	690	6900	3037	1012
	85:1	N/A	N/A	N/A	N/A
L120-420	10.33:1	N/A	N/A	N/A	N/A
	16:1	3300	33000	11405	3797
	41:1	1280	12800	4445	1481
	57:1	910	9100	3195	1065
	80:1	N/A	N/A	N/A	N/A
L120-800	12.67:1	N/A	N/A	N/A	N/A
	19:1	2850	28500	9586	3195
	49:1	1050	10500	3720	1240
	58:1	N/A	N/A	N/A	N/A
	86:1	N/A	N/A	N/A	N/A
L120-2000	43:1	1210	12100	4234	1413
	71:1	740	7400	2566	855

Figure 4.4 – Geared Limit Switch

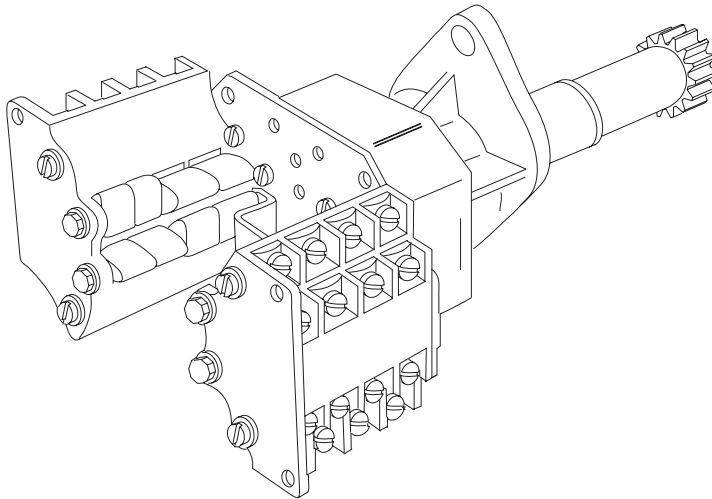

Set the limit switch as shown on the following page. All item letters and piece numbers refer to Figure 4.5.

Figure 4.5 – Setting Geared Limit Switch

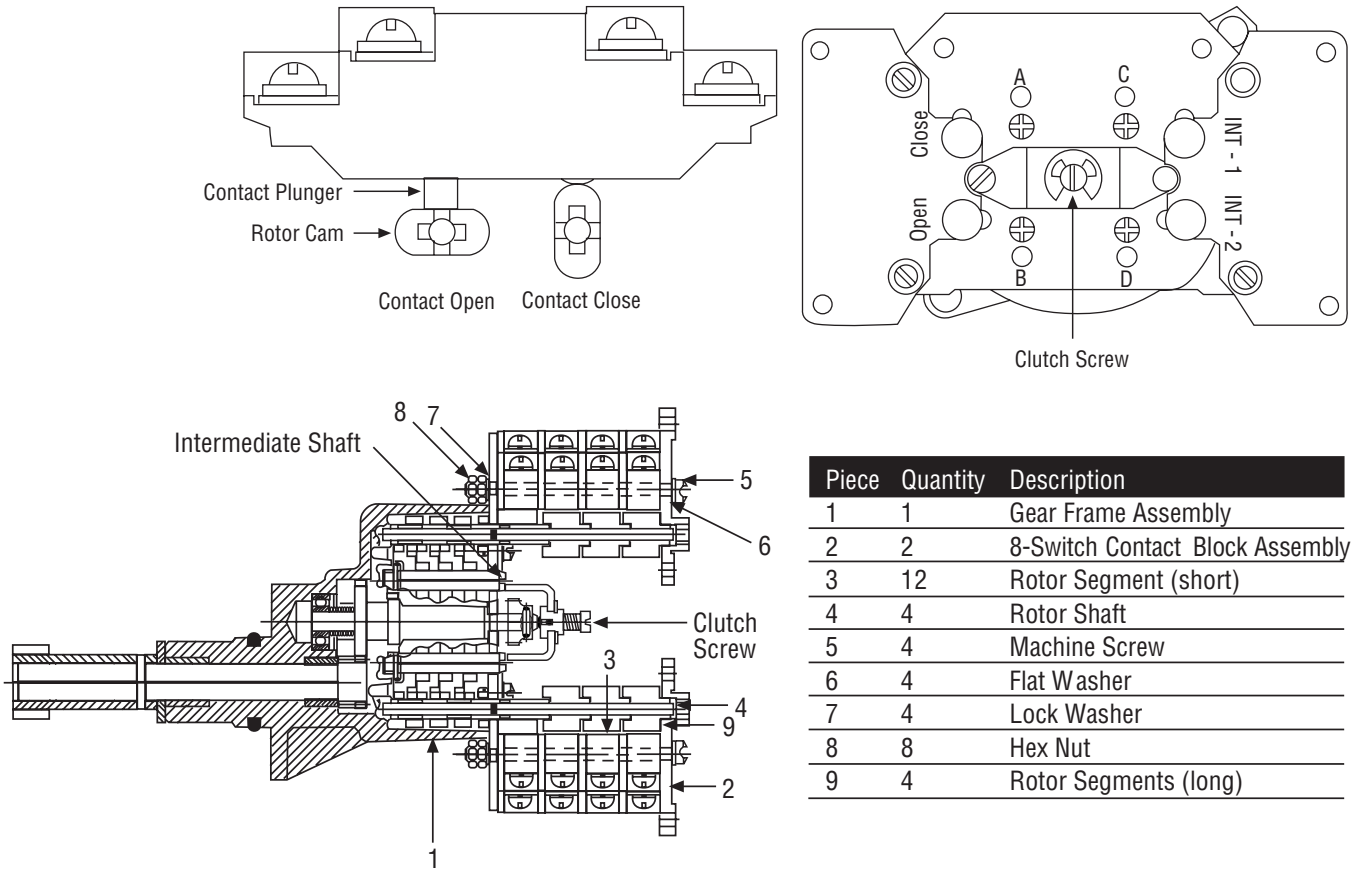

Unless otherwise noted part numbers refer to Figure 4.5.

1. Open the Limit Switch Compartment Cover (piece #200-1 of Figure 7.3 for L120-190 and -420, Figure 7.6 for L120-800, and Figure 7.7 for L120-2000).
2. Put the actuator into manual operation. Use the handwheel to operate the valve in the “open” direction. While operating the valve, note the direction of rotation of the Intermediate Shaft corresponding to the rotor or rotors to be set.
3. When the valve is fully open, close it one turn of the handwheel to allow for coast of moving parts.
4. Push in the Clutch Screw and turn one-quarter turn. The rod will latch in this depressed position.
5. Refer to the applicable wiring diagram for contact development. The limit switch contact is closed when the rotor is engaged with the plunger. If the rotor to be set has not turned 90° to operate the plunger, turn the intermediate shaft in the same direction as noted in Step No. 2 until the rotor clearly trips the switches. This rotor is now set correctly.
6. If the intermediate position rotors 1 and 2 are also to be set at any desired position, repeat the setting operation in steps 1 through 5 above.
7. Before moving the valve, depress and turn the Clutch Screw counterclockwise one-quarter turn to the spring-released position. Insert a screwdriver into the intermediate shafts to ensure that they are loaded in position and will not rotate.

NOTE: The cross-slotted shafts A, B, C, and D have been designed for use with a No. 2 Phillips screwdriver shank chucked into a variable speed reversible electrical drill. Do not run drill at speeds higher than 200 RPM (see previous CAUTION on page 16).

▲ CAUTION: Do not operate the valve when the Clutch Screw is in a fully depressed position. Loss of contact setting will occur and the setting rod will be damaged.

8. Operate the valve by handwheel to the fully “close” position; reverse direction by one turn of the handwheel to remove backlash from gear components.
9. Set the other rotors by following steps 1 through 7.
10. Secure the Limit Switch Compartment Cover (piece #200-1 of Figure 7.3 for L120-190 and -420, Figure 7.6 for L120-800, and Figure 7.7 for L120-2000).

NOTE: For actuators having captive bolts, pull-down torque must not exceed 30 ft lbs.

4.5.2 Combination of Contacts

Refer to Figure 4.5.

The rotor segments can be separated and rotated through 90° to give various combinations of normally open or normally closed contacts to each rotor.

1. Remove Nuts (piece #8) and Fillister Head Machine Screws (piece #5) for a total of two fasteners on each side of the switch.
2. Remove complete contact assembly from the back plate.
3. Rearrange cams on the camshaft to produce the required combination of contacts.
4. Replace contact assembly on back-plate (ensuring the registers fit correctly) and secure with the machine screws and nuts.

4.6 Position Indication

4.6.1 Local Position Indication

The local dial position indicator is factory-built per the application. The position indicator can only be adjusted when mounted on the valve.

Figure 4.6 – Position Indicators

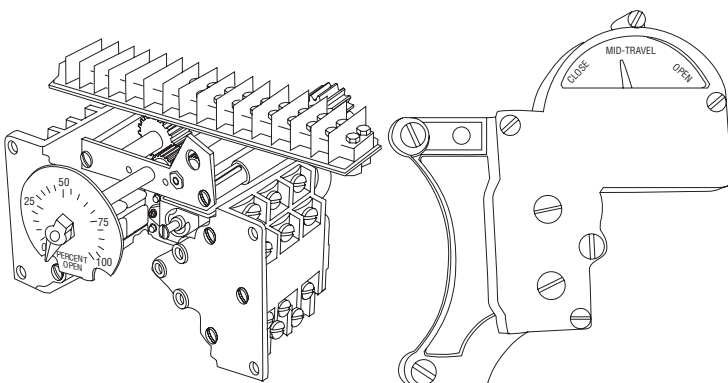

NOTE: See the setting procedure on the following page.

To set the local position indicator:

1. Disconnect all incoming power and remove Limit Switch Compartment Cover (piece #200-1 of Figure 7.3 for L120-190, -420 and -800, and Figure 7.7 for L120-2000).
2. Using the handwheel place the valve in the fully “close” position.
3. Loosen the round head machine screw which holds the pointer in place; move the pointer to the “0” position, and re-tighten the screw.

The indicator is now set.

NOTE: The end-of-travel rotors of the geared limit switch activate “flip-flop” type indicators. This type of indicator will require no further setting after the geared limit switch has been adjusted.

4.6.2 Remote Position Indication

The remote position indicator is a Limitorque digital position indicator. This indicator is a digital LED display module that displays valve position in 1% increments. The readout accepts inputs from signals of 4-20 mA, 0-2 V, or a 1000 ohm feedback potentiometer (mounted on the MDPI). The readout is accurate to 1% +/- 1 digit.

4.6.3 Calibrating Position Transmitter PT20SD

1. Position the actuator to mid-travel value at 50% position.
2. Disconnect the potentiometer wiring harness from the PT20SD board and measure the resistance from each end connection to the center connection on the potentiometer.
3. Set the potentiometer to the correct resistance reading. Loosen the setscrew that retains the spur gear on the potentiometer shaft and rotate the shaft until a reading of 500 ohms is achieved.
4. Tighten the setscrew and reconnect the wiring harness to the PT20SD.
5. Run the actuator fully CLOSED.
6. Calibrate ZERO position by adjusting the zero potentiometer until a 4mA output signal is read at terminal +Ve and -Ve.
7. Run the actuator fully OPEN.
8. Calibrate SPAN position by adjusting the span potentiometer until a 20mA output signal is read at terminals +Ve and -Ve.
9. Repeat steps 5 through 8 and fine-tune as necessary.

Figure 4.7 – Typical Connection for a 1000 ohm Potentiometer

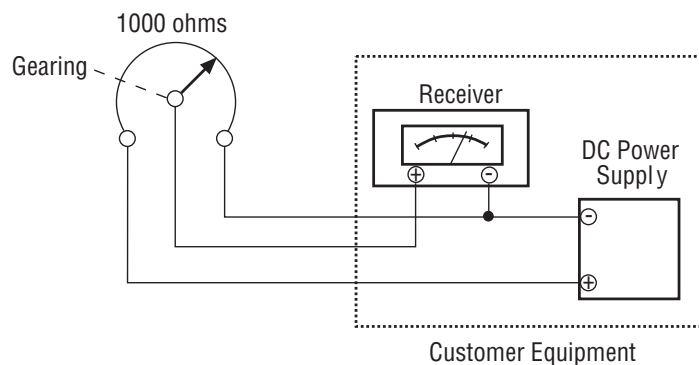

5 Operation

⚠ **WARNING:** See Sections 4.1 and 4.2 Safety Precautions and Safety Practices.

⚠ **WARNING:** Do not manually operate the actuator with devices other than the installed Handwheel and Declutch Lever. Using force beyond the ratings of the actuator and/or using additive force devices such as cheater bars, wheel wrenches, pipe wrenches or other devices on the actuator Handwheel or Declutch Lever may cause serious personal injury and/or damage to the actuator or valve.

⚠ **CAUTION:** Do not motor-operate the valve without first setting or checking the limit switch setting and motor direction. If the valve closes when the open button is pushed, the motor may need to be electrically reversed.

- Do not force the declutch lever into hand operation. If the clutch does not easily engage, rotate handwheel slowly while operating the declutch lever.
- Do not force the declutch lever into motor operation position. Lever returns to this position automatically when motor is energized.
- Do not run “plug” type valve against stop.
- Do not alternately start/stop the motor to open or close a valve that is too tight for normal operation.

5.1 Electrical Start-Up

1. Verify that the actuator has been correctly lubricated. This is particularly important if the actuator has been in long-term storage.
2. Verify that the geared limit switch has been correctly set per Section 4.5.1, Setting Limit Switch.
3. If the valve stem is not visible, remove the stem cover or handwheel cover plate to observe the output direction of the drive sleeve.
4. Engage manual operation and hand crank the valve well away from end-of-travel positions.
5. Turn on power supply and push the “open” button on the pushbutton station.

6. Check output rotation:

- If phase rotation is correct, the valve should begin to open.
- If valve begins to CLOSE, STOP IMMEDIATELY. Incorrect phase rotation will lead to serious damage if the valve seats.

NOTE: For actuators supplied with the UEC-3 electronics controls package, if the output rotation is incorrect, select the opposite direction via the dipswitch setting.

7. Correct the phase rotation one of two ways:

- switch any two of the three power leads for three-phase power, or
- reverse the armature leads for DC power.

The actuator should operate correctly and will be stopped at the end-of-travel positions by torque or limit switch functions.

Premature stopping may be caused by incorrect limit switch or torque switch settings or obstructions in the valve.

5.1.1 Typical Wiring Diagram

Figures 8.1 through 8.4 are representations of typical applications and may not be applicable to your specific actuator. Please refer to the wiring diagram supplied with your actuator to confirm the actual equipment supplied. Check www.limitorque.com for the latest diagram revisions and/or related diagrams.

5.2 Manual Operation

Piece numbers refer to Figures 7.1, 7.2, and 7.3 for L120-190 and -420, Figures 7.4, 7.5, and 7.6 for L120-800, and Figures 7.7 - 7.10 for L120-2000.

The actuator has a handwheel for manual operation. The actuator may be manually operated any time the motor is not engaged.

Manually operate as follows:

1. Move the Declutch Lever (piece #10, #11) in the direction of the arrow until it latches into place. Do not force the lever.
2. If the lever will not latch, rotate the Handwheel (piece #5) while turning the declutch lever and the lever will latch in place.

When the declutch lever is turned, it rotates a Cam which causes the Clutch Fork (piece #42-1) to move the Worm Shaft Clutch (piece #33) axially along the worm shaft against the force of a Clutch Spring (piece #45, #46). This disengages the mating lugs on the Worm Shaft Gear (piece #32) and the clutch, and engages the clutch with the Handwheel Gear (piece #17, #9). The Clutch Trippers (piece # 34-A and 34-B) maintain this position and latch onto the worm shaft gear. Turning the Handwheel (piece #5) rotates the Handwheel Shaft (piece #18) and the Handwheel Pinion. The handwheel pinion then drives the Handwheel Gear (piece #8, #9) which in turn drives the clutch. The clutch then drives the actuator in the same manner as in motor operation.

When the motor is energized, the motor pinion will turn the worm shaft gear. Tripper cams mounted on the worm shaft gear cause the trippers to release the clutch. The Clutch Fork (piece #42-1) is then forced, under spring pressure, to return the clutch to the motor operation position.

NOTE: The shift from manual operation to motor operation is automatic and does not require external positioning of the declutch shaft.

5.3 Motor Operation

The actuator is always available for motor operation whenever the motor is energized.

▲ CAUTION: Do not force the declutch lever into motor operation. Lever will automatically return to motor operation when the motor is energized.

Reset the travel limit switches prior to motor operation if the actuator has been dismantled or removed from the valve. Piece numbers refer to Figures 7.1, 7.2, and 7.3 for L120-190 and -420, and Figures 7.4, 7.5, and 7.6 for L120-800.

In motor operation, the Motor Pinion (piece #31) drives the Worm Shaft Gear (piece #32), which drives the Worm Shaft Clutch (piece #33) through the clutch lugs on both the worm shaft gear and the clutch. The Worm Shaft (piece #17) is driven by splines on the OD of the worm shaft and on the ID of the clutch. The worm shaft is splined to the Worm (piece #30-1) which drives the Worm Gear (piece #13).

Two lugs on the worm gear are engaged by matching grooves in the Drive Sleeve (piece #8). This arrangement provides the no-lost-motion mode of operation and allows the worm gear to turn the drive sleeve. The worm gear lugs may also be oriented outside the grooves to give the lost-motion or hammerblow effect. The Stem Nut (piece #12) is rotated by internal splines on the ID of the drive sleeve and external splines on the OD of the stem nut. This causes a threaded stem to translate in a threaded stem nut and a keyed shaft to rotate in a keyed stem nut. Thrust is absorbed by Bearings (piece #40, #41, #14, and #67) located at the top and bottom of the drive sleeve.

5.4 Torque and Travel Limiting

Unless otherwise stated, piece numbers refer to Figures 7.1, 7.2, and 7.3 for L120-190 and -420, and Figures 7.4, 7.5, and 7.6 for L120-800.

The Geared Limit Switch (piece #305 of Figure 7.6) is driven directly by the worm shaft gear through the limit switch pinion. Thus, the limit switch is directly connected to the output of the actuator and, once properly set, remains in step with the valve position regardless of the electric or manual operation of the actuator.

As the actuator increases torque, the worm and the Torque Spring Cartridge Assembly (composed of piece #'s 16-1 through 16-8) move axially along the worm shaft, compressing the disk spring packs. The torque spring assembly is calibrated such that a finite spring compression relates to a finite output torque. Axial worm movement causes movement of the bearing cartridge that is geared to the Torque Switch (piece #300). The torque switch is graduated and adjustable so it may be set to interrupt power to the motor at a predetermined output torque level.

6

Maintenance

6.1 Lubrication

The L120 series actuators have a totally sealed gear case, factory-lubricated with grease. The gear case can be mounted in any position.

▲ CAUTION: When the actuator is mounted in an upside-down orientation, the worm may not be completely immersed in lubricant. Check lubricant levels before operating the actuator.

No seal can remain absolutely tight at all times. Therefore, it is not unusual to find a very small amount of weeping around shaft seals—especially during long periods of idleness such as storage. Using grease minimizes this condition as much as possible. If a small amount of lubricant is weeping at start-up, remove it with a clean cloth. Once the equipment is operating on a regular basis, the weeping should stop.

6.1.1 Lubrication Inspection

Inspect Limitorque L120 series actuators for correct lubrication prior to operating—particularly following a long storage period.

Each application has its own effect on the actuator. The frequency of these inspections should be based on the application and the operating experience. The following lubrication inspection schedule is recommended until operating experience indicates otherwise.

For Gear Case, inspect lubrication every 18 months or 500 cycles, whichever occurs first.

During an inspection, consider the following:

- Quantity – Ensure there is enough lubricant so that the Worm and the Worm Gear are totally immersed in grease regardless of the position.
- Quality – Inspect lubricant for dirt, water or other foreign matter. If any one of these is found:
 1. Flush the actuator with a commercial degreaser/cleaner such as Exxon Varsol #18. This degreaser/cleaner is not corrosive and does not affect the seal materials.
 2. Repack the actuator with fresh lubricant, allowing room for grease thermal expansion.

- Consistency – Ensure the lubricant is fluid approximating a standard NLGI-0 grade consistency or less. Thinners such as Amoco WAYTAC #31 oil may be added provided the volume of thinner does not exceed 20% of the total lubricant.

6.1.2 Factory Lubricant

Gear Case

- The L120-190 through 2000 is factory-lubricated with an NLGI Grade 00 lithium-base grease, suitable for temperatures from 0°F to 225°F (-18°C to 107°C).

Geared Limit Switch

- Mobil 28 (No Substitute)

Table 6.1 – Lubricant Weights

Actuator Size	lb.	kg
L120-190	15	5.6
L120-420	50	18.7
L120-800 Drive 1	71	26.5
L120-800 Drive 2	75	28
L120-2000 Drive 1	65	24.3
L120-2000 Drive 2	72	26.9

Minimum Lubricant Qualities Required

The standard lubricants used by Limitorque have been proven to be extremely reliable over years of service. Limitorque does not recommend a particular lubricant substitute for the standard lubricants; however, Limitorque does require the following lubricant qualities as a minimum.

- ▲ **CAUTION:** Do not mix lubricants of a different base chemical. Mixing lubricant bases may cause lubricant properties to be ineffective.

The lubricant must:

- Contain an “EP” additive.
- Be suitable for the temperature range intended.
- Be water and heat-resistant and non-separating.
- Not create more than 8% swell in Buna N or Viton.
- Not contain any grit, abrasive, or fillers.
- Comply with a slump-prefer NLGI-00 grade.
- Not be corrosive to steel gears, ball, or roller bearings.
- Have a dropping point above 316°F (158°C) for temperature ranges of 0°F to 225°F (-18°C to 107°C).

7

Disassembly and Reassembly

⚠ **WARNING:** See sections 4.1 and 4.2 Safety Precautions and Safety Practices prior to disassembly.

⚠ **WARNING:** Potential High Pressure Vessel. Before removing or disassembling your actuator, ensure that the valve or other actuated device is isolated and is not under pressure.

⚠ **CAUTION:** Turn off all power services before attempting to perform service on the actuator.

NOTE: Remove the actuator from the valve for complex work. Minor work, such as replacing geared limit switch, torque switch or motor, may be readily performed while the actuator is still on the valve.

7.1 L120-190, -420, and -800

⚠ **WARNING:** See sections 4.1 and 4.2 Safety Precautions and Safety Practices prior to disassembly.

NOTE: The disassembly of the actuator L120-190 will be used as a general example. Always refer to the parts drawing when disassembling. Be certain to keep all parts clean and free from dirt after disassembly.

NOTE: Unless otherwise noted, piece numbers refer to Figures 7.1, 7.2 and 7.3 for L120-190 and -420, and Figures 7.4, 7.5 and 7.6 for L120-800.

7.1.1 To Replace Stem Nut Only

⚠ **WARNING:** Do not remove Locknut (piece #39) with actuator under load or with valve under pressure. See Warning on Step No. 11 of Section 7.1.2 L120-190, 420, 800 Disassembly.

NOTE: If the valve must be left in service while the stem nut is replaced, the valve stem must be locked in such a way as to prevent any movement of the valve stem.

Piece numbers refer to Figures 7.1, 7.2 and 7.3 for L120-190 and -420, and Figures 7.4, 7.5 and 876 for L120-800.

If the Stem Nut (piece #12) is to be removed from the assembled actuator, remove the Lock Nut (piece #39) and lift out top of nut.

1. The Lock Nut (piece #39) is staked in two places. Locate the stakes and spot with a drill.
2. Clean all metal particles and remove.
3. If the actuator is mounted on a valve having a threaded stem, and removal of the stem nut is required, perform Step No.1 and rotate the handwheel to close the valve.
4. The stem nut will rise up the threaded valve stem. When the stem nut splines are free from the drive sleeve, rotate the stem nut by hand the remaining length of the valve stem.
5. Replace if necessary.
6. Install the new stem nut with the lock nut.
7. Stake the top threads of the lock nut in two places.

7.1.2 L120-190, 420, 800 Disassembly

Piece numbers refer to Figures 7.1, 7.2 and 7.3 for L120-190 and -420, and Figures 7.4, 7.5 and 876 for L120-800.

1. Turn off power to the actuator.
2. Open or remove electrical Compartment Cover (piece #200-1).
3. Disconnect all electrical leads from the Torque Switch (piece #300) and Geared Limit Switch (piece #305). Ensure that all leads and terminals are clearly marked to facilitate reassembly.
4. Remove two screws holding limit switch and one holding torque switch. Remove both items.
5. Remove four bolts holding Motor (piece #124) and three bolts holding conduit Nipple Flange (piece #26). Remove motor, drawing motor leads through the conduit opening.
6. Replace Motor Pinion (piece #31). The motor pinion is keyed to the motor shaft and held there with a setscrew and lockwire to retain the pinion in its proper position. The motor pinion should be shouldered on the motor shaft.
7. Remove Handwheel (piece #5) by loosening setscrew. Handwheel can then be pulled from Handwheel Shaft (piece #18).
8. Remove Declutch Lever Subassembly (piece #11) by removing Extension Spring (piece #48), Retaining Ring (piece #53-4), Declutch Link (piece #10), and two hex head cap screws holding the subassembly in place. Remove subassembly.
9. Remove Spring Cartridge Cap (piece #4).
10. Remove Worm and Torque Spring Subassembly (piece #13, #30-1) completely. Temporarily replace the handwheel and then rotate in the close direction to cause the worm to screw out of engagement with worm gear and cause the torque spring cartridge to emerge from Housing (piece #1). See Step No. 21 to further disassemble the cartridge.
11. Remove Housing Cover (piece #3).

- ⚠ **WARNING:** Do not remove if a thrust load is on the actuator or if the valve is under pressure and not fully open, as personal injury may result.
- 12. Lift complete drive sleeve assembly from actuator housing. The drive sleeve assembly consists of Lock Nut (piece #39), Stem Nut (piece #12), Drive Sleeve (piece #8), Upper Thrust Bearings (piece #40, #67), Worm Gear (piece #13), Worm Gear Spacer (piece #36) and Lower Thrust Bearing (piece #14). The drive sleeve assembly may be further dismantled if required by pressing off Lower Drive Sleeve Bearing (piece #41).
- 13. Remove Retaining Ring (piece #53-1), Split Ring Retainer (piece #27) and Conduit Nipple (piece #26). Pull the Worm Shaft Clutch Gear (piece #32) from the worm shaft.
- 14. Spread clutch trippers with a tool to shift actuator into motor operation.
- ⚠ **WARNING:** Do not use hands as spring forces could result in personal injury.
- 15. Remove bolts holding Declutch Housing (piece #2) to Housing (piece #1). Remove clutch housing, Trippers (piece #34-A and #34-B), and Clutch Fork Assembly (piece #42-1). Worm Shaft Clutch (piece #33) will slide off worm shaft when removing clutch housing.
- 16. Slide Clutch Spring (piece #45) off worm shaft toward motor end.
- 17. Remove Elastic Stop Nut (piece #16-7). Pull Handwheel Spur Gear (piece #9) that is keyed to Shaft (piece #17).
- 18. Remove bolts holding WS Bearing Cap (piece #7) and slide cap off wormshaft. Remove Handwheel Clutch Pinion (piece #20) from bearing cap by removing Retaining Ring (piece #53-3). Be careful not to lose Handwheel Pinion Spring (piece #47) and Spring Ring (piece #49).
- 19. Remove Handwheel shaft: tap on the motor end of the shaft to free Ball Bearing (piece #52-1) from housing. Handwheel shaft will break free from Ball Bearing (piece #52-6). Remove handwheel shaft from housing.
- 20. Withdraw handwheel shaft from handwheel end of housing.
- 21. To disassemble worm assembly further (removed in Step No. 10), remove Elastic Stop Nut (piece #16-7), **noting the number of turns to remove.**
- 22. Remove Thrust Washers (piece #16-2), Limit Sleeve (piece #16-5), and Belleville Disc Springs (piece #16-3 and #16-4). Note the orientation of the discs for reassembly later.
- 23. Remove Retaining Ring (piece #53-4).
- 24. The Bearing Cartridge (piece #16-1) and Worm Subassembly (piece #30-1) can now be withdrawn.
- 25. Remove the Ball Bearing (piece #52-7), locate setscrew in bearing locknut and remove setscrew and Locknut (piece #44-1).

7.1.3 Reassembling Actuator Sizes L120-190, -420 and -800

1. Follow the disassembly instruction for Actuator Sizes 190, 420, and 800 in the reverse order and follow the gasketing instructions below.
2. Stack Belleville disc, thrust washers, and spacers that were removed in the exact order as they were removed.
3. Re-install Elastic Stop Nut (piece #16-7) with the same number of turns used to remove.

4. For the Worm Shaft Clutch (piece #33), install the clutch with smaller set of lugs first to engage with lugs on Handwheel Clutch Pinion (piece #20).
5. For worm, rotate Worm Shaft Clutch (piece #33) to engage splines on worm shaft. Place actuator in manual operation, replace Declutch Lever Subassembly (piece #11), and handwheel temporarily; rotate handwheel in opposite direction used to remove worm.
6. When re-installing the Motor Pinion (piece #31), ensure it fits tightly on the motor shaft (preferably a light press fit).

7.1.4 Gaskets

All gaskets, except the housing cover gaskets, are 1/32" thick Anchorite. The housing cover gaskets vary in thickness. Determine the correct size as follows:

1. Clean both housing cover and main housing gasketed surface.
2. Install actuator drive sleeve assembly complete with bearings.
3. Install housing cover and measure the gap between the housing cover and the main housing.
4. Add 10% to the measurement. Use the closest nominal gasket thickness or combination available.

Figure 7.1 – L120-190 and -420 Drive Sleeve Side View (Refer to Table 7.1 for parts list)

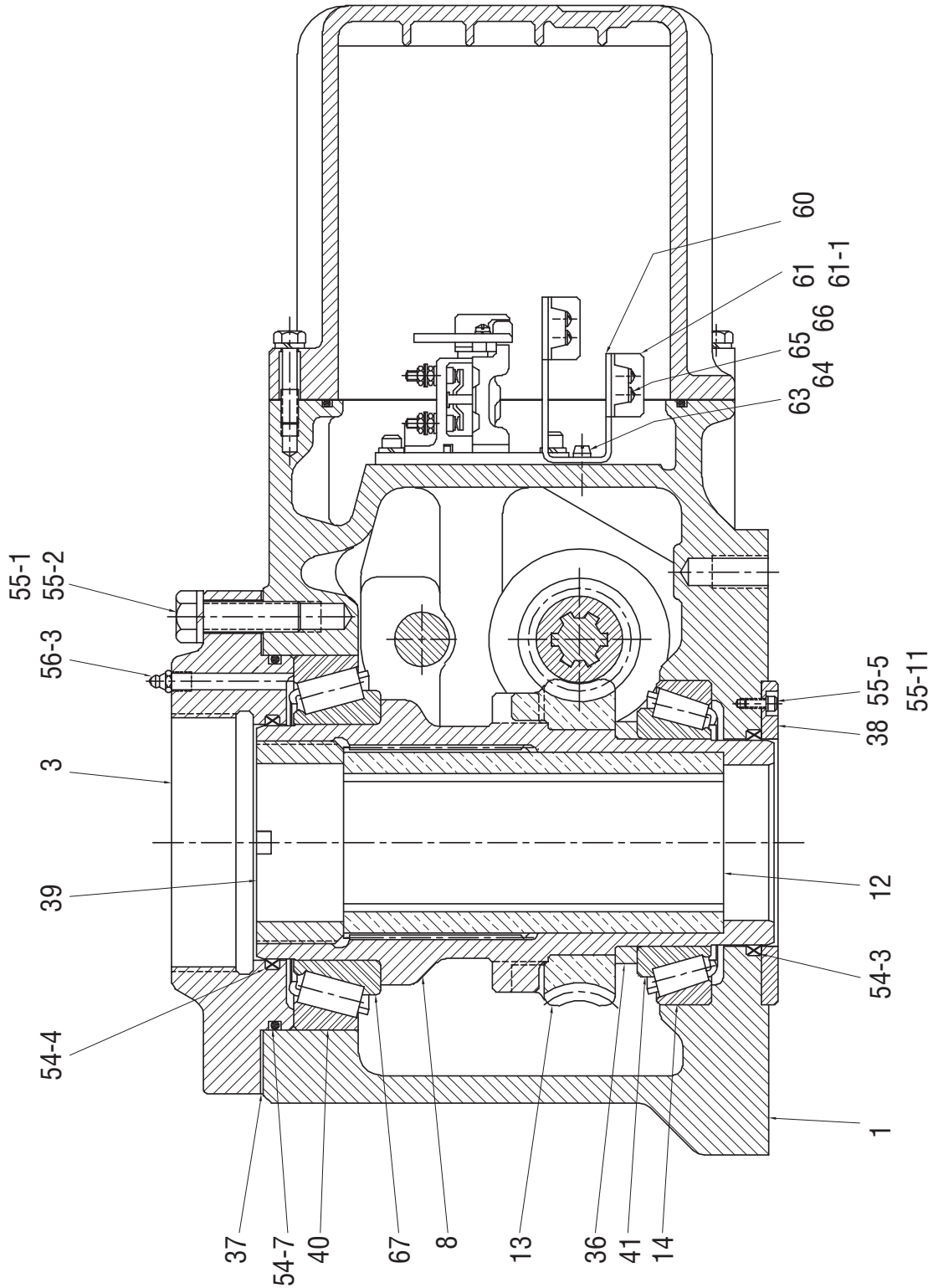
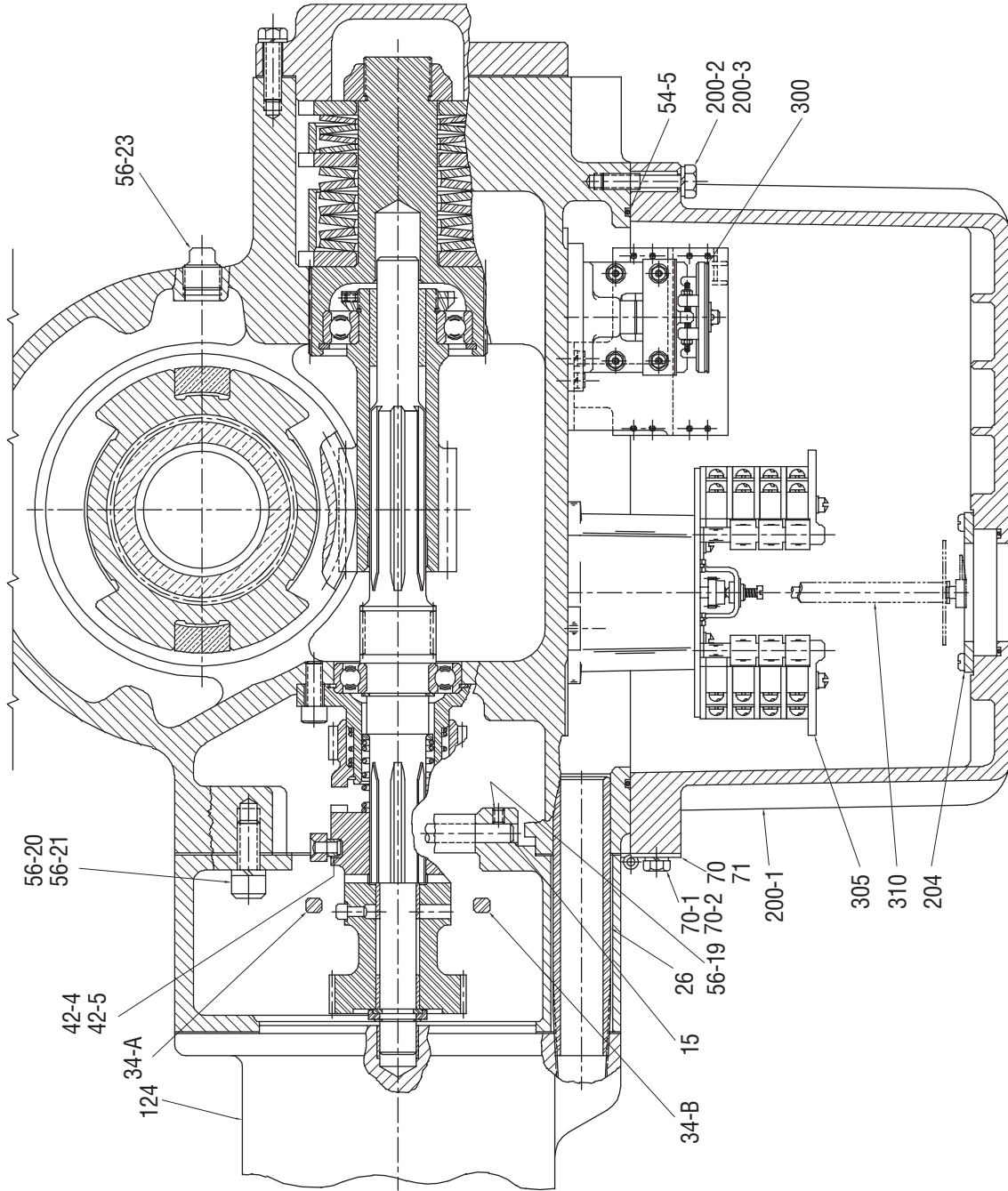
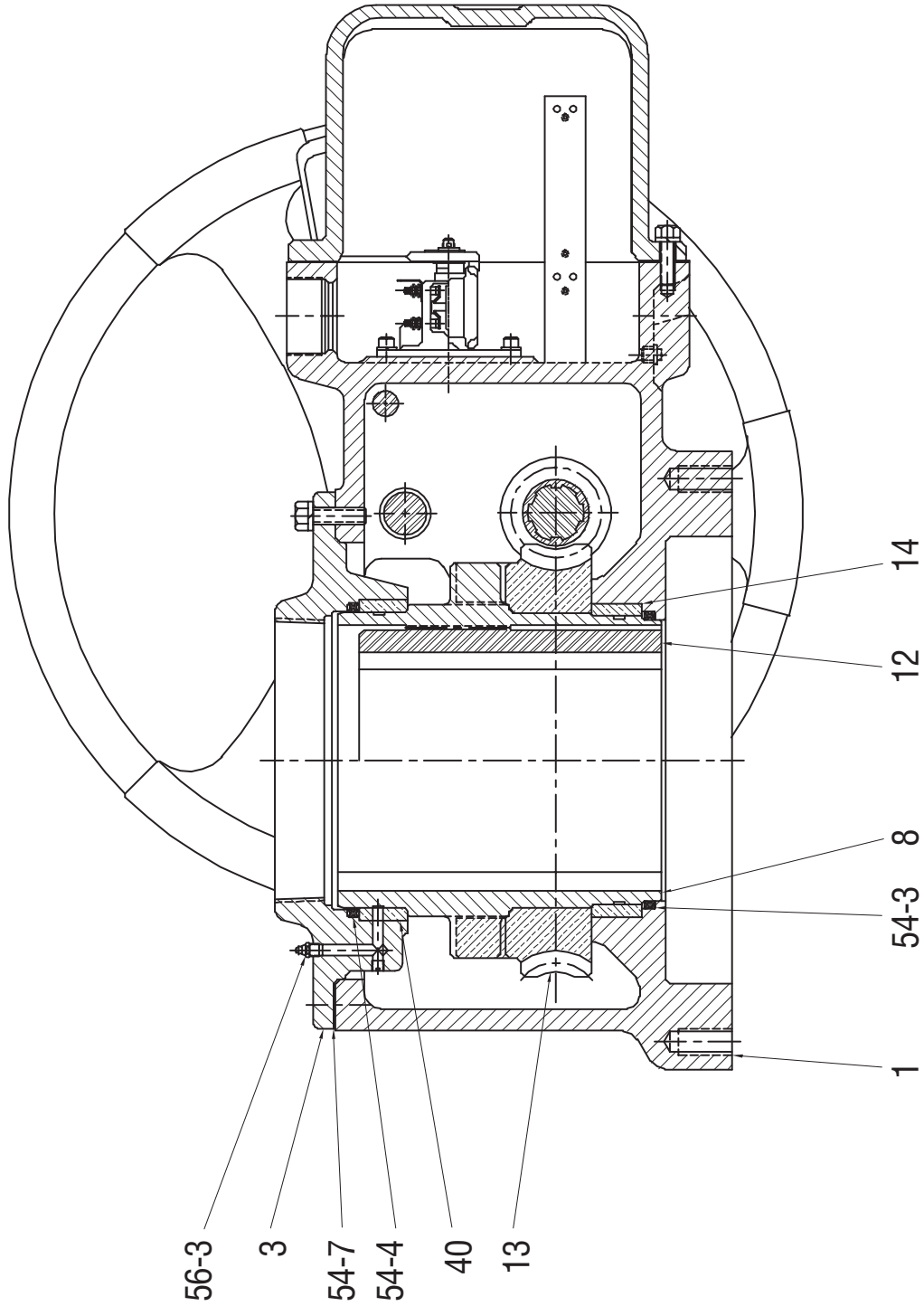

Figure 7.3 – L120-190 and -420 Top View (Refer to Table 7.1 for parts list)



Drawing 01-608-0117-4

Figure 7.4 – L120-800 Drive Sleeve Side View (Refer to Table 7.1 for parts list)



Drawing 01-608-0138-4

Figure 7.5 – L120-800 Worm Shaft Side View (Refer to Table 7.1 for parts list)

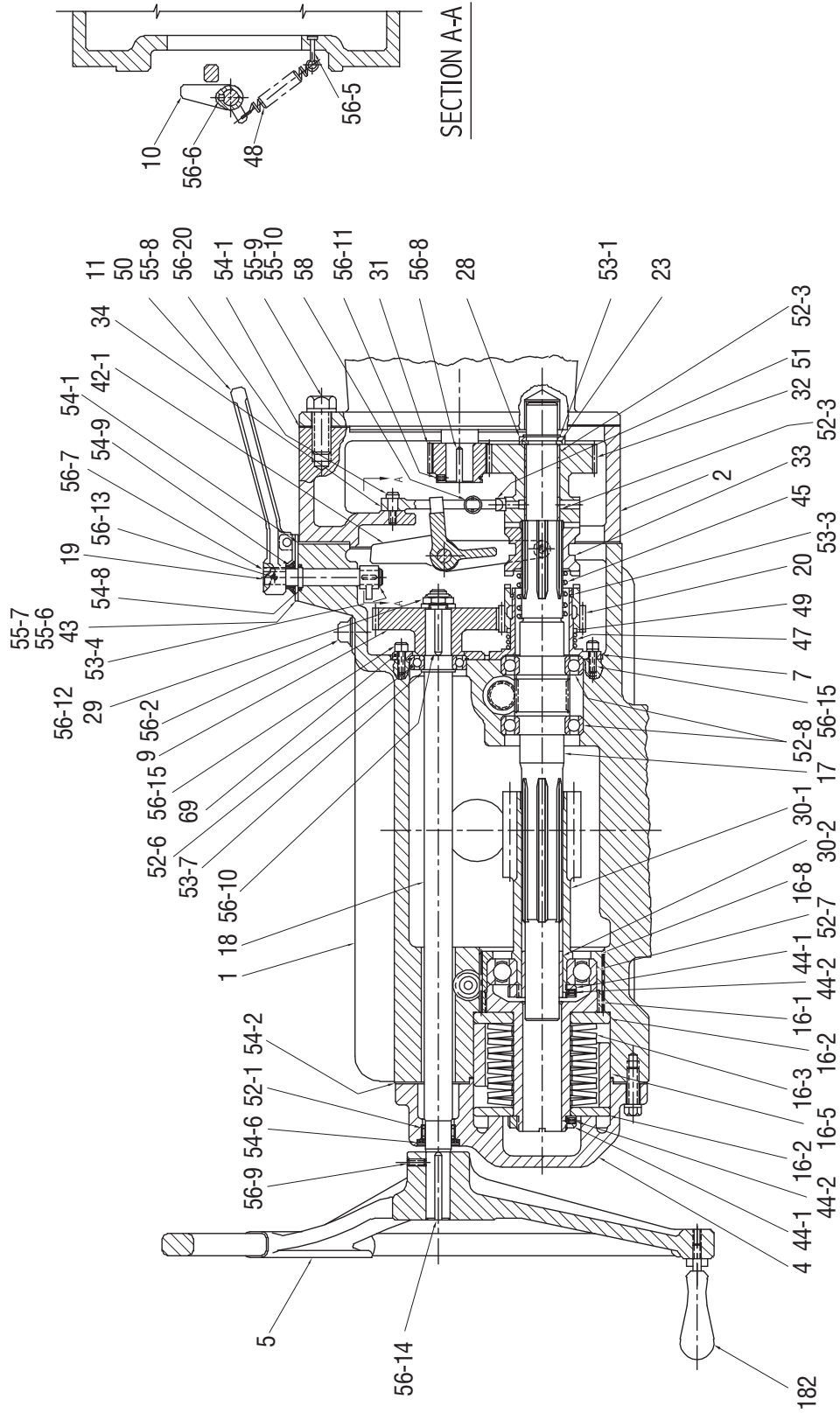

Table 7.1 – L120-190, -420 and -800 typical parts list

Piece No.	Quantity	Description
1	1	Housing
2	1	Declutch Housing
3	1	Housing Cover
4	1	Spring Cartridge Cap
5	1	Handwheel
6	1	Limit Switch Compartment Cover (L120-800 only)
6-1	1	Hex Head Cap Screw (L120-800 only)
6-2	1	Lockwasher (L120-800 only)
7	1	Worm Shaft Bearing Cap (L120-420, 800)
8	1	Drive Sleeve (2 pc)
9	1	Handwheel Spur Gear
10	1	Declutch Link
11	1	Declutch Lever
12	1	Stem Nut
13	1	Worm Gear
14	1	Lower Thrust Bearing Cup
15	1	Fork Pivot Pin (L120-420, 800)
16-1	1	Bearing Cartridge
16-2	various	Thrust Washer
16-3	various	Belleville Spring
16-4	various	Belleville Spring
16-5	1	Torque Limit Sleeve
16-6	1	Torque Limit Sleeve
16-7	1	Elastic Stop Nut (L120-190 only)
16-8	1	Bearing Cartridge Stem (L120-420, 800)
17	1	Worm Shaft
18	1	Handwheel Shaft
19	1	Declutch Shaft
20	1	Handwheel Clutch Pinion
23	1	Split Ring
26	1	Motor Conduit Nipple
27	1	Split Ring Retainer
28	1	Lock Nut
29	1	Worm Bushing
30-1	1	Worm
31	1	Motor Pinion
32	1	Worm Shaft Gear
33	1	Worm Shaft Clutch
34-A	1	Clutch Tripper #1
34-B	1	Clutch Tripper #2
35	1	Spring Spacer
36	1	Worm Gear Spacer
37	1	Housing Cover Shim Set

Piece No.	Quantity	Description
38	1	Seal Retainer Plate
39	1	Lock Nut
40	1	Upper Thrust Bearing Cup
41	1	Lower Thrust Bearing Cone
42-1	1	Declutch Fork
42-4	2	Fork Roller (L120-420, 800)
42-5	2	Fork Roller Pin (L120-420, 800)
43	1	Declutch Lever Plate
44-1	1	Lock Nut
44-2	1	Set Screw
45	1	Clutch Spring
46	1	Handwheel Shaft Spacer
47	1	Handwheel Pinion Spring
48	1	Extension Spring
49	1	Spring Ring
50	1	Declutch Lever Nameplate
51	1	Worm Shaft Gear Cam Pin
52-1	1	Ball Bearing (L120-190)
52-1	1	Bushing (L120-420, 800)
52-3	2	Motor Clutch Gear Bushing
52-6	1	Ball Bearing
52-7	1	Ball Bearing
52-8	2	Ball Bearing
53-1	1	Retaining Ring
53-2	1	Retaining Ring
53-3	1	Retaining Ring
53-4	1	Retaining Ring
53-5	1	Retaining Ring
53-7	1	Retaining Ring
53-8	1	Retaining Ring (L120-190 only)
54-1	2	Declutch Housing Gasket
54-2	1	Spring Cartridge Cap Gasket
54-3	1	Quad Ring
54-4	1	Quad Ring
54-5	1	O-Ring
54-6	1	O-Ring (L120-190)
54-6	1	Oil Seal (L120-420, 800)
54-7	1	O-Ring (L120-190)
54-7	1	Gasket (L120-420, 800)
54-8	1	O-Ring
54-9	1	Chekseal
55-1	12	Hex Head Cap Screw
55-2	12	Lockwasher

Table 7.1 Continued – L120-190, -420 and -800 typical parts list

Piece No.	Quantity	Description
55-3	7	Hex Head Cap Screw
55-4	various	Lockwasher
55-5	2	Socket Head Cap Screw
55-6	various	Hex Head Cap Screw (L120-190, 420)
55-7	various	Lockwasher
55-8	2	Drive Screw
55-9	4	Hex Head Cap Screw
55-10	4	Lockwasher
55-11	2	Lockwasher (L120-190)
56-2	various	Pipe Plug
56-3	1	Grease Fitting
56-5	1	Clevis Pin
56-6	1	Key
56-7	1	Key
56-8	1	Key
56-9	1	Socket Head Set Screw
56-10	1	Key
56-11	1	Flat Washer (L120-190)
56-11	1	Socket Head Set Screw (L120-420, 800)
56-12	1	Flat Washer
56-13	1	Socket Head Set Screw
56-14	1	Key
56-15	various	Socket Head Cap Screw
56-18	various	Socket Head Cap Screw
56-19	1	Socket Head Set Screw
56-20	4	Socket Head Set Screw
56-21	4	Lockwasher

Piece No.	Quantity	Description
56-23	1	Pipe Plug
56-25	2	Dowel Pin (L120-420, 800)
57	1	O-Ring Spacer (L120-190)
58	1	Tripper Spring
60	1	Terminal Bracket
61	2	Terminal Strip
61-1	2	Kulka Insulator Strip
63	2	Fil HD Mach Screw
64	2	Lockwasher
65	8	RD HD Mach Screw
66	8	Lockwasher
67	1	Upper Thrust Bearing Cone
68	2	Fork Spacer (L120-420, 800)
69	1	Handwheel Bearing Cap (L120-420, 800)
70	1	Hinge
70-1	various	Hex Head Cap Screw
70-2	various	Lockwasher
71	1	Hinge Standard Compartment
124	1	Motor
182	1	Handwheel Spinner Kit
200-1	1	Limit Switch Compartment Cover (L120-190, 420)
200-2	various	Hex Head Cap Screw (L120-190, 420)
200-3	various	Lockwasher (L120-190, 420)
204	1	M.D.P.I. Sight Glass
300	1	Torque Switch
305	1	Geared Limit Switch
310	1	Mechanical Dial Position Indicator

7.2 L120-2000

⚠ **WARNING:** See sections 4.1 and 4.2 Safety Precautions and Safety Practices.

NOTE: The L120-2000 Drive 2 is a thrust-type actuator consisting of an L120-2000 Drive 1 torque-type actuator mounted on a thrust bearing assembly. For torque-only actuators see Section 8.2.2, Drive 1 Disassembly (Torque Housing).

NOTE: Piece numbers refer to Figures 8.7 - 8.10.

7.2.1 Drive 2 Disassembly (Thrust Housing Only)

⚠ **WARNING:** Before proceeding, ensure that the actuator is not under load and that the valve is not under pressure. If so, the valve must be in fully open position.

Remove Drive Sleeve Locknut (piece #130):

1. Rotate handwheel to close valve, causing the Stem Nut (piece #127) to rise up threaded valve stem until the stem nut splines are free of Drive Sleeve (piece #126).
2. Rotate stem nut by hand for the remaining length of the valve stem and remove.

Remove Thrust Adapter (piece #125):

NOTE: If disassembly of thrust adapter assembly is not required, continue to Section 8.2.2, Drive 1 (Torque Actuator), Step No. 1.

1. Remove Seal Retainer Plate (piece #129) and Oil Seal (piece #54-6).
2. Loosen setscrew and remove Thrust Bearing Cartridge (piece #128) from the Thrust Adapter Housing (piece #125).
3. Remove Upper Bearing Roller Assembly (piece #131).
4. Lift Thrust Drive Sleeve (piece #126) out of Thrust Adapter Housing (piece #125).
5. Remove Lower Bearing Roller Assembly (piece #131).

7.2.2 Drive 1 Disassembly (Torque Housing)

1. Remove Limit Switch Compartment (piece #200-1).
2. Disconnect motor leads, Torque Switch (piece #301) leads, and Geared Limit Switch (piece #305) leads.

NOTE: Ensure leads are labeled for reassembly.

3. Remove screws holding Limit Switch and holding Torque Switch. Remove both items.
4. Remove bolts holding Motor.
5. Remove Motor Adapter (piece #22) and Motor Adapter Gasket (piece #105). Remove motor gear shims from the motor adapter bearing bores and store in a safe place.
6. Remove Intermediate Pinion (piece #32-1) and the Drive Shaft Gear (piece #32-2).
7. Remove torque switch and geared limit switch.

8. Using lifting eyebolts, remove Housing Cover (piece #3), Drive Sleeve (piece #8), and Worm Gear (piece #13).
9. Remove Handwheel Washer (piece #88). Pull off Handwheel (piece #5) and Handwheel Clutch (piece #83) from Handwheel Shaft (piece #18).
10. Remove Worm Shaft End Cap (piece #4) and Declutch Housing Cover (piece #86).
11. Remove Declutch Assembly:
 - A. Remove Declutch Lever Stop (piece #93), Tripper Spring (piece #58), Clutch Trippers (piece #34-A and #34-B) and Roll Pin (piece #19-7).
 - B. Loosen setscrews on Declutch Lever (piece #11) and Hallowell Collar (piece #56-8). Remove declutch lever, Declutch Shaft and Cap (piece #95), and slide Declutch Shaft (piece #19-1) out through bottom of actuator.
 - C. Remove Declutch Lever (piece #11), and other Declutch Shaft-Mounted Components (piece #19-2, #91, #92, and #56-8).
 - D. Remove Handwheel Shaft and Pinion (piece #18).
12. Remove Drive Shaft (piece #77) and Flexible Jaw Clutch (piece #82-1) as integral assembly. Remove Gear Clutch Spacer (piece #78), Sliding Gear Clutch (piece #33), and Clutch Compression Spring (piece #46).
13. Remove Splined Insert (piece #87) using jack screws. Remove Spirolox Ring (piece #53-3) and Handwheel Gear (piece #9).
14. Remove Gear Mounting Bracket (piece #84) using jack screws, Bearing (piece #52-7), and Bearing Adapter (piece #79).
15. Pull Hollow Drive Shaft (piece #17) toward declutch end and remove Spirolox Ring (piece #53-8).
16. Remove Declutch Housing (piece #2).
17. Remove Hollow Drive Shaft (piece #17):
 - A. Push hollow drive shaft toward motor end. Loosen setscrew and remove Bearing Locknut (piece #80-1) – hold hollow drive shaft using adjustable spanner on splines.
 - B. Remove Bearing (piece #52 -8) by pushing hollow drive shaft toward declutch end.
 - C. Remove Gear Limit Thread Collar (piece #76) and key.
 - D. Remove hollow drive shaft from declutch end of actuator.
18. Loosen setscrew in Cartridge Stem Locking Nut (piece #16-10) and replace Declutch Housing (piece #2) with two screws to compress torque spring.
19. Remove Locking Nut (piece #16-10).
- ▲ **CAUTION:** Declutch Housing is under spring load.
20. Remove Declutch Housing (piece #2):
 - A. Pull Bearing Cartridge Stem (piece #16-8) out partially.
 - B. Remove Thrust Washers (piece #16-2), Torque Limit Sleeve (piece #16-5) and Springs (piece #16-3).

21. Remove bearing cartridge/worm assembly from actuator. To disassemble further:
 - A. Loosen two setscrews on Bearing Cartridge Cap (piece #16-1), and unscrew Bearing Cartridge Stem (piece #16-8).
 - B. Slide bearing cartridge cap off toward worm threads.
 - C. Loosen setscrew and remove Bearing Locknut (piece #44-1).
 - D. Press off two Bearings (piece #73).

7.2.3 Drive 1 (Torque Housing) Reassembly

1. Press two Bearings (piece #73) onto worm. It may be necessary to apply heat to the bearings. Ensure that the bearing spacer is installed.
2. Install Bearing Lock Nut (piece #44-1) and tighten screw.
3. Apply head to Bearing Cartridge Cap (piece #16-1) and drop on bearing from worm end. Ensure that cartridge cap seats on bearing.
4. Install bearing cartridge/worm assembly in housing.
5. Replace the following in the order listed:
 - A. Thrust Washer (piece #16-2)
 - B. Belleville Springs (piece #16-3)
 - C. Torque Limit Sleeve (piece #16-5)
 - D. Thrust Washer (piece #16-2)

Ensure flat side of thrust washer is against springs.

6. Thread Cartridge Stem Nut (piece #16-10) onto Bearing Cartridge Stem (piece #16-8) by hand.
7. Slide bearing cartridge/worm assembly into housing.
8. Install Hollow Drive Shaft (piece #17).
9. Install Gear Limit Threaded Collar (piece #76) and key on motor end of hollow drive shaft with threaded end toward worm.
10. Slide Bearing (piece #52-8) onto shaft.
11. Thread Bearing Locknut (piece #81-1) on shaft and tighten setscrew. Hold Drive Shaft using adjustable spanner on splines.
12. Re-install motor as follows:
 - A. Push Hollow Drive Shaft (piece #17) to declutch and install Bearing Spacer (piece #101).
 - B. Install motor gearing by meshing Drive Shaft Gear (piece #32-2) and Intermediate Pinion (piece #32-1) and pressing combined assembly into housing bores.
 - C. Install motor gear shims in motor adapter bearing bores and install Motor Adapter Gasket (piece #105) and Motor Adapter (piece #22). Tap adapter to ensure bearings seat.
 - D. Check intermediate pinion and shaft for proper shims.
 - E. Install motor.

13. Re-install declutch housing as follows:
 - A. Install Spirolox Ring (piece #53-8) on Hollow Drive Shaft (piece #17).
 - B. Install Declutch Housing (piece #2) using two screws only to compress Belleville Spring Set (piece #16-3).
 - C. Using two screws, thread Cartridge Stem Nut (piece #16-10) on Bearing Cartridge Stem (piece #16-8) until nut is snug against Thrust Washer (piece #16-2).
 - D. Re-install declutch housing.
14. Install Bearing Mounting Bracket Assembly (piece #84, 79, and 52-7).
15. Install Handwheel Gear (piece #9) and Spirolox Ring (piece #53-8).
16. Install Splined Insert (piece #87), Spring Washer (piece #49) and Clutch Compression Spring (piece #46).
17. Install Sliding Gear Clutch (piece #33) onto Hollow Drive Shaft Splines (piece #17).
18. Install Drive Shaft (piece #77), ensuring that Gear Clutch Spacer (piece #78) is in place. Align splines on drive shaft and drive shaft gear and push drive shaft into actuator from declutch end.
19. Mount Bearing (piece #52-6 and #52-1) on Handwheel Shaft and Pinion (piece #18) and install assembly into actuator.
20. Install Declutch Shaft (piece #19-1) and Torsion Spring (piece #94) into Declutch Cap (piece #95).
21. Install declutch shaft assembly through bottom of Declutch Housing (piece #2). Declutch shaft assembly consists of:
 - Declutch Shaft
 - Declutch Shaft Washers (piece #91, 3 pieces)
 - Torsion Spring
 - Declutch Fork (piece #42-1)
 - Declutch Cap
 - Declutch Spacer (piece #92)
 - Declutch Lever Drum (piece #19-3)
 - Hollowell Collar (piece #56-8)
 - Declutch Arm (piece #19-2)

NOTE: Declutch shaft must be installed with key seat facing right side of the declutch housing when viewed from declutch end of actuator.
22. Fasten declutch cap.
23. Insert Roll Pin (piece #19-7) through declutch arm and shaft.
24. Ensure that declutch shaft bears against declutch cap, push collar against top of housing, and tighten collar setscrew.
25. Ensure that Oil Seal (piece #54-8) is in place.
26. Install Declutch Lever (piece #11) and tighten setscrew.
27. Rotate declutch lever clockwise, hold in position, and install Declutch Lever Stop (piece #93).

28. Install Clutch Tripper (piece #34-A, 34-B) and Tripper Spring (piece #58).
29. Install Declutch Housing Cover (piece #3) and Declutch Cover Gasket (piece #54-11).
30. Ensure that Handwheel Oil Seal (piece #54-8) is in place.
31. Install Worm Shaft End Cap (piece #4) and Worm Shaft End Cap Gaskets (piece #54-2).
NOTE: Ensure that the same number of gaskets is installed as were removed during disassembly. Thickness of gaskets must be sufficient to prevent end cap from bearing on drive shaft.
32. Install Worm Gear (piece #13).
33. Install Torque Drive Sleeve (piece #8) and Drive Sleeve Thrust Bearing (piece #40).
34. Apply fresh, clean lubricant in actuator housing. For quantity see Section 7.1, Lubrication.
35. Install Housing Cover Gasket (piece #54-7) and Housing Cover (piece #3).
36. Install Handwheel Clutch (piece #83), Handwheel (piece #5), and Handwheel Washer (piece #88) on Handwheel Shaft and Pinion (piece #18).
37. Install Torque Switch (piece #301) and Geared Limit Switch (piece #305).
38. Connect motor leads and leads to torque switch and geared limit switch.

7.2.4 Drive 2 (Thrust Housing Only) Reassembly

1. If Thrust Adapter Assembly (piece #125) is not disassembled, go to Step No. 7.
NOTE: Thrust bearing races should be pressed on Thrust Drive Sleeve (piece #126), in Thrust Adapter Housing (piece #125), and Thrust Bearing Cartridge (piece #128) prior to beginning assembly procedure.
2. Install Lower Bearing Roller Assembly (piece #131) in Thrust Adapter Housing (piece #125).
3. Install short end of Thrust Drive Sleeve (piece #126) into Thrust Adapter Housing (piece #125).
4. Install Upper Bearing Roller Assembly (piece #131) on the Thrust Drive Sleeve (piece #126).
5. Install Thrust Bearing Cartridge (piece #128), thread tight, or until drag is felt on thrust drive sleeve and tighten screw.
6. Install Oil Seal (piece #54-6) and Seal Retainer Plate (piece #129).
7. Lift actuator or turn upside down. Install Housing Thrust Adapter Assembly (piece #125). Ensure that Thrust Drive Sleeve O-Ring (piece #134) is in place.
8. Install Stem Nut (piece #127).
9. Install Drive Sleeve Locknut (piece #130) and crimp or stake the top threads to two places.
⚠ WARNING: Drive sleeve locknut has left-hand threads and must be rotated counterclockwise.

Figure 7.7 – L120-2000 Drive Sleeve Side View (Refer to Table 8.2 for parts list)

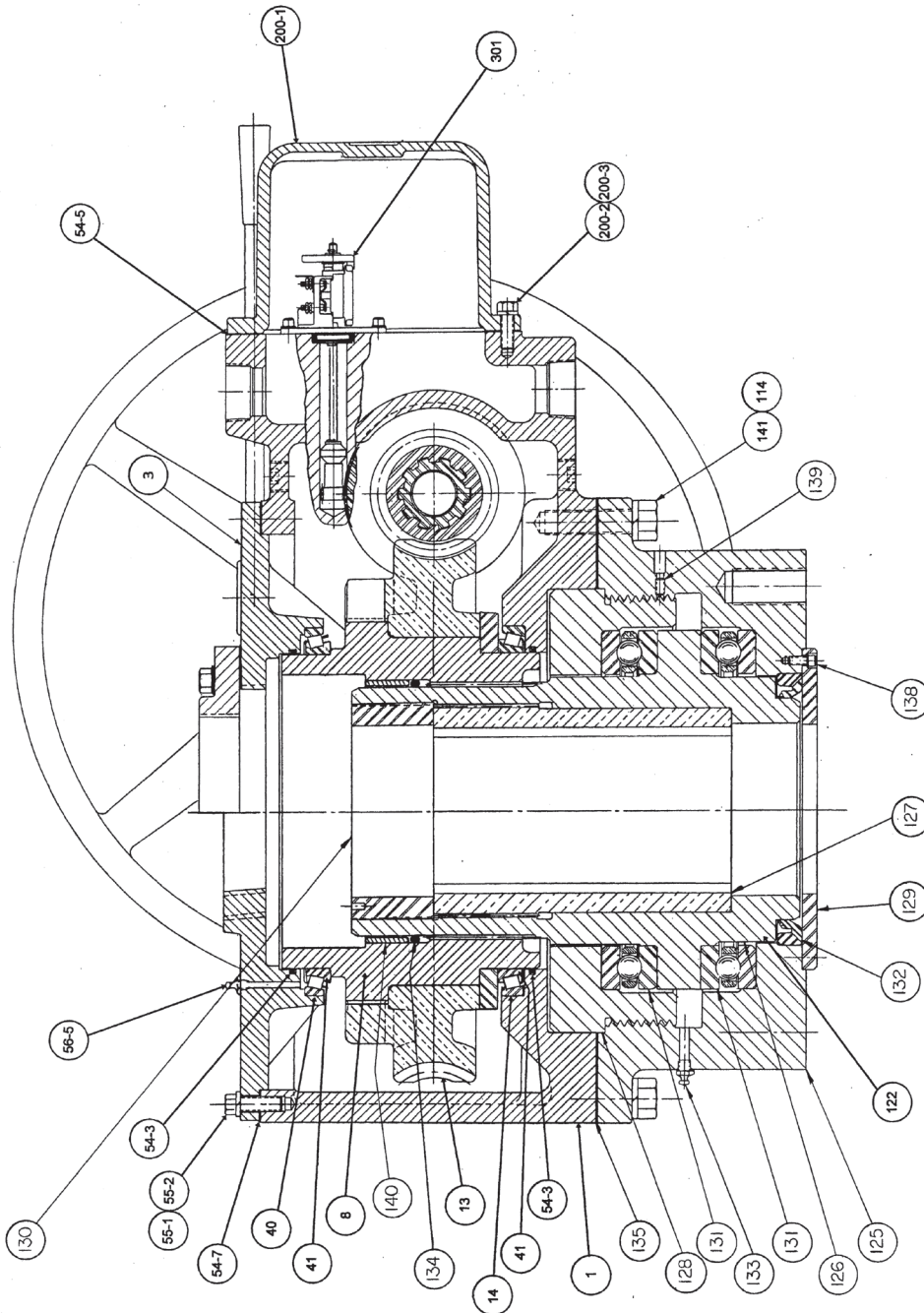

Drawing 01-608-0141-4_2of3

Figure 7.9 – L120-2000 Side View (Refer to Table 8.2 for parts list)

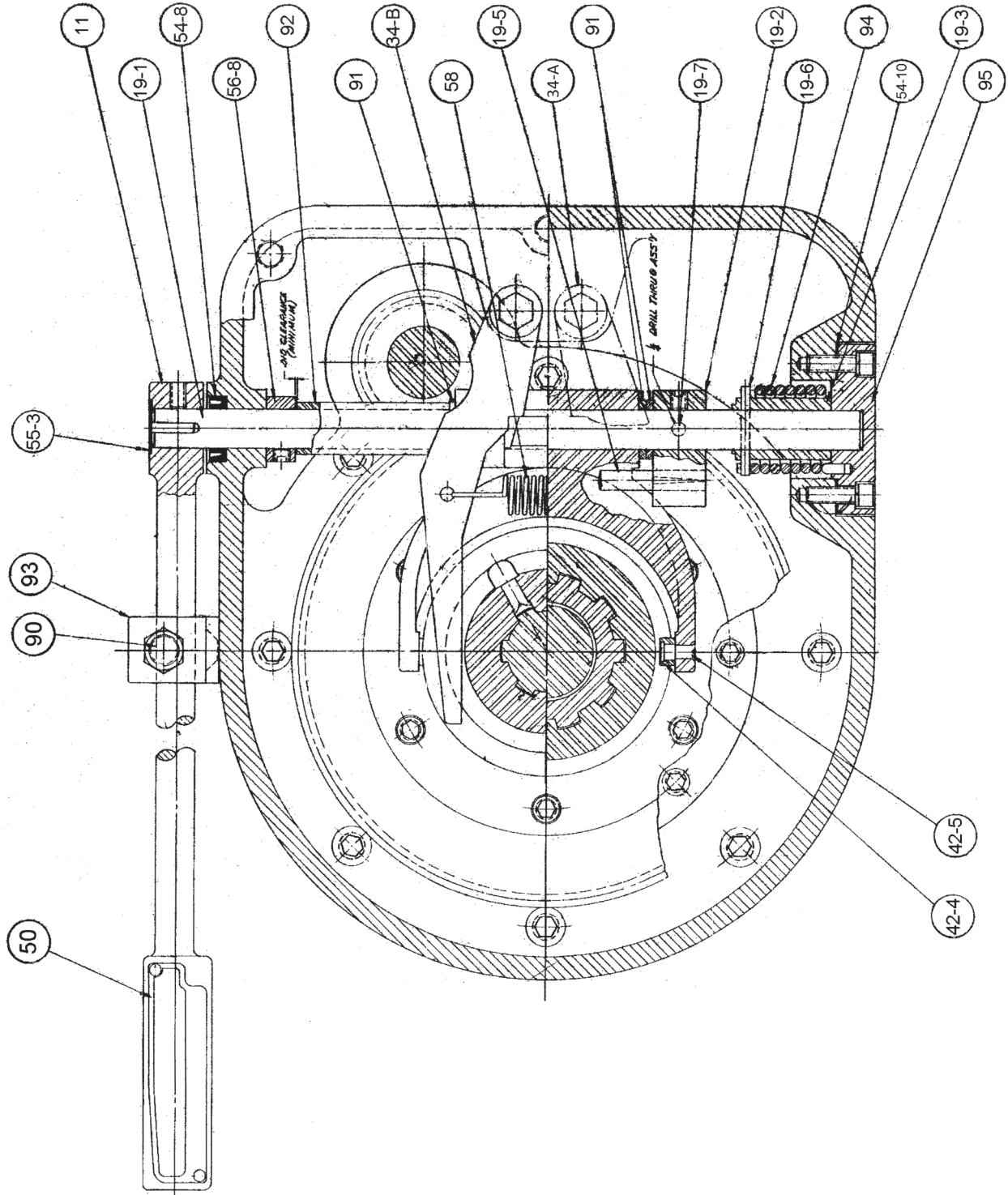

Figure 7.10 - L120-2000 Exploded View

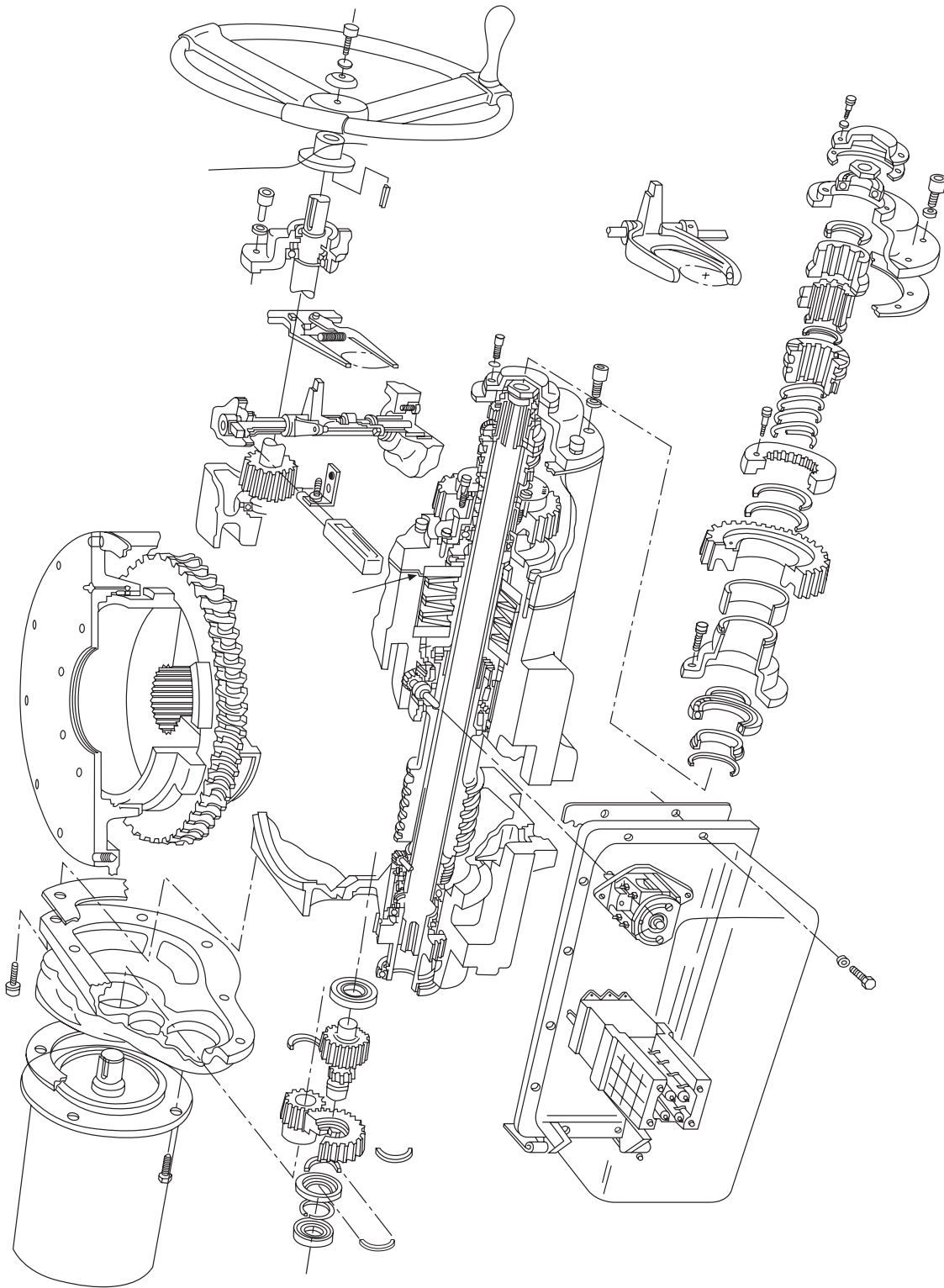

Table 7.2 - L120-2000 typical parts list

Piece No.	Quantity	Description
1	1	Housing
2	1	Declutch Housing
3	1	Housing Cover
4	1	Worm Shaft End Cap
5	1	Handwheel
8	1	Drive Sleeve
9	1	Handwheel Gear
11	1	Declutch Lever
13	1	Worm Gear
14	1	Bearing Cup
16-1	1	Bearing Cartridge Cap
16-2	2	Thrust Washer
16-3	various	Belleville Spring
16-5	1	Torque Limit Sleeve
16-8	1	Bearing Cartridge Stem
16-10	1	Cartridge Stem Locking Nut
17	1	Hollow Drive Shaft
18	1	Handwheel Shaft and Pinion
19-1	1	Declutch Shaft
19-2	1	Declutch Arm
19-3	1	Declutch Shaft Drum
19-5	1	Groove Pin
19-6	1	Roll Pin
19-7	1	Roll Pin
22	1	Motor Adapter
30-1	1	Worm
30-2	1	Worm Bushing
31-1	1	Motor Pinion
31-2	1	Intermediate Gear
32-1	1	Intermediate Pinion
32-2	1	Output Worm Shaft Gear
33	1	Sliding Gear Clutch
34-A	1	Clutch Tripper
34-B	1	Clutch Tripper
36	1	Worm Gear Spacer
37	1	Shim Set Bearing
40	1	Bearing Cup
41	1	Bearing Cone
42-1	1	Declutch Fork
42-4	1	Fork Roller
42-5	1	Roller Pinion
44-1	1	Bearing Locknut
46	1	Clutch Compression Spring
49	1	Spring Washer

Piece No.	Quantity	Description
50	1	Declutch Lever Nameplate
52-1	1	Ball Bearing
52-6	1	Handwheel Shaft Bearing
52-7	1	Ball Bearing
52-8	1	Ball Bearing
52-9	1	Ball Bearing
53-3	1	Spirolox Ring
53-8	1	Spirolox Ring
53-9	1	Retaining Ring
54-1	1	Declutch Housing Gasket
54-2	2	Worm Shaft End Cap Gasket
54-3	1	Quad Ring
54-5	1	O-Ring
54-6	1	Oil Seal
54-7	3	Housing Cover Gasket
54-8	1	Oil Seal
54-10	1	Declutch Cap Gasket
54-11	1	Declutch Cover Gasket
55-1	1	Hex Head Cap Screw
55-2	1	Lockwasher
55-3	1	Welsh Plug
55-4	1	Soc Head Set Screw
55-5	1	Lockwasher
55-6	1	Soc Head Set Screw
55-7	1	Lockwasher
55-8	1	Soc Head Set Screw
55-9	1	Lockwasher
55-10	1	Jam Nut
55-11	1	Flat Head Mach Screw
55-12	1	Soc Head Set Screw
55-14	1	Lockwasher
55-15	1	Drive Screw
56-5	1	Grease Fitting
56-7	1	Key
56-8	1	Hallowel Collar
56-9	1	Soc Head Set Screw
56-10	1	Lockwasher
56-12	1	Soc Head Set Screw
56-13	2	Tripper Bolt
56-15	1	Key
56-16	1	Key
56-17	1	Soc Head Set Screw
56-20	1	Soc Head Set Screw
56-21	1	Soc Head Set Screw

Table 7.2 Continued - L120-2000 typical parts list

Piece No.	Quantity	Description
58	1	Tripper Spring
70	1	Hinge
70-1	1	Hex Head Cap Screw
70-2	1	Lockwasher
73	2	Bearing Cup
76	1	Gear Limit Threaded Collar
77	1	Solid Drive Shaft
78	1	Gear Clutch Spacer
79	1	Bearing Adapter
80-1	1	Bearing Locknut
81-1	1	Bearing Locknut
81-2	1	Bearing Locknut
82-1	1	Flexible Jaw Clutch Housing
82-2	1	Motor Clutch Gear Cam Pin
82-3	1	Flexible Jaw Clutch Sleeve
82-4	1	Nylon Insert
82-5	1	Nylon Insert
82-6	6	Clutch Sleeve Insert
82-7	1	Flexible Jaw Clutch Collar
83	1	Handwheel Clutch
84	1	Gear Mounting Bracket
85	1	Handwheel Gear Bushing
86	1	Declutch Housing Cover
87	1	Splined Insert
88	1	Handwheel Washer
89	1	Handwheel Gear Spacer
90	1	Stop Stud
91	3	Declutch Shaft Washer
92	1	Declutch Shaft Spacer
93	1	Declutch Lever Stop
94	1	Torsion Spring
95	1	Declutch Cap
101	1	Bearing Spacer

Piece No.	Quantity	Description
102	1	Gear Insert
103	1	Split Ring
104	1	Retaining Ring
105	1	Motor Adaptor Gasket
106	1	Hex Head Cap Screw
107	1	Lockwasher
114	1	Hex Head Cap Screw
122	1	Thrust Drive Sleeve
125	1	Thrust Adapter Housing
126	1	Thrust Drive Sleeve
127	1	Stem Nut
128	1	Bearing Cartridge
129	1	Seal Retainer Plate
130	1	Drive Sleeve Locknut
131	1	Bearing Roller Assembly
132	1	Oil Seal
133	1	Grease Fitting
134	1	O-Ring
135	1	Housing Thrust Adapter Gasket
136	1	Hex Head Cap Screw
137	1	Lockwasher
138	1	Soc Head Set Screw
139	1	Soc Head Set Screw
140	1	Seal Retainer Sleeve
141	1	Lockwasher
162	1	Motor Adaptor Gasket
182	1	Handwheel Spinner Kit
200-1	1	Limit Switch Compartment Cover
200-2	1	Hex Head Cap Screw
200-3	1	Lockwasher
301	1	Torque Switch
305	1	Geared Limit Switch

8

Standard Wiring Diagrams

Figure 8.1 – Wiring Diagram – No Controls

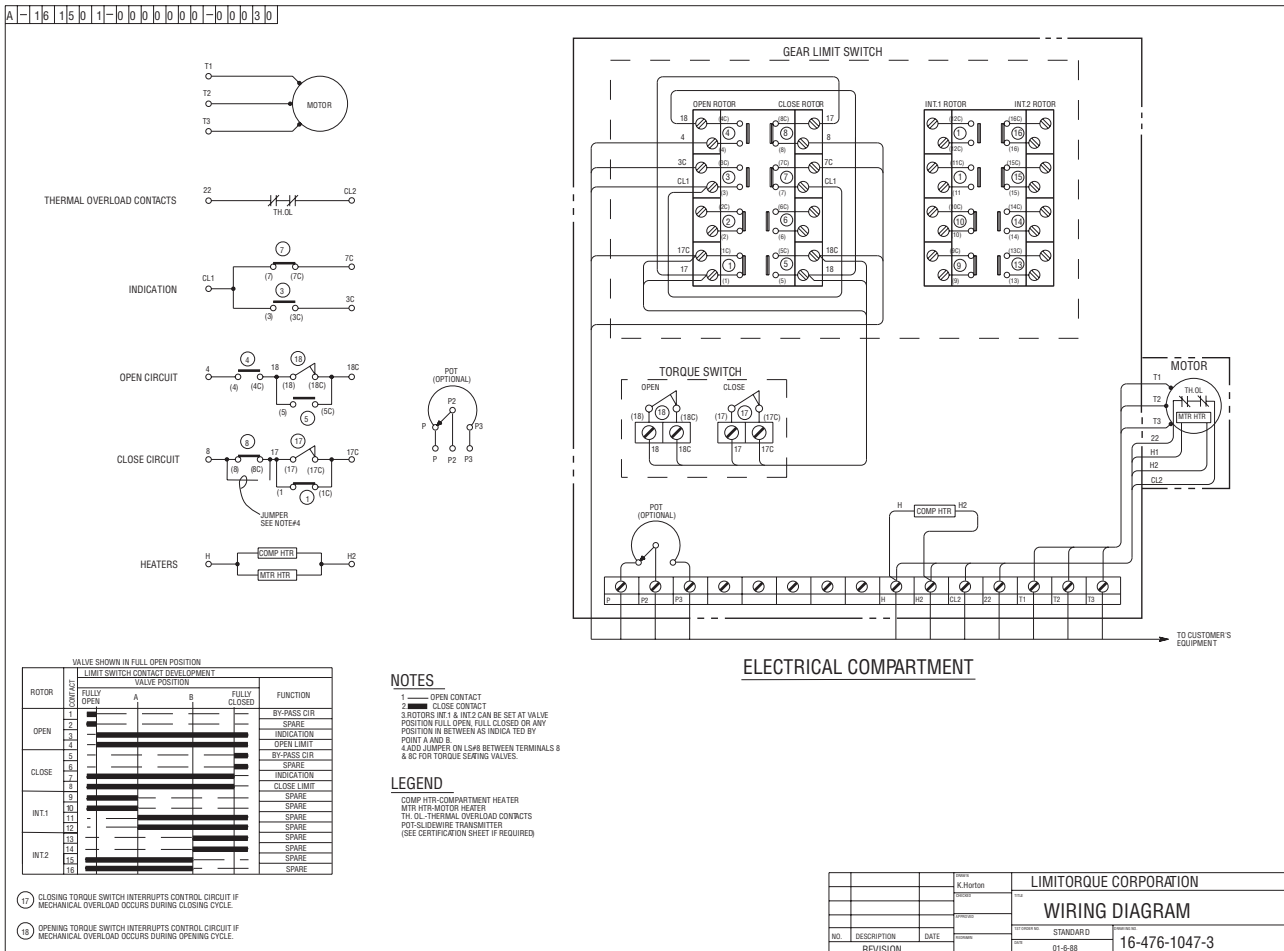
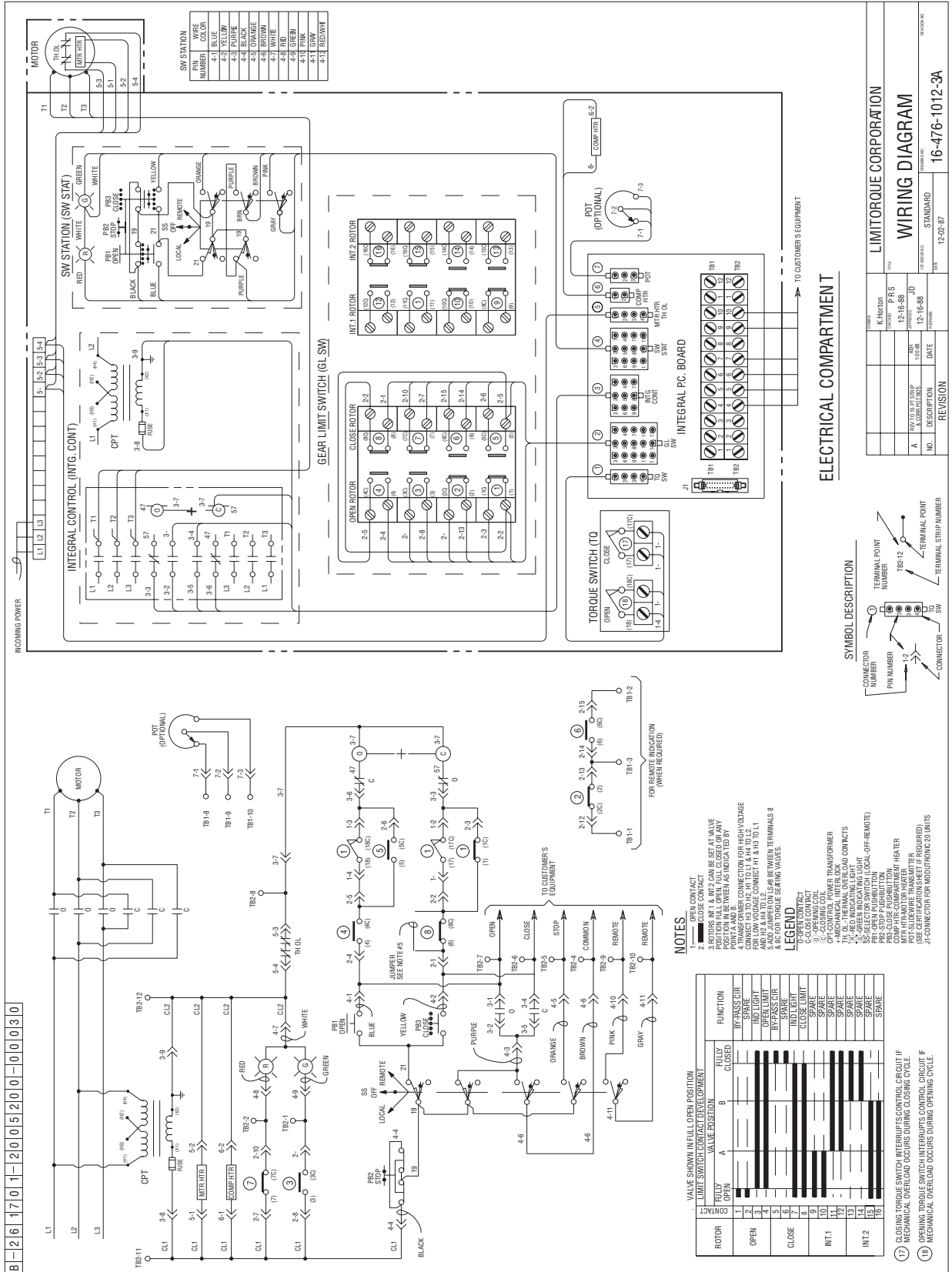

Figure 8.2 – Wiring Diagram – Integral Controls



REV	12-02-87
DATE	12-02-87
DESCRIPTION	REVISION
NO.	16-476-1012-3A
DATE	12-16-88
DESCRIPTION	WIRING DIAGRAM
NO.	12-16-88
DATE	12-16-88
DESCRIPTION	WIRING DIAGRAM
NO.	12-16-88
DATE	12-16-88
DESCRIPTION	WIRING DIAGRAM

REV	12-02-87
DATE	12-02-87
DESCRIPTION	REVISION
NO.	16-476-1012-3A
DATE	12-16-88
DESCRIPTION	WIRING DIAGRAM
NO.	12-16-88
DATE	12-16-88
DESCRIPTION	WIRING DIAGRAM
NO.	12-16-88
DATE	12-16-88
DESCRIPTION	WIRING DIAGRAM

REV	12-02-87
DATE	12-02-87
DESCRIPTION	REVISION
NO.	16-476-1012-3A
DATE	12-16-88
DESCRIPTION	WIRING DIAGRAM
NO.	12-16-88
DATE	12-16-88
DESCRIPTION	WIRING DIAGRAM
NO.	12-16-88
DATE	12-16-88
DESCRIPTION	WIRING DIAGRAM

REV	12-02-87
DATE	12-02-87
DESCRIPTION	REVISION
NO.	16-476-1012-3A
DATE	12-16-88
DESCRIPTION	WIRING DIAGRAM
NO.	12-16-88
DATE	12-16-88
DESCRIPTION	WIRING DIAGRAM
NO.	12-16-88
DATE	12-16-88
DESCRIPTION	WIRING DIAGRAM

17 CLOSING TORQUE SWITCH INTERRUPTS CONTROL CIRCUIT IF MECHANICAL OVERLOAD OCCURS DURING CLOSING CYCLE.
 18 OPENING TORQUE SWITCH INTERRUPTS CONTROL CIRCUIT IF MECHANICAL OVERLOAD OCCURS DURING OPENING CYCLE.

Figure 8.3 – Wiring Diagram – NCU

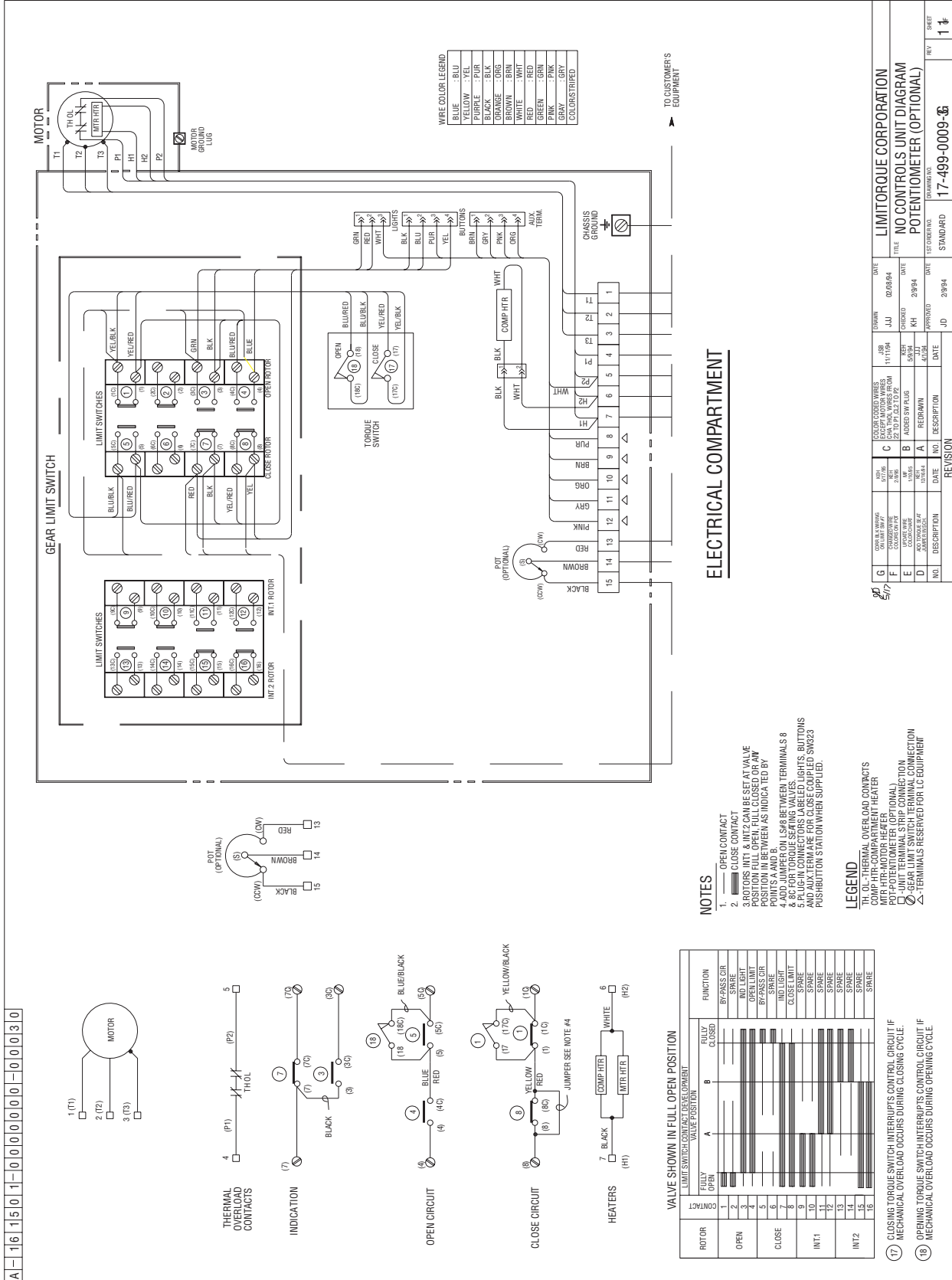

A - 16 15 0 1 - 0 0 0 0 0 0 0 0 - 0 0 0 3 0

9 Troubleshooting

Problem	Check
Geared limit switch fails to stop valve travel.	<ul style="list-style-type: none"> A. Control wiring and motor reversing contactor. B. Geared limit switch setting. C. Setting rod to see that it has been backed off after each side of the switch has been set. D. Remove limit switch and inspect for damaged or broken gear teeth.
Unable to operate actuator by motor.	<ul style="list-style-type: none"> A. Motor power and control circuits for supply and continuity. B. Supply voltage vs. motor and controller nameplate rating. If O.K., then check motor amperage load. C. For stalled motor. Shut off power and operate actuator by handwheel to move the valve.
Excessive handwheel effort.	<ul style="list-style-type: none"> A. Lubrication method and valve stem for damage. B. If the valve packing gland is too tight. C. If the valve is improperly lubricated. D. If the stem nut is too tight on valve stem. E. For faulty or damaged valve or parts.

10

How to Order Parts

To order parts or obtain further information about your Limitorque L120 valve actuators, contact your local Flowserve Limitorque distributor, sales office, or:

Flowserve Limitorque
5114 Woodall Road
P.O. Box 11318
Lynchburg, VA 24506-1318

Phone (434) 528-4400
Fax (434) 845-9736

To find the nearest Limitorque distributor or sales office near you, go to www.limitorque.com

All inquiries or orders must be accompanied by the following information:

1. Actuator Size
2. Order Number
3. Serial Number

This information can be found on the Limitorque nameplate affixed to the actuator.

11

EC Declaration of Conformity

Application of Council Directive(s)

2004/108/EC; EMC Directive
2006/42/EC; Machinery Directive
2003/10/EC; Airborne Noise Directive

Standard(s) to which Conformity is Declared

Machinery
EN 60204-1:2006+A1:2009

EMC – Emissions
EN 61000-6-3:2007+A1:2011
EN 61000-6-4:2007+A1:2011
EN 55011:2007

Immunity
EN 61000-6-2:2005
EN 61000-6-1:2007

Airborne Noise
EN 60204-1:2006+A1:2009

Materials of Construction

Control Cover - Aluminum Alloy 319 – WP; Cast Iron ASTM A48, Class 35 - XP
CS Station - Aluminum Alloy 319
Nameplate - Stainless Steel
Housing - Cast iron, ASTM A48, Class 35; or Ductile Iron, ASTM A536

Manufacturer's Name

Flowserve Limitorque

Manufacturer's Address

5114 Woodall Road Lynchburg, VA 24502

Importer's Name

Flowserve GB Ltd, Limitorque Division

Importer's Address

Euro House Abex Road Newbury Berkshire, RG14 5EY England

Type & Description of Equipment

Valve Actuators

Model Numbers

SMB-000, 00, 0, 1, 2, 3, 4, 5, L120-190, 420, 800, 2000

SMB Series Note: Tested with Limitorque products only and with standards applicable at time of tests.

I, the undersigned, hereby declare that the equipment specified above conforms to the above Directive(s) and Standard(s).



John Thilking PE
Senior Engineer, ATEX/IECEx Authorized Person, Flowserve Limitorque

Flowserve Limitorque
5114 Woodall Rd
Lynchburg VA 24502
August 28, 2012



This page intentionally left blank.



Flowserve Corporation

United States

Flowserve Limatorque
5114 Woodall Road
P.O. Box 11318
Lynchburg, VA 24506-1318
Phone: 434-528-4400
Fax: 434-845-9736

England

Flowserve Limatorque
Euro House
Abex Road
Newbury
Berkshire, RG14 5EY
United Kingdom
Phone: 44-1-635-46999
Fax: 44-1-635-36034

Singapore

Limatorque Asia, Pte., Ltd.
12, Tuas Avenue 20
Singapore 638824
Phone: 65-6868-4628
Fax: 65-6862-4940

China

Limatorque Beijing, Pte., Ltd.
RM A1/A2
22/F, East Area, Hanwei Plaza
No. 7 Guanghua Road, Chaoyang
District
Beijing 100004, Peoples Republic
of
China
Phone: 86-10-5921-0606
Fax: 86-10-6561-2702

India

Flowserve Limatorque
Plot No. #4, 1 A, Road No. 8,
EPIP
Whitefield, Bangalore – 560066
Karnataka
India
Phone: 91-80-40146200
Fax: 91-80-28410286

Italy

Flowserve Limatorque
Fluid Power Systems
Via Rio Vallone 17
20883 Mezzago MB
Italy
Phone: 39-039-620601
Fax: 39-039-62060 213

FCD LMENIM1203-01-A4 Printed in USA. May 2015

To find your local Flowserve representative
or for more information about Flowserve Corporation, visit
www.flowserve.com.

Flowserve Corporation has established industry leadership in the design and manufacture of its products. When properly selected, this Flowserve product is designed to perform its intended function safely during its useful life. However, the purchaser or user of Flowserve products should be aware that Flowserve products might be used in numerous applications under a wide variety of industrial service conditions. Although Flowserve can (and often does) provide general guidelines, it cannot provide specific data and warnings for all possible applications. The purchaser/user must therefore assume the ultimate responsibility for the proper sizing and selection, installation, operation, and maintenance of Flowserve products. The purchaser/user should read and understand the Installation Operation Maintenance (IOM) instructions included with the product, and train its employees and contractors in the safe use of Flowserve products in connection with the specific application.

While the information and specifications contained in this literature are believed to be accurate, they are supplied for informative purposes only and should not be considered certified or as a guarantee of satisfactory results by reliance thereon. Nothing contained herein is to be construed as a warranty or guarantee, express or implied, regarding any matter with respect to this product. Because Flowserve is continually improving and upgrading its product design, the specifications, dimensions and information contained herein are subject to change without notice. Should any question arise concerning these provisions, the purchaser/user should contact Flowserve Corporation at any one of its worldwide operations or offices.

© 2015 Flowserve Corporation, Irving, Texas, USA. Flowserve is a registered trademark of Flowserve Corporation.