



# USER INSTRUCTIONS

## **IDP® CPX, CPXR, CPXN and CPXP**

Single stage, end suction, centrifugal, chemical process pumps

PCN=71569117 03-17 (E) (Based on C937KH013, C937KH054, C961KH001 and C937KH067.) Original instructions.

**Installation**  
**Operation**  
**Maintenance**

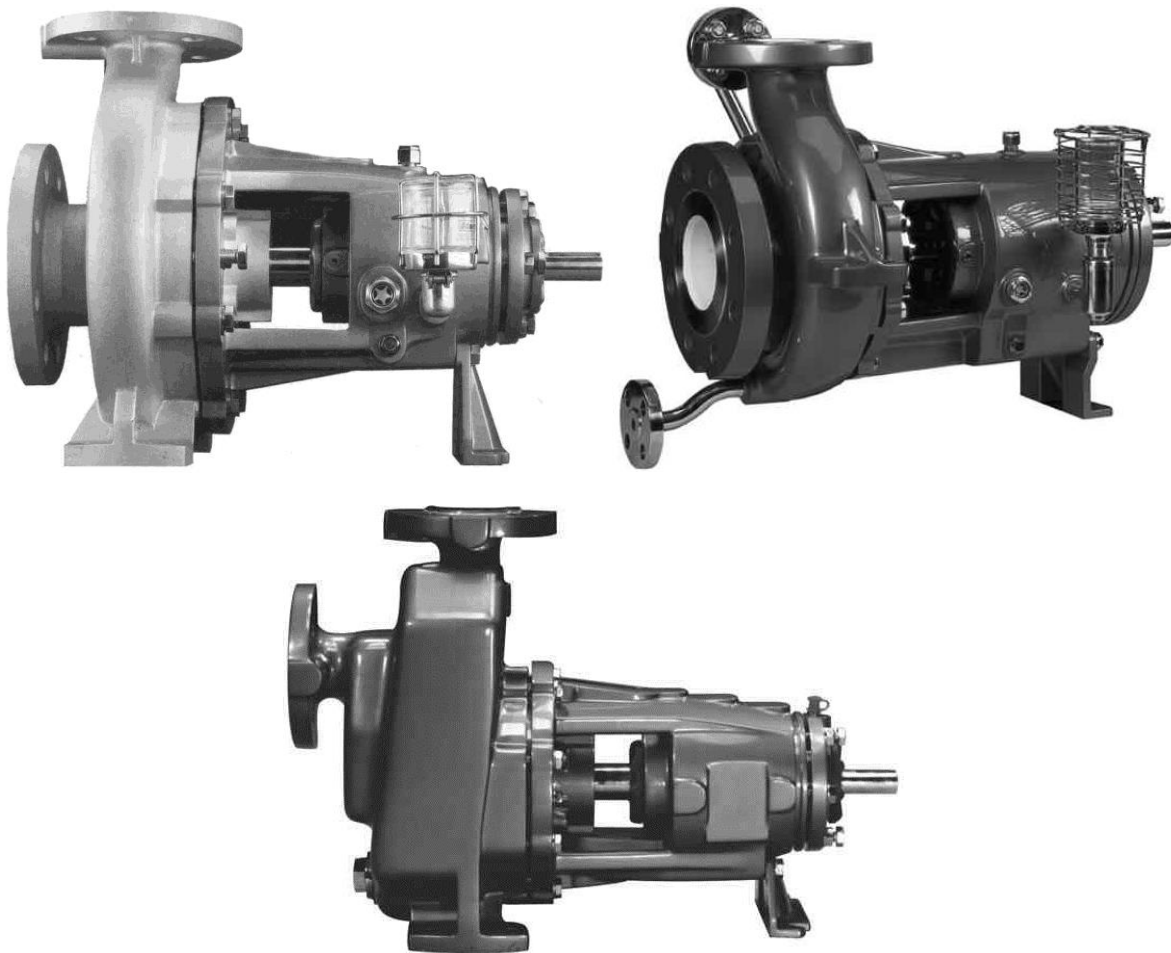

 ***These instructions must be read prior to installing, operating, using and maintaining this equipment.***

***Experience In Motion***

**CONTENTS**

	<b>Page</b>		<b>Page</b>
1 INTRODUCTION AND SAFETY .....	4	6.8 Disassembly .....	28
1.1 General .....	4	6.9 Examination of parts .....	29
1.2 CE marking and approvals .....	4	6.10 Assembly .....	30
1.3 Disclaimer .....	4	6.11 Sealing arrangements .....	32
1.4 Copyright .....	4	Q - Rp ¼ in. quench .....	33
1.5 Duty conditions .....	4	BI - Rp ¼ in. barrier liquid inlet .....	34
1.6 Safety .....	5	7 FAULTS; CAUSES AND REMEDIES .....	35
1.7 Nameplate and safety labels .....	9	8 PARTS LISTS AND DRAWINGS .....	37
1.8 Specific machine performance .....	9	8.1 CPX and CPXN .....	37
1.9 Noise level .....	10	8.2 CPXR .....	39
2 TRANSPORT AND STORAGE .....	11	8.3 CPXP .....	40
2.1 Consignment receipt and unpacking .....	11	8.4 CPX, CPXR, CPXN and CPXP additional details .....	42
2.2 Handling .....	11	8.5 Parts interchangeability .....	43
2.3 Lifting .....	11	8.6 General arrangement drawing .....	44
2.4 Storage .....	11	9 CERTIFICATION .....	45
2.5 Recycling and end of product life .....	12	10 OTHER RELEVANT DOCUMENTATION AND MANUALS .....	45
3 DESCRIPTION .....	12	10.1 Supplementary User Instruction manuals ..	45
3.1 Configurations .....	12	10.2 Change notes .....	45
3.2 Name nomenclature .....	12	10.3 Additional sources of information .....	45
3.3 Design of major parts .....	12		
3.4 Performance and operating limits .....	13		
4 INSTALLATION .....	13		
4.1 Location .....	13		
4.2 Part assemblies .....	13		
4.3 Foundation .....	13		
4.4 Grouting .....	13		
4.5 Initial alignment .....	13		
4.6 Piping .....	14		
4.7 Final shaft alignment check .....	18		
4.8 Electrical connections .....	18		
4.9 Protection systems .....	19		
5 COMMISSIONING, START-UP, OPERATION AND SHUTDOWN .....	19		
5.1 Pre-commissioning procedure .....	19		
5.2 Pump lubricants .....	20		
5.3 Open impeller clearance .....	21		
5.4 Direction of rotation .....	21		
5.5 Guarding .....	21		
5.6 Priming and auxiliary supplies .....	22		
5.7 Starting the pump .....	22		
5.8 Running the pump .....	23		
5.9 Stopping and shutdown .....	24		
5.10 Hydraulic, mechanical and electrical duty ..	24		
6 MAINTENANCE .....	25		
6.1 General .....	25		
6.2 Maintenance schedule .....	25		
6.3 Spare parts .....	26		
6.4 Recommended spares .....	26		
6.5 Tools required .....	27		
6.6 Fastener torques .....	27		
6.7 Setting impeller clearance .....	27		

**INDEX**

	Page		Page
Additional sources (10.3).....	42	Reassembly (6.10, Assembly) .....	27
Alignment of shafting (see 4.3, 4.5 and 4.7)		Receipt and unpacking (2.1) .....	11
Assembly (6.10).....	27	Recommended fill quantities (see 5.2.2).....	18
ATEX marking (1.6.4.2) .....	7	Recommended grease lubricants (5.2.3).....	18
Bearing sizes and capacities (5.2.2).....	18	Recommended oil lubricants (5.2.1) .....	18
CE marking and approvals (1.2).....	4	Recommended spares (6.4).....	24
Certification (9) .....	42	Recycling (2.5) .....	11
Change notes (10.2) .....	42	Replacement parts (6.3 and 6.4).....	23/24
Clearances, impeller (6.7) .....	24	Running the pump (5.8) .....	20
Commissioning and operation (5).....	17	Safety action (1.6.3) .....	5
Compliance, ATEX (1.6.4.1).....	7	Safety labels (1.7.2) .....	9
Configurations (3.1) .....	12	Safety markings (1.6.1) .....	5
Copyright (1.4) .....	4	Safety, protection systems (see 1.6 and 4.9)	
Design of major parts (3.3) .....	12	Sealing arrangements (6.11).....	29
Direction of rotation (5.4) .....	19	Sectional drawings (8).....	34
Disassembly (6.8) .....	25	Setting impeller clearance (6.7) .....	24
Disclaimer (1.3).....	4	Sound pressure level (1.9, Noise level) .....	9
Dismantling (6.8, Disassembly) .....	25	Sources, additional information (10.3) .....	42
Drawings (8) .....	34	Spare parts (6.3) .....	23
Duty conditions (1.5).....	4	Specific machine performance (1.8) .....	9
Electrical connections (4.8) .....	17	Starting the pump (5.7).....	20
End of product life (2.5) .....	11	Stop/start frequency (5.8.5).....	21
Examination of parts (6.9) .....	26	Stopping and shutdown (5.9) .....	21
Fastener torques (6.6) .....	24	Storage, pump (2.4) .....	11
Faults; causes and remedies (7) .....	32	Storage, spare parts (6.3.2) .....	24
Foundation (4.3) .....	13	Supplementary manuals or information sources.....	42
General arrangement drawing (8.6) .....	41	Supplementary User Instructions (10.1).....	42
General assembly drawings (8).....	34	Thermal expansion (4.5.1) .....	13
Grouting (4.4).....	13	Tools required (6.5) .....	24
Guarding (5.5).....	19	Torques for fasteners (6.6).....	24
Handling (2.2) .....	11	Trouble-shooting (see 7) .....	32
Hydraulic, mechanical and electrical duty (5.10).....	21	Vibration (5.8.4).....	21
Impeller clearance (see 5.3 and 6.7)			
Inspection (6.2.1 and 6.2.2).....	23		
Installation (4) .....	13		
Lifting (2.3).....	11		
Location (4.1).....	13		
Lubrication (see 5.1.1, 5.2 and 6.2.3)			
Lubrication schedule (5.2.5) .....	18		
Maintenance (6).....	22		
Maintenance schedule (6.2) .....	23		
Name nomenclature (3.2).....	12		
Nameplate (1.7.1) .....	9		
Operating limits (3.4.1) .....	12		
Ordering spare parts (6.3.1) .....	23		
Part assemblies (4.2).....	13		
Parts interchangeability (8.5).....	40		
Parts lists (8).....	34		
Performance (3.4).....	12		
Piping (4.6) .....	14		
Pre-commissioning (5.1).....	17		
Priming and auxiliary supplies (5.6).....	19		
Protection systems (4.9).....	17		

## 1 INTRODUCTION AND SAFETY

### 1.1 General



***These instructions must always be kept close to the product's operating location or directly with the product.***

Flowserve products are designed, developed and manufactured with state-of-the-art technologies in modern facilities. The unit is produced with great care and commitment to continuous quality control, utilising sophisticated quality techniques and safety requirements.

Flowserve is committed to continuous quality improvement and being at service for any further information about the product in its installation and operation or about its support products, repair and diagnostic services.

These instructions are intended to facilitate familiarization with the product and its permitted use. Operating the product in compliance with these instructions is important to help ensure reliability in service and avoid risks. The instructions may not take into account local regulations; ensure such regulations are observed by all, including those installing the product. Always coordinate repair activity with operations personnel, and follow all plant safety requirements and applicable safety and health laws and regulations.



***These instructions must be read prior to installing, operating, using and maintaining the equipment in any region worldwide. The equipment must not be put into service until all the conditions relating to safety, noted in the instructions, have been met. Failure to follow and apply the present user instructions is considered to be misuse. Personal injury, product damage, delay or failure caused by misuse are not covered by the Flowserve warranty.***

### 1.2 CE marking and approvals

It is a legal requirement that machinery and equipment put into service within certain regions of the world shall conform with the applicable CE Marking Directives covering Machinery and, where applicable, Low Voltage Equipment, Electromagnetic Compatibility (EMC), Pressure Equipment Directive (PED) and Equipment for Potentially Explosive Atmospheres (ATEX).

Where applicable, the Directives and any additional Approvals, cover important safety aspects relating to machinery and equipment and the satisfactory provision of technical documents and safety instructions. Where applicable this document incorporates information relevant to these Directives and Approvals.

To confirm the Approvals applying and if the product is CE marked, check the serial number plate markings and the Certification. (See section 9, *Certification*.)

### 1.3 Disclaimer

***Information in these User Instructions is believed to be complete and reliable. However, in spite of all of the efforts of Flowserve Corporation to provide comprehensive instructions, good engineering and safety practice should always be used.***

Flowserve manufactures products to exacting International Quality Management System Standards as certified and audited by external Quality Assurance organisations. Genuine parts and accessories have been designed, tested and incorporated into the products to help ensure their continued product quality and performance in use. As Flowserve cannot test parts and accessories sourced from other vendors the incorrect incorporation of such parts and accessories may adversely affect the performance and safety features of the products. The failure to properly select, install or use authorised Flowserve parts and accessories is considered to be misuse. Damage or failure caused by misuse is not covered by the Flowserve warranty. In addition, any modification of Flowserve products or removal of original components may impair the safety of these products in their use.

### 1.4 Copyright

All rights reserved. No part of these instructions may be reproduced, stored in a retrieval system or transmitted in any form or by any means without prior permission of Flowserve Solution group.

### 1.5 Duty conditions

This product has been selected to meet the specifications of your purchaser order. The acknowledgement of these conditions has been sent separately to the Purchaser. A copy should be kept with these instructions.



***The product must not be operated beyond the parameters specified for the application. If there is any doubt as to the suitability of the product for the application intended, contact Flowserve for advice, quoting the serial number.***

If the conditions of service on your purchase order are going to be changed (for example liquid pumped, temperature or duty) it is requested that the user seeks the written agreement of Flowserve before start up.

## 1.6 Safety

### 1.6.1 Summary of safety markings

These User Instructions contain specific safety markings where non-observance of an instruction would cause hazards. The specific safety markings are:

 **DANGER** This symbol indicates electrical safety instructions where non-compliance will involve a high risk to personal safety or the loss of life.

 This symbol indicates safety instructions where non-compliance would affect personal safety and could result in loss of life.

 This symbol indicates “hazardous and toxic fluid” safety instructions where non-compliance would affect personal safety and could result in loss of life.

 **CAUTION** This symbol indicates safety instructions where non-compliance will involve some risk to safe operation and personal safety and would damage the equipment or property.

 This symbol indicates explosive atmosphere zone marking according to ATEX. It is used in safety instructions where non-compliance in the hazardous area would cause the risk of an explosion.

 This symbol is used in safety instructions to remind not to rub non-metallic surfaces with a dry cloth; ensure the cloth is damp. It is used in safety instructions where non-compliance in the hazardous area would cause the risk of an explosion.

**Note:** This sign is not a safety symbol but indicates an important instruction in the assembly process.

### 1.6.2 Personnel qualification and training

All personnel involved in the operation, installation, inspection and maintenance of the unit must be qualified to carry out the work involved. If the personnel in question do not already possess the necessary knowledge and skill, appropriate training and instruction must be provided. If required the operator may commission the manufacturer/supplier to provide applicable training.

Always coordinate repair activity with operations and health and safety personnel, and follow all plant safety requirements and applicable safety and health laws and regulations.

### 1.6.3 Safety action

***This is a summary of conditions and actions to help prevent injury to personnel and damage to the environment and to equipment. For products used in potentially explosive atmospheres section 1.6.4 also applies.***

 **DANGER** NEVER DO MAINTENANCE WORK WHEN THE UNIT IS CONNECTED TO POWER

 **GUARDS MUST NOT BE REMOVED WHILE THE PUMP IS OPERATIONAL**

 **DRAIN THE PUMP AND ISOLATE PIPEWORK BEFORE DISMANTLING THE PUMP**

The appropriate safety precautions should be taken where the pumped liquids are hazardous.

 **FLUORO-ELASTOMERS** (When fitted.) When a pump has experienced temperatures over 250 °C (482 °F), partial decomposition of fluoro-elastomers (example: Viton) will occur. In this condition these are extremely dangerous and skin contact must be avoided.

 **HANDLING COMPONENTS** Many precision parts have sharp corners and the wearing of appropriate safety gloves and equipment is required when handling these components. To lift heavy pieces above 25 kg (55 lb) use a crane appropriate for the mass and in accordance with current local regulations.

 **THERMAL SHOCK** Rapid changes in the temperature of the liquid within the pump can cause thermal shock, which can result in damage or breakage of components and should be avoided.

 **NEVER APPLY HEAT TO REMOVE IMPELLER** Trapped lubricant or vapour could cause an explosion.

 **HOT (and cold) PARTS** If hot or freezing components or auxiliary heating supplies can present a danger to operators and persons entering the immediate area action must be taken to avoid accidental contact. If complete protection is not possible, the machine access must be limited to maintenance staff only, with clear visual warnings and indicators to those entering the immediate area. Note: bearing housings must not be insulated and drive motors and bearings may be hot.



**If the temperature is greater than 80 °C (175 °F) or below -5 °C (23 °F) in a restricted zone, or exceeds local regulations, action as above shall be taken.**



**HAZARDOUS LIQUIDS**

When the pump is handling hazardous liquids care must be taken to avoid exposure to the liquid by appropriate siting of the pump, limiting personnel access and by operator training. If the liquid is flammable and/or explosive, strict safety procedures must be applied.

**Gland packing must not be used when pumping hazardous liquids.**



**PREVENT EXCESSIVE EXTERNAL PIPE LOAD**

Do not use pump as a support for piping. Do not mount expansion joints, unless allowed by Flowserve in writing, so that their force, due to internal pressure, acts on the pump flange.



**NEVER RUN THE PUMP DRY**



**ENSURE CORRECT LUBRICATION**  
(See section 5, *Commissioning, startup, operation and shutdown.*)



**ONLY CHECK DIRECTION OF MOTOR ROTATION WITH COUPLING ELEMENT/ PINS REMOVED**

Starting in reverse direction of rotation will damage the pump.

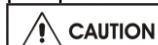

**START THE PUMP WITH OUTLET VALVE PART OPENED**

(Unless otherwise instructed at a specific point in the User Instructions.)

This is recommended to minimize the risk of overloading and damaging the pump or motor at full or zero flow. Pumps may be started with the valve further open only on installations where this situation cannot occur. The pump outlet control valve may need to be adjusted to comply with the duty following the run-up process. (See section 5, *Commissioning start-up, operation and shutdown.*)



**INLET VALVES TO BE FULLY OPEN WHEN PUMP IS RUNNING**

Running the pump at zero flow or below the recommended minimum flow continuously will cause damage to the pump and mechanical seal.



**DO NOT RUN THE PUMP AT ABNORMALLY HIGH OR LOW FLOW RATES**

Operating at a flow rate higher than normal or at a flow rate with no back pressure on the pump may overload the motor and cause cavitation. Low flow rates may cause a reduction in pump/bearing life, overheating of the pump, instability and cavitation/vibration.

**1.6.4 Products used in potentially explosive atmospheres**



Measures are required to:

- Avoid excess temperature
- Prevent build up of explosive mixtures
- Prevent the generation of sparks
- Prevent leakages
- Maintain the pump to avoid hazard

The following instructions for pumps and pump units when installed in potentially explosive atmospheres must be followed to help ensure explosion protection. For ATEX, both electrical and non-electrical equipment must meet the requirements of European Directive 2014/34/EU. Always observe the regional legal Ex requirements eg Ex electrical items outside the EU may be required certified to other than ATEX eg IECEx, UL.

**1.6.4.1 Scope of compliance**



Use equipment only in the zone for which it is appropriate. Always check that the driver, drive coupling assembly, seal and pump equipment are suitably rated and/or certified for the classification of the specific atmosphere in which they are to be installed.

Where Flowserve has supplied only the bare shaft pump, the Ex rating applies only to the pump. The party responsible for assembling the ATEX pump set shall select the coupling, driver and any additional equipment, with the necessary CE Certificate/ Declaration of Conformity establishing it is suitable for the area in which it is to be installed.

The output from a variable frequency drive (VFD) can cause additional heating effects in the motor and so, for pumps sets with a VFD, the ATEX Certification for the motor must state that it covers the situation where electrical supply is from the VFD. This particular requirement still applies even if the VFD is in a safe area.

**1.6.4.2 Marking**

An example of ATEX equipment marking is shown below. The actual classification of the pump will be engraved on the nameplate.

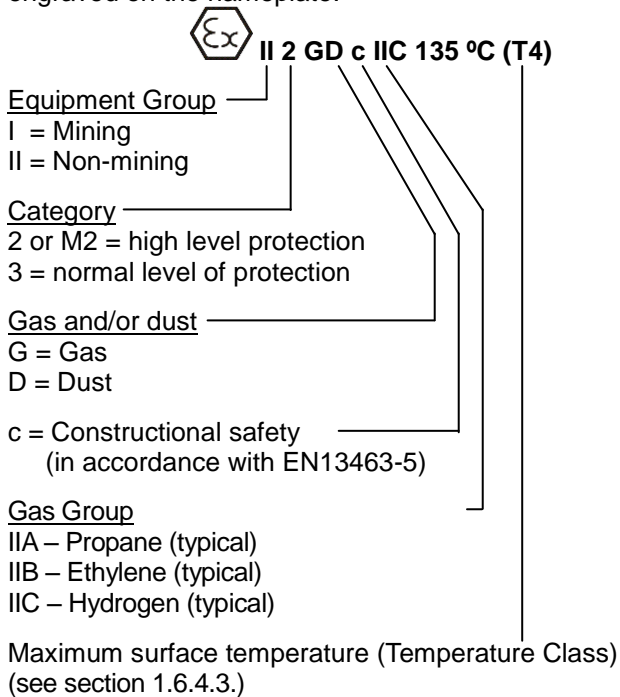

**1.6.4.3 Avoiding excessive surface temperatures**

ENSURE THE EQUIPMENT TEMPERATURE CLASS IS SUITABLE FOR THE HAZARD ZONE

Pumps have a temperature class as stated in the ATEX Ex rating on the nameplate. These are based on a maximum ambient of 40 °C (104 °F); refer to Flowserve for higher ambient temperatures.

The surface temperature on the pump is influenced by the temperature of the liquid handled. The maximum permissible liquid temperature depends on the ATEX temperature class and must not exceed the values in the table that follows.

**Maximum permitted liquid temperature for pumps**

Temperature class to EN13463-1	Maximum surface temperature permitted	Temperature limit of liquid handled
T6	85 °C (185 °F)	Consult Flowserve
T5	100 °C (212 °F)	Consult Flowserve
T4	135 °C (275 °F)	115 °C (239 °F) *
T3	200 °C (392 °F)	180 °C (356 °F) *
T2	300 °C (572 °F)	275 °C (527 °F) *
T1	450 °C (842 °F)	400 °C (752 °F) *

**Maximum permitted liquid temperature for pumps with self priming casing**

Temperature class to EN 13463-1	Maximum surface temperature permitted	Temperature limit of liquid handled
T6	85 °C (185 °F)	Consult Flowserve
T5	100 °C (212 °F)	Consult Flowserve
T4	135 °C (275 °F)	110 °C (230 °F) *
T3	200 °C (392 °F)	175 °C (347 °F) *
T2	300 °C (572 °F)	270 °C (518 °F) *
T1	450 °C (842 °F)	350 °C (662 °F) *

\*The table only takes the ATEX temperature class into consideration. Pump design or material, as well as component design or material, may further limit the maximum working temperature of the liquid.

The temperature rise at the seals and bearings and due to the minimum permitted flow rate is taken into account in the temperatures stated.

**The operator is responsible to ensure the specified maximum liquid temperature is not exceeded.**

Temperature classification “Tx” is used when the liquid temperature varies and when the pump is required to be used in differently classified potentially explosive atmospheres. In this case the user is responsible for ensuring that the pump surface temperature does not exceed that permitted in its actual installed location.

Avoid mechanical, hydraulic or electrical overload by using motor overload trips, temperature monitors or a power monitor and make routine vibration monitoring checks.

In dirty or dusty environments, make regular checks and remove dirt from areas around close clearances, bearing housings and motors.

Where there is any risk of the pump being run against a closed valve generating high liquid and casing external surface temperatures fit an external surface temperature protection device.

**Pumps with threaded on impellers only**

Do not attempt to check the direction of rotation with the coupling element/pins fitted due to the risk of severe contact between rotating and stationary components.

**Pumps with key drive impellers only**

If an explosive atmosphere exists during the installation, do not attempt to check the direction of rotation by starting the pump unfilled. Even a short run time may give a high temperature resulting from contact between rotating and stationary components.

**Additional requirements for CPXP pumps only**

Where the system operation does not ensure control of priming, as defined in these User Instructions, and the maximum permitted surface temperature of the T Class could be exceeded, fit an external surface temperature protection device.

**1.6.4.4 Preventing the build up of explosive mixtures**



ENSURE THE PUMP IS PROPERLY FILLED AND VENTED AND DOES NOT RUN DRY

Ensure the pump and relevant suction and discharge pipeline system is totally filled with liquid at all times during the pump operation, so that an explosive atmosphere is prevented.

In addition it is essential to make sure that seal chambers, auxiliary shaft seal systems and any heating and cooling systems are properly filled.

If the operation of the system cannot avoid this condition, fit an appropriate dry run protection device (for example liquid detection or a power monitor).

To avoid potential hazards from fugitive emissions of vapour or gas to atmosphere the surrounding area must be well ventilated.

**1.6.4.5 Preventing sparks**



To prevent a potential hazard from mechanical contact, the coupling guard must be non-sparking.

To avoid the potential hazard from random induced current generating a spark, the baseplate must be properly grounded.



Avoid electrostatic charge: do not rub non-metallic surfaces with a dry cloth; ensure cloth is damp.

For ATEX the coupling must be selected to comply with 2014/34/EU. Correct coupling alignment must be maintained.

**Additional requirement for metallic pumps on non-metallic baseplates**

When metallic components are fitted on a non-metallic baseplate they must be individually earthed.

**1.6.4.6 Preventing leakage**



The pump must only be used to handle liquids for which it has been approved to have the correct corrosion resistance.

Avoid entrapment of liquid in the pump and associated piping due to closing of suction and discharge valves, which could cause dangerous excessive pressures to occur if there is heat input to the liquid. This can occur if the pump is stationary or running.

Bursting of liquid containing parts due to freezing must be avoided by draining or protecting the pump and ancillary systems.

Where there is the potential hazard of a loss of a seal barrier fluid or external flush, the fluid must be monitored.

If leakage of liquid to atmosphere can result in a hazard, install a liquid detection device.

**1.6.4.7 Maintenance to avoid the hazard**



CORRECT MAINTENANCE IS REQUIRED TO AVOID POTENTIAL HAZARDS WHICH GIVE A RISK OF EXPLOSION

**The responsibility for compliance with maintenance instructions is with the plant operator.**

To avoid potential explosion hazards during maintenance, the tools, cleaning and painting materials used must not give rise to sparking or adversely affect the ambient conditions. Where there is a risk from such tools or materials, maintenance must be conducted in a safe area.

It is recommended that a maintenance plan and schedule is adopted. (See section 6, *Maintenance*.)



## 1.7 Nameplate and safety labels

### 1.7.1 Nameplate

For details of nameplate, see the *Declaration of Conformity*, or separate documentation included with these User Instructions.

### 1.7.2 Safety labels

		<b>WARNING</b>	<small>J218JZ250</small>
<small>ESSENTIAL PROCEDURES BEFORE STARTING:</small>			
<p>INSTALL AND OPERATE EQUIPMENT IN ACCORDANCE WITH THE INSTRUCTION MANUAL SUPPLIED SEPARATELY.</p> <p>ENSURE GUARDS ARE SECURELY IN PLACE.</p> <p>ENSURE CORRECT DIRECTION OF ROTATION.</p>	<p>ENSURE ALL EXTERNAL CONNECTIONS TO THE PUMP / SHAFT SEALING AND DRIVER ARE CONNECTED AND OPERATIONAL.</p> <p>FULLY PRIME UNIT AND SYSTEM. DO NOT RUN UNIT DRY.</p>	<p>FAILURE TO FOLLOW THESE PROCEDURES MAY RESULT IN PERSONAL INJURY AND / OR EQUIPMENT DAMAGE </p>	

<small>J218JZ265</small>	
<p>ENSURE CORRECT DRIVER DIRECTION OF ROTATION WITH COUPLING ELEMENT / PINS REMOVED: OTHERWISE SERIOUS DAMAGE MAY RESULT.</p> <p>VERIFIER LE SENS CORRECT DE ROTATION DU MOTEUR. POMPE DESACCOUPLEE / ENTRETOISE DEMONTEE. NE PAS SUIVRE CETTE RECOMMANDATION PEUT CONDUIRE A DE GRAVES DOMMAGES POUR LA POMPE</p>	<p>KONTROLLE VORGESCHRIEBENER DREHRICHTUNG ! HIERZU KUPPLUNGSZWISCHENSTÜCK / KUPPLUNGSBOLZEN ENTFERNEN. ANDERENFALLS ERNSTHAFTE SCHÄDEN !</p> <p>ZORG VOOR JUISTE ROTATIERICHTING VAN DRIJFAS WAARBIJ DE KOPPELEMENTEN / PENNEN VERWIJDERD ZIJN: VERZUM KAN ERNSTIGE SCHADE TOT GEVOLG HEBBEN.</p>

<small>J218/268</small>	
<p>ENSURE UNIT ON A FIRM FOUNDATION AND THAT COUPLING FACES ARE IN CORRECT ALIGNMENT PRIOR TO AND AFTER BOLTING BASEPLATE DOWN AND FIXING PIPEWORK. SEE MANUAL FOR TOLERANCES.</p> <p>S'ASSURER QUE LE GROUPE ELECTROPOMPE EST FERMEMENT INSTALLE SUR SON MASSIF. VERIFIER LE LIGNAGE DE L'ACCOUPLLEMENT AVANT ET APRES FIXATION DU SOCLE ET DE LA TUYAUTERIE. VOIR LES TOLERANCES D'ALIGNMENT SUR LA NOTICE</p>	<p>PUMP MUSS AUF FESTEM FUNDAMENT STEHEN. KUPPLUNGSHÄLFEN KORREKT AXIAL AUSRICHTEN. DANN PUMPE AUF GRUNDPLATTE FESTSPANNEN UND ANSCHLUSSLEITUNGEN BEFESTIGEN. TOLERANZEN S. BEDIENUNGSANLEITUNG.</p> <p>ZORG DAT POMPEENHEID OP EEN STEVIGE ONDERGROND OPGESTELD STAAT EN DAT KOPPELING CORRECT UITGELIJNT IS ZOWEL VOOR-ALS NADAT DE GRONDPLAAT MET BOUTEN IS VASTGEZET EN DE LEIDINGEN GEINSTALLEERD ZIJN. ZIE HANDLEIDING VOOR TOELAABARE SPELINGEN.</p>

Oil lubricated units only:

<small>J218JZ262</small>	
<p><b>WARNING</b></p> <p><b>ATTENTION</b></p> <p><b>ACHTUNG</b></p> <p><b>WAARSCHUWING</b></p>	<p>THIS MACHINE MUST BE FILLED WITH OIL BEFORE STARTING</p> <p>CETTE MACHINE DOIT ÊTRE REMPLIE D'HUILE AVANT LA MISE EN MARCHÉ</p> <p>DIESE MASCHINE IST VOR DEM STARTEN MIT ÖL ZÜ FULLEN</p> <p>DEZE MACHINE MOET VOOR HET STARTEN MET OLIE GEVULD WORDEN</p>

## 1.8 Specific machine performance

For performance parameters see section 1.5, *Duty conditions*. Where performance data has been supplied separately to the purchaser these should be obtained and retained with these User Instructions.

### 1.9 Noise level

Attention must be given to the exposure of personnel to the noise, and local legislation will define when guidance to personnel on noise limitation is required, and when noise exposure reduction is mandatory. This is typically 80 to 85 dBA.

The usual approach is to control the exposure time to the noise or to enclose the machine to reduce emitted sound. You may have already specified a limiting noise level when the equipment was ordered, however if no noise requirements were defined, then attention is drawn to the following table to give an indication of equipment noise level so that you can take the appropriate action in your plant.

Pump noise level is dependent on a number of operational factors, flow rate, pipework design and acoustic characteristics of the building, and so the values given are subject to a 3 dBA tolerance and cannot be guaranteed.

Similarly the motor noise assumed in the “pump and motor” noise is that typically expected from standard and high efficiency motors when on load directly driving the pump. Note that a motor driven by an inverter may show an increased noise at some speeds.

If a pump unit only has been purchased for fitting with your own driver then the “pump only” noise levels in the table should be combined with the level for the driver obtained from the supplier. Consult Flowserve or a noise specialist if assistance is required in combining the values.

It is recommended that where exposure approaches the prescribed limit, then site noise measurements should be made.

The values are in sound pressure level  $L_{pA}$  at 1 m (3.3 ft) from the machine, for “free field conditions over a reflecting plane”.

For estimating sound power level  $L_{WA}$  (re 1 pW) then add 14 dBA to the sound pressure value.

Motor size and speed kW (hp)	Typical sound pressure level $L_{pA}$ at 1 m reference 20 $\mu$ Pa, dBA							
	3 550 r/min		2 900 r/min		1 750 r/min		1 450 r/min	
	Pump only	Pump and motor	Pump only	Pump and motor	Pump only	Pump and motor	Pump only	Pump and motor
<0.55(<0.75)	72	72	64	65	62	64	62	64
0.75 (1)	72	72	64	66	62	64	62	64
1.1 (1.5)	74	74	66	67	64	64	62	63
1.5 (2)	74	74	66	71	64	64	62	63
2.2 (3)	75	76	68	72	65	66	63	64
3 (4)	75	76	70	73	65	66	63	64
4 (5)	75	76	71	73	65	66	63	64
5.5 (7.5)	76	77	72	75	66	67	64	65
7.5 (10)	76	77	72	75	66	67	64	65
11(15)	80	81	76	78	70	71	68	69
15 (20)	80	81	76	78	70	71	68	69
18.5 (25)	81	81	77	78	71	71	69	71
22 (30)	81	81	77	79	71	71	69	71
30 (40)	83	83	79	81	73	73	71	73
37 (50)	83	83	79	81	73	73	71	73
45 (60)	86	86	82	84	76	76	74	76
55 (75)	86	86	82	84	76	76	74	76
75 (100)	87	87	83	85	77	77	75	77
90 (120)	87	88	83	85	77	78	75	78
110 (150)	89	90	85	87	79	80	77	80
150 (200)	89	90	85	87	79	80	77	80
200 (270)	①	①	①	①	85	87	83	85
300 (400)			–		87	90	85	86

① The noise level of machines in this range will most likely be of values which require noise exposure control, but typical values are inappropriate.

**Note:** for 1 180 and 960 r/min reduce 1 450 r/min values by 2 dBA. For 880 and 720 r/min reduce 1 450 r/min values by 3 dBA.

## 2 TRANSPORT AND STORAGE

### 2.1 Consignment receipt and unpacking

Immediately after receipt of the equipment it must be checked against the delivery/shipping documents for its completeness and that there has been no damage in transportation. Any shortage and/or damage must be reported immediately to Flowserve Solution group and must be received in writing within one month of receipt of the equipment. Later claims cannot be accepted.

Check any crate, boxes or wrappings for any accessories or spare parts that may be packed separately with the equipment or attached to side walls of the box or equipment.

Each product has a unique serial number. Check that this number corresponds with that advised and always quote this number in correspondence as well as when ordering spare parts or further accessories.

### 2.2 Handling

Boxes, crates, pallets or cartons may be unloaded using fork lift vehicles or slings dependent on their size and construction.

### 2.3 Lifting



A crane must be used for all pump sets in excess of 25 kg (55 lb). Fully trained personnel must carry out lifting, in accordance with local regulations.

Slings, ropes and other lifting gear should be positioned where they cannot slip and where a balanced lift is obtained. The angle between sling or ropes used for lifting must not exceed 60°.

#### 2.3.1 Bare shaft pump

The bare shaft pump should be lifted as shown. Place a sling around the suction nozzle and one around the pump bearing housing using pulled tight choker hitches.

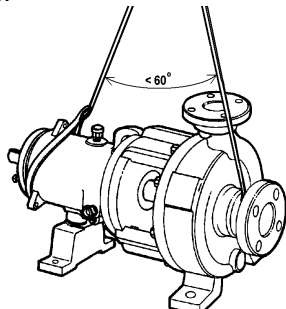

#### 2.3.2 Pump set with folded steel, or polycrete baseplate

Where the baseplate is polycrete or folded steel there are no specific lifting points provided for this complete machine set (unless so identified). Any lifting points that can be seen are provided only for dismantling parts for servicing.

The pump and folded steel, or polycrete, baseplate set should be lifted as shown. With a sling around the pump discharge nozzle, and around the outboard end of the motor frame using choker hitches pulled tight. The sling should be positioned so the weight is not carried through the motor fan hood. Make sure the completion of the choker hitch on the discharge nozzle is toward the coupling end of the pump.

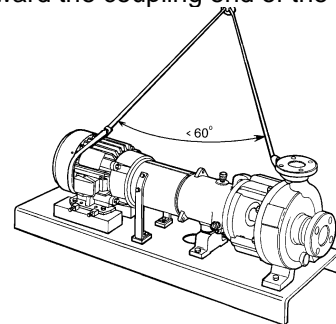

#### 2.3.3 Pump set with cast iron, or fabricated, baseplate

The pump set with cast iron, or fabricated, baseplate which has specific lifting points, should be lifted as shown:

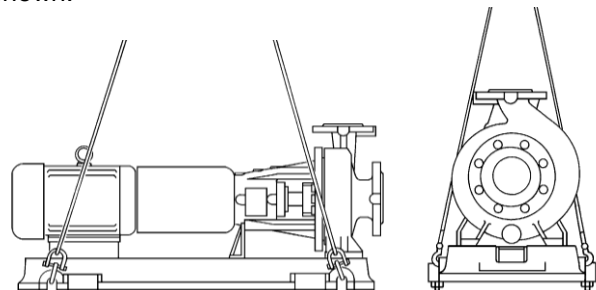

Before lifting the driver alone, refer to the manufacturer's instructions.

### 2.4 Storage



Store the pump in a clean, dry location away from vibration. Leave piping connection covers in place to keep dirt and other foreign material out of pump casing. Turn pump at intervals to prevent false brinelling of the bearing race ways and the seal faces, if fitted, from sticking.

The pump may be stored as above for up to 6 months. Consult Flowserve for preservative actions when a longer storage period is needed.

## 2.5 Recycling and end of product life

At the end of the service life of the product or its parts, the relevant materials and parts should be recycled or disposed of using an environmentally acceptable method and local requirements. If the product contains substances that are harmful to the environment, these should be removed and disposed of in accordance with current regulations. This also includes the liquids and/or gases that may be used in the "seal system" or other utilities.



Make sure that hazardous substances are disposed of safely and that the correct personal protective equipment is used. The safety specifications must be in accordance with the current regulations at all times.

## 3 DESCRIPTION

### 3.1 Configurations

The pump is a modular designed centrifugal pump that can be built to achieve almost all chemical liquid pumping requirements. (See 3.2 and 3.3 below.)

### 3.2 Name nomenclature

The pump size will be engraved on the nameplate typically as below:

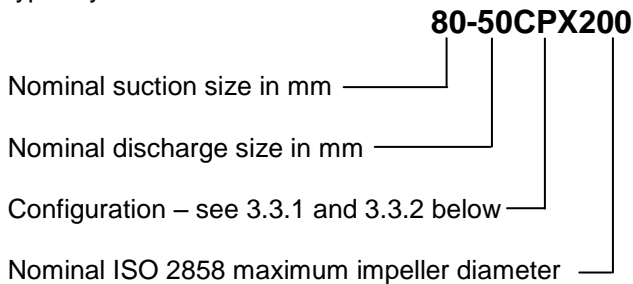

The typical nomenclature above is the general guide to the CPX configuration description. Identify the actual pump size and serial number from the pump nameplate. Check that this agrees with the applicable certification provided.

### 3.3 Design of major parts

#### 3.3.1 Pump casing

The pump casing is designed with a horizontal centreline end inlet and a vertical centreline top outlet which makes it self venting.

In addition, the CPXP pump casing is designed with a self priming action which works on the reflux principle for suction lifts up to 7 m (23 ft).

For ease of maintenance, the pump is constructed so that pipe connectors do not have to be disturbed when internal maintenance is required.

On the CPX, CPXR and CPXP the casing feet pads are underneath the casing. On the CPXN they are on the shaft centreline.

#### 3.3.2 Impeller

An open impeller is fitted. (On the CPXR the impeller is recessed into the back of the casing.)

#### 3.3.3 Shaft

The large diameter stiff shaft, mounted on bearings, has a keyed drive end.

#### 3.3.4 Bearing housing

The bearing housing enables adjustment of impeller face clearance via the bearing carrier jacking screws.

#### 3.3.5 Pump bearings and lubrication

The pump is fitted with ball and or roller type bearings which may be configured differently dependent on use. The bearings may be oil or grease lubricated.

#### 3.3.6 Cover

The cover has spigots between the pump casing and bearing housing for optimum concentricity.

A fully confined gasket forms the seal between the pump casing and the cover.

The covers designs provide improved performance of mechanical seals.

The design enables one of a number of sealing options to be fitted.

#### 3.3.7 Shaft seal

The mechanical seal(s) attached to the drive shaft seals the pumped liquid from the environment. Gland packing may be fitted as an option on the CPX, CPXR and CPXN.

#### 3.3.8 Driver

The driver is normally an electric motor. Different drive configurations may be fitted such as internal combustion engines, turbines, hydraulic motors etc driving via couplings, belts, gearboxes, drive shafts etc.

### 3.3.9 Accessories

Accessories may be fitted when specified by the customer.

Fan cooling is available for high temperature operation. (This is a fan fitted within the coupling guard to blow cooling air over the bearing housing and shaft.)

### 3.4 Performance and operating limits

This product has been selected to meet the specifications of the purchase order. See section 1.5.

The following data is included as additional information to help with your installation. It is typical, and factors such as temperature, materials, and seal type may influence this data. If required, a definitive statement for your particular application can be obtained from Flowserve.

#### 3.4.1 Operating limits

Normal maximum ambient temp. +40 °C (104 °F).  
Maximum pump speed: refer to the nameplate.

## 4 INSTALLATION



Equipment operated in hazardous locations must comply with the relevant explosion protection regulations. See section 1.6.4, *Products used in potentially explosive atmospheres*.

### 4.1 Location

The pump should be located to allow room for access, ventilation, maintenance and inspection with ample headroom for lifting and should be as close as practicable to the supply of liquid to be pumped. Refer to the general arrangement drawing for the pump set.

### 4.2 Part assemblies

On baseplated pump sets the coupling elements are supplied loose. It is the responsibility of the installer to ensure that the pump set is finally lined up as detailed in section 4.5.2, *Alignment methods*.

### 4.3 Foundation



There are many methods of installing pump units to their foundations. The correct method depends on the size of the pump unit, its location and noise and vibration limitations. Non-compliance with the provision of correct foundation and installation may lead to failure of the pump and, as such, would be outside the terms of the warranty.

Ensure the following are met:

- The baseplate should be mounted onto a firm foundation, either an appropriate thickness of quality concrete or sturdy steel framework. (It should NOT be distorted or pulled down onto the surface of the foundation, but should be supported to maintain the original alignment.)
- Install the baseplate onto packing pieces evenly spaced and adjacent to foundation bolts.

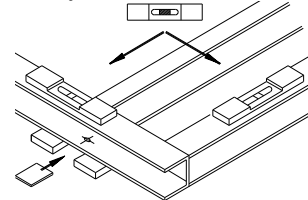

- Level with shims between baseplate and packing pieces.
- The pump and driver have been aligned before dispatch however the alignment of pump and motor half coupling must be checked. If this is incorrect, it indicates that the baseplate has become twisted and should be corrected by re-shimming
- If not supplied, guarding shall be fitted as necessary to meet the requirements of ISO 12100 and EN953.

### 4.4 Grouting

Where applicable, grout in the foundation bolts.

After adding pipework connections and rechecking the coupling alignment, the baseplate should then be grouted in accordance with good engineering practice. Fabricated steel, folded steel and cast iron baseplates can be filled with grout. Polycrystalline baseplates can not be grouted in the same way, see their User Instructions 71569284 (E) for installation and use. If in any doubt, please contact your nearest service centre for advice.

Grouting provides solid contact between the pump unit and foundation, prevents lateral movement of vibrating equipment and dampens resonant vibrations.

Foundation bolts should only be fully tightened when the grout has cured.

### 4.5 Initial alignment

#### 4.5.1 Thermal expansion



The pump and motor will normally have to be aligned at ambient temperature with an allowance for thermal expansion at operating temperature. In pump installations involving high liquid temperatures, the unit should be run at the actual operating temperature, shut down and the alignment checked immediately.



#### 4.5.2 Alignment methods

**⚠ DANGER** Pump and driver must be isolated electrically and the half couplings disconnected.

**⚠ CAUTION** The alignment **MUST** be checked.

Although the pump will have been aligned at the factory it is most likely that this alignment will have been disturbed during transportation or handling. If necessary, align the motor to the pump, not the pump to the motor.

Alignment is achieved by adding or removing shims under the motor feet and also moving the motor horizontally as required. In some cases where the alignment cannot be achieved it will be necessary to move the pump before recommencing the above procedure.

For couplings with narrow flanges use a dial indicator as shown. The alignment values are maximums for continuous service.

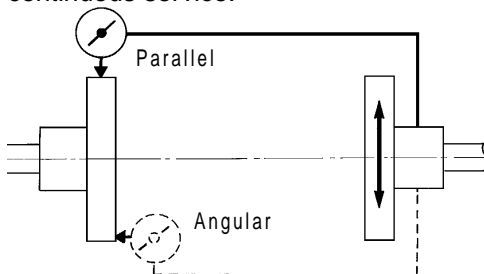

Permissible misalignment limits at working temperature:

- **Parallel alignment**  
- 0.25 mm (0.010 in.) TIR maximum
- **Angular alignment**  
- 0.3 mm (0.012 in.) TIR maximum for couplings not exceeding 100 mm (4 in.) flange diameter  
- 0.5 mm (0.020 in.) TIR maximum for couplings over 100 mm (4 in.) diameter

When checking parallel alignment, the total indicator read-out (TIR) shown is twice the value of the actual shaft displacement.

Align in the vertical plane first, then horizontally by moving motor. Maximum pump reliability is obtained by near perfect alignment of 0.05 - 0.075 mm (0.002 - 0.003 in.) parallel and 0.05 mm (0.002 in.) per 100 mm (4 in.) of coupling flange diameter as angular misalignment.

#### 4.5.3 Check for soft foot

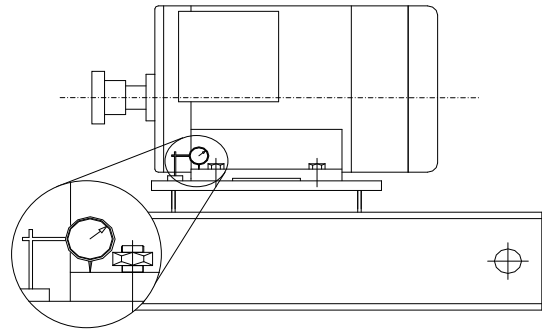

This is a check to ensure that there is no undue stress on the driver holding down bolts; due to non-level baseplate or twisting. To check, remove all shims and clean surfaces and tighten down driver to the baseplate. Set a dial indicator as shown in sketch and loosen off the holding down bolt while noting any deflection reading on the dial test Indicator - a maximum of 0.05 mm (0.002 in.) is considered acceptable but any more will have to be corrected by adding shims. For example, if the dial test indicator shows the foot lifting 0.15 mm (0.006 in.) then this is the thickness of shim to be placed under that foot. Tighten down and repeat the same procedure on all other feet until all are within tolerance.

**⚠** Complete piping as below and see sections 4.7, *Final shaft alignment check* up to and including section 5, *Commissioning, startup, operation and shutdown*, before connecting driver and checking actual rotation.

#### 4.6 Piping

**⚠ CAUTION** Protective covers are fitted to the pipe connections to prevent foreign bodies entering during transportation and installation. Ensure that these covers are removed from the pump before connecting any pipes.

##### 4.6.1 Suction and discharge pipework

**⚠ CAUTION** Never use pump as a support for piping.

Maximum forces and moments allowed on the pump flanges vary with the pump size and type. To minimize these forces and moments that may, if excessive, cause misalignment, hot bearings, worn couplings, vibration and the possible failure of the pump casing, the following points should be strictly followed:

- Prevent excessive external pipe load
- Never draw piping into place by applying force to pump flange connections
- Do not mount expansion joints so that their force, due to internal pressure, acts on the pump flange

 **CAUTION** Ensure piping and fittings are flushed before use.

 **CAUTION** Take any suction lift into account in the available NPSH which must be higher than the required NPSH of the pump.

 Ensure piping for hazardous liquids is arranged to allow pump flushing before removal of the pump.

**4.6.1.1 CPX, CPXR and CPXN only**

In order to minimize friction losses and hydraulic noise in the pipework it is good practice to choose pipework that is one or two sizes larger than the pump suction and discharge. Typically main pipework velocities should not exceed 2 m/s (6 ft/sec) suction and 3 m/s (9 ft/sec) on the discharge.

**4.6.1.2 CPXP self primer only**

The delivery pipework must permit priming air to escape unhindered from the pump during the priming cycle, without back pressure and prevent excessive run-back of liquid on shutdown to minimise syphoning.

Priming air may be vented in one of the following ways:

1. The discharge pipework regulating valve, if fitted, may be partly opened during the priming cycle to freely vent the air.
2. An automatic air release valve may be fitted to the discharge pipework, between the pump and any valves, providing that gases and vapours given off are environmentally safe and acceptable for release into the atmosphere.
3. An air bleed pipe may be run from the discharge pipework, between the pump and any valves, back to the suction tank or sump. This arrangement will require a manual or automatic control during normal operation to prevent continuous re-circulation of the pumped liquid.

**4.6.2 Suction piping**

**4.6.2.1 CPX, CPXR and CPXN suction piping**

- a) The inlet pipe should be one or two sizes larger than the pump inlet bore and pipe bends should be as large a radius as possible.
- b) On suction lift the piping should be inclined up towards the pump inlet with eccentric reducers incorporated to prevent air locks.
- c) On positive suction, the inlet piping must have a constant fall towards the pump.
- d) The pipe next to the pump should be the same diameter as the pump suction and have a minimum of two pipe diameters of straight section between

the elbow and the pump inlet flange. Where the NPSH margin is not large, it is recommended that the pipe straight is 5 to 10 pipe diameter. (See section 10.3, Reference 1.) Inlet strainers, when used, should have a net 'free area' of at least three times the inlet pipe area.

- e) Fitting isolation and non-return valves will allow easier maintenance.
- f) Never throttle pump on suction side and never place a valve directly on the pump inlet nozzle.

**4.6.2.2 CPXP suction piping**

- a) The inlet pipe should be as short as possible, airtight and the smallest volume as practical for the pump flow rate so as to enable quick priming. Where inlet pipe volume is large an inlet foot valve is recommended to retain the liquid in the suction piping and thus reduce the subsequent priming time.
- b) It is recommended that the pump inlet pipe is no larger than the pump inlet bore or such that the suction velocity is in the range of 3 to 5 m/sec (10 to 16 ft/sec). The piping should slope down towards the pump casing suction flange.

- c)  **CAUTION** Take the suction lift into account in the available NPSH, which must be higher than the required NPSH of the pump.
- d) Allow a minimum of two pipe diameters of straight section between the elbow and inlet flange.
- e) Fitting an isolation valve will allow easier maintenance.
- f) Never throttle pump on suction side and never place a valve directly on the pump inlet nozzle.

**4.6.3 Discharge piping**

**4.6.3.1 CPX, CPXR and CPXN discharge piping**

- a) A non-return valve should be located in the discharge pipework to protect the pump from excessive back pressure and hence reverse rotation when the unit is stopped.
- b) Fitting an isolation valve will allow easier maintenance.

**4.6.3.2 CPXP discharge piping**

- a) In order to minimize friction losses and hydraulic noise in the pipework it is good practice to choose pipework that is one or two sizes larger than the pump discharge. Typically main pipework velocities should not exceed 3 m/s (9 ft/sec) on the discharge. Pipework expanders should have a maximum angle of divergence of 9 degrees.

- b) If a non-return valve is located in the discharge pipework then a vent/bleed pipe should be fitted from the discharge pipe back to the sump or source tank.
- c) A regulating valve should be fitted in the discharge pipework unless pump flow is controlled by the delivery system design.

Values are presented in compliance with the ISO 1503 sign convention.

All individual values which are greater than the following values must be referred to Flowserve for approval.

**4.6.4 Allowable nozzle loads**

The pump complies with ISO 5199 shaft deflection limits for the following flange loads. The values are presented in the ISO 5199/ISO 13709 (API 610) format. Please note that the values permitted may be higher or lower than those in ISO 5199; see those specified for the actual pump size.

The values permitted (50 mm and above) meet ISO 13709 (API610) Table 4 values with grouted metallic baseplates. Individual forces and moments up to twice ISO 13709 (API610) Table 4 values may be permitted but only when applied in accordance with the conditions in ISO 13709 (API610) Annex F.

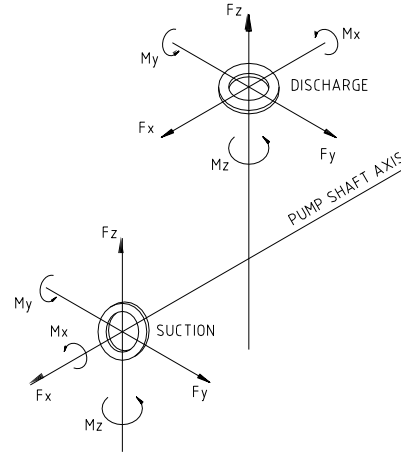

**4.6.4.1 Table of maximum forces and moments (acting simultaneously)**

Size	Forces in N (lbf)						Moments in Nm (lbf-ft)									
	Suction						Discharge						Suction		Discharge	
	Mx	My	Mz	Fx	Fy	Fz	Mx	My	Mz	Fx	Fy	Fz	ΣM	ΣF	ΣM	ΣF
40-25CPX125	840 (620)	450 (330)	640 (470)	1 800 (400)	1 500 (340)	1 200 (270)	190 (140)	180 (130)	190 (140)	460 (100)	370 (80)	580 (130)	1 150 (850)	2 630 (590)	320 (240)	830 (190)
50-32CPX125	930 (690)	470 (350)	700 (520)	1 780 (400)	1 430 (320)	1 160 (260)	340 (250)	170 (130)	260 (190)	520 (120)	430 (100)	660 (150)	1 260 (930)	2 560 (580)	460 (340)	940 (210)
65-40CPX125	1 640 (1 210)	820 (600)	1 230 (910)	2 300 (520)	1 840 (410)	1 500 (340)	560 (410)	280 (210)	420 (310)	860 (190)	700 (160)	1 070 (240)	2 210 (1 630)	3 310 (740)	750 (550)	1 540 (350)
80-50CPX125	1 910 (1 410)	960 (710)	1 430 (1 050)	2 680 (600)	2 140 (480)	1 740 (390)	620 (460)	310 (230)	460 (340)	940 (210)	770 (170)	1 150 (260)	2 570 (1 900)	3 850 (870)	830 (610)	1 670 (380)
100-80CPX125	2 300 (1 700)	1 150 (850)	1 720 (1 270)	3 070 (690)	2 450 (550)	1 990 (450)	1 910 (1 410)	820 (600)	1 430 (1 050)	1 840 (410)	1 740 (390)	2 680 (600)	3 090 (2 280)	4 400 (990)	2 520 (1 860)	3 690 (830)
32-20CPX160	470 (350)	240 (160)	350 (260)	890 (200)	710 (160)	580 (130)	150 (110)	80 (60)	120 (90)	240 (50)	210 (50)	310 (70)	630 (460)	1 280 (290)	210 (150)	440 (100)
40-25CPX160	840 (620)	450 (330)	640 (470)	1 800 (400)	1 500 (340)	1 200 (270)	190 (140)	180 (130)	190 (140)	460 (100)	370 (80)	580 (130)	1 150 (850)	2 630 (590)	320 (240)	830 (190)
50-32CPX160	930 (690)	460 (340)	700 (520)	1 800 (400)	1 500 (340)	1 200 (270)	290 (210)	210 (150)	220 (160)	500 (110)	400 (90)	590 (130)	1 250 (920)	2 630 (590)	420 (310)	870 (200)
65-40CPX160	1 640 (1 210)	820 (600)	1 230 (910)	2 300 (520)	1 840 (410)	1 500 (340)	560 (410)	280 (210)	420 (310)	860 (190)	700 (160)	1 070 (240)	2 210 (1 630)	3 310 (740)	750 (550)	1 540 (350)
80-50CPX160	1 910 (1 410)	960 (710)	1 430 (1 050)	2 680 (600)	2 140 (480)	1 740 (390)	620 (460)	310 (230)	460 (340)	940 (210)	770 (170)	1 150 (260)	2 570 (1 900)	3 850 (870)	830 (610)	1 670 (380)
100-65CPX160	2 670 (1 970)	1 340 (990)	2 000 (1 480)	3 570 (800)	2 850 (640)	2 320 (520)	980 (720)	490 (360)	730 (540)	1 090 (250)	890 (200)	1 370 (310)	3 600 (2 660)	5 120 (1 150)	1 320 (970)	1 960 (440)
125-100CPX160	4 050 (2 990)	2 030 (1 500)	3 040 (2 240)	5 400 (1 210)	4 320 (970)	3 510 (790)	2 300 (1 700)	1 150 (850)	1 720 (1 270)	2 450 (550)	1 990 (450)	3 070 (690)	5 460 (4 030)	7 760 (1 740)	3 090 (2 280)	4 400 (990)
32-20CPX200	470 (350)	340 (250)	350 (260)	890 (200)	710 (160)	580 (130)	150 (110)	80 (60)	120 (90)	240 (50)	210 (50)	310 (70)	680 (500)	1 280 (290)	210 (150)	440 (100)
40-25CPX200	840 (620)	450 (330)	640 (470)	1 800 (400)	1 500 (340)	1 200 (270)	190 (140)	180 (130)	190 (140)	460 (100)	370 (80)	580 (130)	1 150 (850)	2 630 (590)	320 (240)	830 (190)
50-32CPX200	930 (690)	470 (350)	700 (520)	1 800 (400)	1 500 (340)	1 200 (270)	290 (210)	210 (150)	220 (160)	500 (110)	400 (90)	590 (130)	1 260 (930)	2 630 (590)	420 (310)	870 (200)
65-40CPX200	1 790 (1 320)	860 (630)	1 220 (900)	2 680 (600)	2 140 (480)	1 740 (390)	460 (340)	230 (170)	350 (260)	710 (160)	570 (130)	880 (200)	2 330 (1 720)	3 850 (870)	620 (460)	1 270 (290)
80-50CPX200	1 910 (1 410)	960 (710)	1 430 (1 050)	2 680 (600)	2 140 (480)	1 740 (390)	620 (460)	310 (230)	460 (340)	940 (210)	770 (170)	1 150 (260)	2 570 (1 900)	3 850 (870)	830 (610)	1 670 (380)
100-65CPX200	2 670 (1 970)	1 340 (990)	2 000 (1 480)	3 570 (800)	2 850 (640)	2 320 (520)	1 210 (890)	600 (440)	900 (660)	1 350 (300)	1 100 (250)	1 690 (380)	3 600 (2 660)	5 120 (1 150)	1 620 (1 190)	2 430 (550)

Size	Forces in N (lbf)						Moments in Nm (lbf·ft)									
	Suction						Discharge						Suction		Discharge	
	Mx	My	Mz	Fx	Fy	Fz	Mx	My	Mz	Fx	Fy	Fz	ΣM	ΣF	ΣM	ΣF
125-100CPX200	4 710 (3 470)	1 560 (1 150)	3 540 (2 610)	4 140 (930)	5 020 (1 130)	2 690 (600)	2 670 (1 970)	880 (650)	2 000 (1 480)	1 880 (420)	2 320 (520)	3 570 (800)	6 100 (4 500)	7 040 (1 580)	3 450 (2 540)	4 650 (1 050)
40-25CPX250	840 (620)	450 (330)	640 (470)	1 800 (400)	1 500 (340)	1 200 (270)	190 (140)	180 (130)	190 (140)	450 (100)	370 (80)	540 (120)	1 150 (850)	2 630 (590)	320 (240)	790 (180)
50-32CPX250	930 (690)	460 (340)	700 (520)	1 800 (400)	1 500 (340)	1 200 (270)	290 (210)	210 (150)	220 (160)	500 (110)	370 (80)	590 (130)	1 250 (920)	2 630 (590)	420 (310)	860 (190)
65-40CPX250	1 780 (1 310)	860 (630)	1 220 (900)	2 680 (600)	2 140 (480)	1 740 (390)	500 (370)	260 (190)	370 (270)	750 (170)	610 (140)	940 (210)	2 320 (1 710)	3 850 (870)	670 (490)	1 350 (300)
80-50CPX250	1 910 (1 410)	960 (710)	1 430 (1 050)	2 680 (600)	2 140 (480)	1 740 (390)	720 (530)	360 (270)	540 (400)	1 100 (250)	890 (200)	1 370 (310)	2 570 (1 900)	3 850 (870)	970 (720)	1 970 (440)
100-65CPX250	2 670 (1 970)	1 340 (990)	2 000 (1 480)	3 570 (800)	2 850 (640)	2 320 (520)	1 150 (850)	570 (420)	860 (630)	1 290 (290)	1 040 (230)	1 610 (360)	3 600 (2 660)	5 120 (1 150)	1 540 (1 140)	2 310 (520)
125-100CPX250	4 710 (3 470)	1 860 (1 370)	3 540 (2 610)	4 960 (1 120)	5 020 (1 130)	3 220 (720)	2 670 (1 970)	1 060 (780)	2 000 (1 480)	1 880 (420)	2 320 (520)	3 570 (800)	6 180 (4 560)	7 760 (1 740)	3 500 (2 580)	4 650 (1 050)
150-125CPX250	4 710 (3 470)	2 360 (1 740)	3 540 (2 610)	4 960 (1 120)	5 020 (1 130)	3 220 (720)	4 710 (3 470)	1 340 (990)	3 540 (2 610)	2 860 (640)	4 090 (920)	6 280 (1 410)	6 350 (4 680)	7 760 (1 740)	6 040 (4 460)	8 020 (1 800)
200-150CPX250	6 990 (5 160)	3 500 (2 580)	5 240 (3 870)	9 460 (2 130)	7 560 (1 700)	6 150 (1 380)	4 710 (3 470)	2 360 (1 740)	3 540 (2 610)	5 020 (1 130)	4 080 (920)	6 280 (1 410)	9 410 (6 940)	13 580 (3 050)	6 350 (4 680)	9 020 (2 030)
50-32CPX315	930 (690)	470 (350)	700 (520)	1 800 (400)	1 500 (340)	1 200 (270)	460 (340)	230 (170)	350 (260)	720 (160)	580 (130)	890 (200)	1 260 (930)	2 630 (590)	620 (460)	1 280 (290)
65-40CPX315	1 510 (1 110)	840 (620)	1 030 (760)	2 580 (580)	1 940 (440)	1 740 (390)	580 (430)	290 (210)	400 (300)	900 (200)	730 (160)	1 120 (250)	2 010 (1 480)	3 670 (860)	760 (560)	1 610 (360)
80-50CPX315	1 910 (1 410)	960 (710)	1 430 (1 050)	2 680 (600)	2 140 (480)	1 740 (390)	720 (530)	360 (270)	540 (400)	1 100 (250)	890 (200)	1 370 (310)	2 570 (1 900)	3 850 (870)	970 (720)	1 970 (440)
100-65CPX315	2 670 (1 970)	1 340 (990)	2 000 (1 480)	3 570 (800)	2 850 (640)	2 320 (520)	1 640 (1 210)	820 (600)	1 230 (910)	1 840 (410)	1 490 (330)	2 300 (520)	3 600 (2 660)	5 120 (1 150)	2 210 (1 630)	3 300 (740)
125-80CPX315	4 710 (3 470)	1 740 (1 280)	3 540 (2 610)	4 650 (1 050)	5 020 (1 130)	3 020 (680)	2 670 (1 970)	990 (730)	2 000 (1 480)	2 110 (470)	2 320 (520)	3 570 (800)	6 140 (4 530)	7 480 (1 680)	3 480 (2 570)	4 750 (1 070)
150-125CPX315	4 710 (3 470)	2 360 (1 740)	3 540 (2 610)	6 280 (1 410)	5 020 (1 130)	4 080 (920)	4 710 (3 470)	2 360 (1 740)	3 540 (2 610)	5 020 (1 130)	4 090 (920)	6 280 (1 410)	6 350 (4 680)	9 020 (2 030)	6 350 (4 680)	9 020 (2 030)
200-150CPX315	6 990 (5 160)	3 500 (2 580)	5 240 (3 870)	9 460 (2 130)	7 550 (1 700)	6 150 (1 380)	4 710 (3 470)	2 360 (1 740)	3 540 (2 610)	5 020 (1 130)	4 090 (920)	6 280 (1 410)	9 410 (6 940)	13 580 (3 050)	6 350 (4 680)	9 020 (2 030)
100-65CPX400	2 670 (1 970)	1 340 (990)	2 000 (1 480)	3 570 (800)	2 850 (640)	2 320 (520)	1 210 (890)	600 (440)	900 (660)	1 350 (300)	1 100 (250)	1 690 (380)	3 600 (2 660)	5 120 (1 150)	1 620 (1 190)	2 430 (550)
125-80CPX400	4 710 (3 470)	1 740 (1 280)	3 540 (2 610)	4 650 (1 050)	5 020 (1 130)	3 020 (680)	1 310 (970)	710 (520)	1 010 (740)	1 850 (420)	1 500 (340)	2 300 (520)	6 140 (4 530)	7 480 (1 680)	1 800 (1 330)	3 310 (740)
150-125CPX400	4 710 (3 470)	2 360 (1 740)	3 540 (2 610)	6 280 (1 410)	5 020 (1 130)	4 080 (920)	2 670 (1 970)	990 (730)	2 000 (1 480)	2 110 (470)	2 320 (520)	3 570 (800)	6 350 (4 680)	9 020 (2 030)	3 480 (2 570)	4 750 (1 070)
200-150CPX400	6 990 (5 160)	3 500 (2 580)	5 240 (3 870)	9 460 (2 130)	7 550 (1 700)	6 150 (1 380)	4 710 (3 470)	2 360 (1 740)	3 540 (2 610)	5 020 (1 130)	4 090 (920)	6 280 (1 410)	9 410 (6 940)	13 580 (3 050)	6 350 (4 680)	9 020 (2 030)
250-200CPX400	9 950 (7 340)	4 980 (3 670)	7 460 (5 500)	13 420 (3 020)	10 730 (2 410)	8 720 (1 960)	6 990 (5 160)	3 500 (2 580)	5 240 (3 870)	7 560 (1 700)	6 150 (1 380)	9 460 (2 130)	13 400 (9 880)	19 270 (4 330)	9 410 (6 940)	13 580 (3 050)
200-150CPX500	6 990 (5 160)	3 500 (2 580)	5 240 (3 870)	9 460 (2 130)	7 550 (1 700)	6 150 (1 380)	4 710 (3 470)	2 360 (1 740)	3 540 (2 610)	5 020 (1 130)	4 090 (920)	6 280 (1 410)	9 410 (6 940)	13 580 (3 050)	6 350 (4 680)	9 020 (2 030)

The values in the table above must be multiplied by the following factors.

Casing material	Liquid temperature °C (°F)			
	-20 to 100 (-4 to 212)	101 to 200 (213 to 392)	201 to 299 (393 to 570)	300 to 350 (571 to 662)
Austenitic ductile iron Alloy 20 Titanium Titanium Pd	0.8	0.76	0.72	0.68
Nickel	0.5	0.475	0.45	0.425
All other materials	1	0.95	0.9	0.85

#### 4.6.5 Auxiliary piping



The connections that are to be piped up will have been fitted with protective metal or plastic plugs which will need to be removed.

##### 4.6.5.1 CPX, CPXR and CPXN pumps fitted with packed glands

When suction pressure is below ambient pressure and differential head is less than 10 m (32.8 ft), it may be necessary to feed gland packing with liquid to provide lubrication and prevent the ingress of air.

**4.6.5.2 Pumps fitted with mechanical seals**

The conical design of the cover provides excellent liquid circulation around the seal and will not normally require a separate flush for single internal seals. Single seals requiring re-circulation will normally be provided with the auxiliary piping from pump casing already fitted.

Flowserve seal connections are designated as follows:

- Q - quench
- F - flush
- D - drain outlet
- BI - barrier fluid in (double seals)
- BO - barrier fluid out (double seals)
- H - heating jacket
- C - cooling jacket

Covers having an auxiliary quench connection, require connection to a suitable source of liquid flow, low pressure steam or static pressure from a header tank. Recommended pressure is 0.35 bar (5 psi) or less. Check *General arrangement drawing*.

Dual seals, both pressurised and unpressurised, require a barrier liquid between the seals, compatible with the pumped liquid.

With back-to-back double seals, the barrier liquid should be at a minimum pressure of 1 bar (14.5 psi) above the maximum pressure on the pump side of the inner seal. (See chart.) The barrier liquid pressure must not exceed limitations of the seal on the atmospheric side. For toxic service the barrier liquid supply and discharge must be handled safely and in line with local legislation.

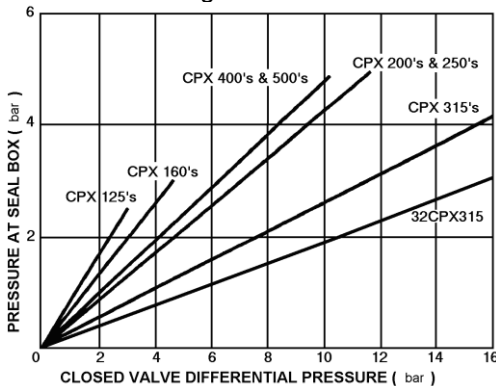

**Notes:**

- a) Total seal pressure is equal to pressure at seal plus suction pressure.
- b) For pumped liquid viscosities greater than 440 Centistokes multiply the differential pressure by 1.25 for 125, 160 and 200 size pumps and by 2.0 for larger sizes.
- c) Differential pressure in bar equals head in metres multiplied by specific gravity all divided by 10.19.
- d) Ensure to check the seal minimum and maximum pressure limits are not exceeded and the pressure is agreed with Flowserve.

Special seals may require modification to auxiliary piping described above. Consult Flowserve if unsure of correct method or arrangement.

For pumping hot liquids, to avoid seal damage, it is recommended that any external flush/cooling supply be continued after stopping the pump.

**4.6.5.3 Pumps fitted with heating/cooling jackets**

Connect the heating/cooling pipes from the site supply. The top connection should be used as the outlet to ensure complete filling/venting of the annulus with heating/cooling liquids; steam is usually in at the top, out at the bottom.

**4.6.6 Final checks**

Check the tightness of all bolts in the suction and discharge pipework. Check also the tightness of all foundation bolts.

**4.7 Final shaft alignment check**

After connecting piping to the pump, rotate the shaft several times by hand to ensure there is no binding and all parts are free. Recheck the coupling alignment, as previously described, to ensure no pipe strain. If pipe strain exists, correct piping.

**4.8 Electrical connections**



**DANGER**

Electrical connections must be made by a qualified Electrician in accordance with relevant local national and international regulations.



It is important to be aware of the EUROPEAN DIRECTIVE on potentially explosive areas where compliance with IEC60079-14 is an additional requirement for making electrical connections.



It is important to be aware of the EUROPEAN DIRECTIVE on electromagnetic compatibility when wiring up and installing equipment on site. Attention must be paid to ensure that the techniques used during wiring/installation do not increase electromagnetic emissions or decrease the electromagnetic immunity of the equipment, wiring or any connected devices. If in any doubt contact Flowserve for advice.



**DANGER**

The motor must be wired up in accordance with the motor manufacturer's instructions (normally supplied within the terminal box) including any temperature, earth leakage, current and other protective devices as appropriate. The identification nameplate should be checked to ensure the power supply is appropriate.



A device to provide emergency stopping must be fitted.

If not supplied pre-wired to the pump unit, the controller/starter electrical details will also be supplied within the controller/starter.

For electrical details on pump sets with controllers see the separate wiring diagram.

**CAUTION** See section 5.4, *Direction of rotation* before connecting the motor to the electrical supply.

#### 4.9 Protection systems

The following protection systems are recommended particularly if the pump is installed in a potentially explosive area or is handling a hazardous liquid. If in any doubt consult Flowserve.

If there is any possibility of the system allowing the pump to run against a closed valve or below minimum continuous safe flow a protection device should be installed to ensure the temperature of the liquid does not rise to an unsafe level.

If there are any circumstances in which the system can allow the pump to run dry, or start up empty, a power monitor should be fitted to stop the pump or prevent it from being started. This is particularly relevant if the pump is handling a flammable liquid.

If leakage of product from the pump or its associated sealing system can cause a hazard it is recommended that an appropriate leakage detection system is installed.

To prevent excessive surface temperatures at bearings it is recommended that temperature or vibration monitoring is carried out.

### 5 COMMISSIONING, START-UP, OPERATION AND SHUTDOWN

**CAUTION** *These operations must be carried out by fully qualified personnel.*

#### 5.1 Pre-commissioning procedure

##### 5.1.1 Lubrication

Determine the mode of lubrication of the pump set, eg grease, oil etc.

**CAUTION** For oil lubricated pumps, fill the bearing housing with correct grade of oil to the correct level, ie sight glass [3856] or constant level oiler bottle [3855].

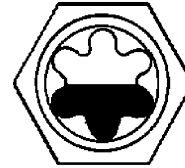

When fitted with a constant level oiler [3855], the bearing housing [3200] should be filled by unscrewing or hinging back the transparent bottle and filling it with oil. Watchdog oilers are self-setting and internally vent balanced. Where an adjustable body Denco oiler is fitted this should be set to the height shown in the following diagram:

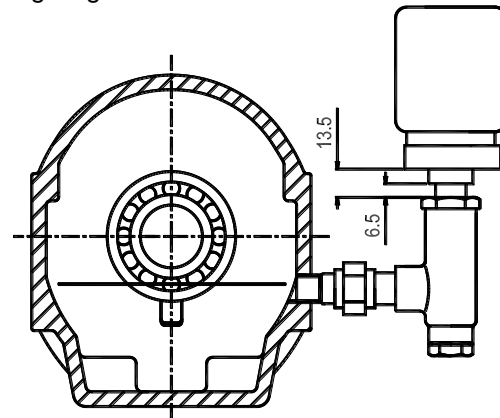

The oil filled bottle should then be refitted so as to return it to the upright position. Filling should be repeated until oil remains visible within the bottle.

Approximate oil volumes are shown in section 5.2.2, *Bearing sizes and capacities.*

Grease lubricated pumps and electric motors are supplied pre-greased.

Where the ambient temperature is very low special lubricants are required. Where oil lubrication is utilized and the ambient is less than -5 °C (23 °F) ensure the oil's pour point is at least 15 °C (27 °F) below the ambient temperature or use oil class SAE 5W-50 or API-SJ and ensure the upper operating range of the oil is then not exceeded. ISO VG 46 oil is generally selected for an initial lubrication schedule.

Other drivers and gearboxes, if appropriate, should be lubricated in accordance with their manuals.

### 5.1.2 Purge / oil mist lubrication

To further limit dirt ingress and dewpoint issues within the bearing housing, a 1/8" connection is available for a low pressure instrument air or nitrogen supply where applicable.



The pressure shall be **0.01-0.02 bar (0.14-0.29 psi)**.

## 5.2 Pump lubricants

### 5.2.1 Recommended oil lubricants

Centrifugal pump lubrication	Oil	Splash / force feed / purge oil mist/ pure oil mist lubrication		
	Viscosity cSt @ 40 °C	32	46	68
	Oil temperature range *	-5 to 65 °C (23 to 149 °F)	<b>-5 to 78 °C (23 to 172 °F)</b>	-5 to 80 °C (23 to 176 °F)
	Designation to ISO 3448 and DIN51524 part 2	ISO VG 32 32 HLP	<b>ISO VG 46 46 HLP</b>	ISO VG 68 68 HLP
Oil companies and lubricants	<b>BP Castrol</b> †	Energol HLP-HM 32	<b>Energol HLP-HM 46</b>	Energol HLP-HM 68
	<b>ESSO</b> †	NUTO HP 32	<b>NUTO HP 46</b>	NUTO HP 68
	<b>ELF/Total</b> †	ELFOLNA DS 32 Azolla ZS 32	<b>ELFOLNA DS 46 Azolla ZS 46</b>	ELFOLNA DS 68 Azolla ZS 68
	<b>LSC (for oil mist)**</b>	LSO 32 (Synthetic oil)	<b>LSO 46 (Synthetic oil)</b>	LSO 68 (Synthetic oil)
	<b>ExxonMobil</b> †	Mobil DTE 24	<b>Mobil DTE 25</b>	Mobil DTE 26
	<b>Q8</b> †	Q8 Haydn 32	<b>Q8 Haydn 46</b>	Q8 Haydn 68
	<b>Shell</b> †	Shell Tellus 32	<b>Shell Tellus 46</b>	Shell Tellus 68
	<b>Chevron Texaco</b> †	Rando HD 32	<b>Rando HD 46</b>	Rando HD 68
	<b>Wintershall (BASF Group)</b> †	Wiolan HS32	<b>Wiolan HS46</b>	Wiolan HS68
<b>Fuchs</b> †	Renolin CL 32	<b>Renolin CL 46</b>	Renolin CL 68	

\* Note that it normally takes 2 hours for bearing temperature to stabilize and the final temperature will depend on the ambient, r/min, pumpage temperature and pump size. Also some oils have a greater viscosity index than the minimum acceptable of 95 (eg Mobil DTE13M) which may extend the minimum temperature capability of the oil. Always check the grade capability where the ambient is less than -5 °C (23 °F).

† Use LSC for oil mist. Oil parameters provide flash point >166 °C (331 °F), density >0.87 @ 15 °C (59 °F), pour point of -10 °C (14 °F) or lower. Normal compounded oils CANNOT be used with oil mist as anti-foam additives need to be avoided. Most oils recommended for wet splash lubrication contain foam inhibitors as well as antioxidants and anticorrosion additives, so they are unsuitable for oil mist. Some synthetic lubricants may attack the Nitrile seals used in a regular bearing housing. The LSC LSO oils are recommended for oil mist applications.

### 5.2.2 Bearing sizes and capacities

Frame size	Grease lubricated medium duty bearings		Grease lubricated heavy duty bearings		Grease lubricated bearing capacities g (oz.)	
	Pump end	Drive end	Pump end	Drive end*	Pump end	Drive end
1	6207 Z C3	3306 Z C3	6207 Z C3	7306 pair back-to-back	6 (0.2)	14 (0.5)
2	6309 Z C3	3309 Z C3	6309 Z C3	7309 pair back-to-back	13 (0.5)	25 (0.9)
3	6311 Z C3	3311 Z C3	6311 Z C3	7311 pair back-to-back	18 (0.6)	35 (1.2)
4	6313 Z C3	3313 Z C3	6313 Z C3	7313 pair back-to-back	20 (0.7)	46 (1.6)

\* Nilos ring fitted into bearing locknut [3712.2]

Frame size	Oil lubricated medium duty bearings		Oil lubricated heavy duty bearings		Oil lubricated optional heavy duty bearings		Frame oil capacity (approx.) litre (fl.oz)
	Pump end	Drive end	Pump end	Drive end	Pump end	Drive end	
1	6207 C3	3306 C3	6207 C3	7306 pair back-to-back	NUP 207 C3	7306 pair back-to-back	0.7 (23)
2	6309 C3	3309 C3	6309 C3	7309 pair back-to-back	NUP 309 C3	7309 pair back-to-back	1.8 (61)
3	6311 C3	3311 C3	6311 C3	7311 pair back-to-back	NUP 311 C3	7311 pair back-to-back	1.4 (47)
4	6313 C3	3313 C3	6313 C3	7313 pair back-to-back	NUP 313 C3	7313 pair back-to-back	2.8 (95)

Note: the bearing sizes do not constitute a purchasing specification.

### 5.2.3 Recommended grease lubricants

Grease	NLGI 2 *	NLGI 3
Temp. range	-20 to +100 °C (-4 to +212 °F)	-20 to +100 °C (-4 to +212 °F)
Designation acc. to DIN	KP2K-25	KP3K-20
<b>BP</b>	Energrease LS-EP2	Energrease LS-EP3
<b>Elf</b>	Multis EP2	Multis EP3
<b>Fuchs</b>	RENOLIT EP2	RENOLIT EP3
<b>ESSO</b>	Beacon EP2	Beacon EP3
<b>Mobil</b>	Mobilux EP2	Mobilux EP3 **
<b>Q8</b>	Rembrandt EP2	Rembrandt EP3
<b>Shell</b>	Alvania EP2	Alvania EP2
<b>Texaco</b>	Multifak EP2	Multifak EP3
<b>SKF</b>	LGEP 2	

\* NLGI 2 is an alternative grease and is not to be mixed with other grades.

\*\* Standard pre-packed grease for fitted antifriction bearings.

#### 5.2.3.1 Food grade grease, when applicable:

NSF H1 Klubersynth UH1 64-62 is the food grade grease option and it is NLGI grade 2.

### 5.2.4 Recommended fill quantities

Refer to section 5.2.2, *Bearing sizes and capacities*.

#### 5.2.5 Lubrication schedule

##### 5.2.5.1 Oil lubricated bearings

Normal oil change intervals are 4 000 operating hours or not more than 6 months. For pumps on hot service or in severely damp or corrosive atmosphere, the oil will require changing more frequently. Lubricant and bearing temperature analysis can be useful in optimizing lubricant change intervals.

The lubricating oil should be a high quality mineral oil having foam inhibitors. Synthetic oils may also be used if checks show that the rubber oil seals will not be adversely affected.

The bearing temperature may be allowed to rise to 50 °C (90 °F) above ambient, but should not exceed 82 °C (180 °F) (API 610 limit). A continuously rising temperature, or an abrupt rise, indicates a fault.

Pumps which handle high temperature liquids may require their bearings to be cooled to prevent bearing temperatures exceeding their limits.

##### 5.2.5.2 Grease lubricated bearings

When grease nipples are fitted, one charge between grease changes is advisable for most operating conditions; ie 2 000 hours interval. Normal intervals between grease changes are 4 000 hours or not more than 6 months. For food grade grease the grease change and relubrication intervals are half that of the conventional greases.

The characteristics of the installation and severity of service will determine the frequency of lubrication. Lubricant and bearing temperature analysis can be useful in optimizing lubricant change intervals.

The bearing temperature may be allowed to rise to 55 °C (99 °F) above ambient, but should not exceed 95 °C (204 °F). For most operating conditions, a quality grease having a lithium soap base and NLGI consistency of No 2 or No 3 is recommended. The drop point should exceed 175 °C (350 °F).

 Never mix greases containing different bases, thickeners or additives.

### 5.3 Open impeller clearance

The impeller clearance is set in the factory. This may require adjustment because of increase in liquid temperature. If piping attachment cause the impeller clearance to change, correct piping. For setting instructions see section 6.7, *Setting impeller clearance*.

### 5.4 Direction of rotation

 Serious damage can result if the pump is started or run in the wrong direction of rotation.

The pump is shipped with the coupling element removed. Ensure the direction of rotation of the motor is correct *before* fitting the coupling element. Direction of rotation must correspond to the direction arrow.

 If maintenance work has been carried out to the site's electricity supply, the direction of rotation should be re-checked as above in case the supply phasing has been altered.

### 5.5 Guarding

 Guarding is supplied fitted to the pump set. In member countries of the EU and EFTA, it is a legal requirement that fasteners for guards must remain captive in the guard to comply with the Machinery Directive 2006/42/EC. When releasing such guards, the fasteners must be unscrewed in an appropriate way to ensure that the fasteners remain captive.

Whenever guarding is removed or disturbed ensure that all the protective guards are securely refitted prior to start-up.

## 5.6 Priming and auxiliary supplies

### 5.6.1 CPX, CPXR and CPXN filling and priming

**CAUTION** Ensure inlet pipe and pump casing is completely full of liquid before starting continuous duty operation.

Priming may be carried out with an ejector, vacuum pump interceptor or other equipment, or by flooding from the inlet source.

When in service, pumps using inlet pipes with foot valves may be primed by passing liquid back from the outlet pipe through the pump.

### 5.6.2 CPXP filling and self priming

**CAUTION** Fill the pump with liquid to be pumped, or compatible liquid, via the filling plug [6569.4], before starting continuous duty operation.

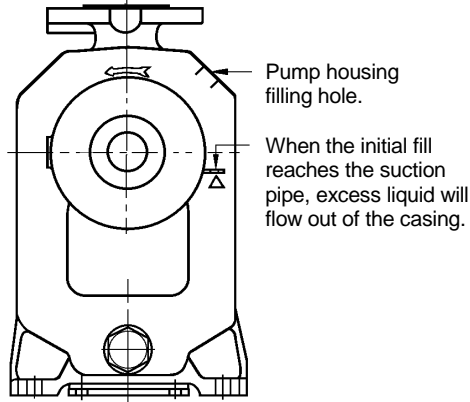

Pump size	Initial fill litre (US gal.)
40-40CPXP125	2.5 (0.65)
80-80CPXP125	6.0 (1.50)
40-40CPXP160	3.0 (0.80)
80-80CPXP160	6.5 (1.75)
40-40CPXP200	5.0 (1.35)
65-65CPXP200	8.5 (2.25)
80-80CPXP250	12.0 (3.20)
100-100CPXP250	36.0 (9.50)
100-100CPXP315	14.8 (3.95)
150-150CPXP315	18.0 (4.80)

The pump has self-priming action for which a separate air pump is not normally required.

### 5.6.3 Auxiliary supplies

**CAUTION** Ensure all electrical, hydraulic, pneumatic, sealant and lubrication systems (as applicable) are connected and operational.

## 5.7 Starting the pump

### 5.7.1 Starting the CPX, CPXR and CPXN

- CAUTION** Ensure flushing and/or cooling/heating liquid supplies are turned ON, before starting pump.
- CLOSE the outlet valve.
- OPEN all inlet valves.
- Prime the pump. Ensure the air has a route to escape from the pump.
- Start motor and check the outlet pressure.
- If the pressure is satisfactory, SLOWLY open the outlet valve.
- CAUTION** Do not run the pump against a closed valve for more than 10 seconds.
- If the pump has to fill the system it may take a short time before the outlet is pressurised.
- If NO pressure, or LOW pressure, STOP the pump. Refer to section 7, *Faults; causes and remedies* for fault diagnosis.

### 5.7.2 Starting the CPXP pump

- CAUTION** Ensure flushing and/or cooling/heating liquid supplies are turned ON, before starting pump.
- CLOSE the outlet valve.
- OPEN all inlet valves.
- CAUTION** Prime the pump. (See section 5.6.2.) The pump casing MUST initially be filled with compatible liquid before starting the unit.
- Damage will occur if the pump is run dry or for prolonged periods with no incoming liquid.
- Subsequent filling should not be necessary unless the pump has been emptied or drained of fluid.
- Start the motor and, if no specific provision has been made in the delivery pipework for evacuating the primed air, open the delivery valve by approximately 10% to allow priming air to escape.
- When the pump has primed, check outlet pressure.
- If the pressure is satisfactory, SLOWLY open the outlet valve.
- It is recommended that the priming time is noted. Priming times in excess of 5 minutes will indicate a pump or system fault. Any noticeable increases in priming time on subsequent starts will also indicate a fault. Irregular use could lead to the risk of 'evaporation' of the priming fluid.
- CAUTION** Do not run the pump with the outlet valve closed for a period longer than 10 seconds.

- l) If the pump has to fill the system it may take a short time before the outlet is pressurized.
- m) If NO pressure, or LOW pressure, STOP the pump. Refer to section 7, *Faults; causes and remedies* for fault diagnosis.

## 5.8 Running the pump

### 5.8.1 Pumps fitted with packed gland

If the pump has a packed gland there must be some leakage from the gland. Gland nuts should initially be finger-tight only. Leakage should take place soon after the stuffing box is pressurised.

 The gland must be adjusted evenly to give visible leakage and concentric alignment of the gland ring to avoid excess temperature. If no leakage takes place the packing will begin to overheat. If overheating takes place the pump should be stopped and allowed to cool before being re-started. When the pump is re-started, check to ensure leakage is taking place at the packed gland.

If hot liquids are being pumped it may be necessary to slacken the gland nuts to achieve leakage.

The pump should be run for 30 minutes with steady leakage and the gland nuts tightened by 10 degrees at a time until leakage is reduced to an acceptable level, normally 30 to 120 drops per minute. Bedding in of the packing may take another 30 minutes.

 Care must be taken when adjusting the gland on an operating pump. Safety gloves are essential.

Loose clothing must not be worn to avoid being caught up by the pump shaft. Shaft guards must be replaced after the gland adjustment is complete.

 Never run gland packing dry, even for a short time.

### 5.8.2 Pumps fitted with mechanical seal

Mechanical seals require no adjustment. Any slight initial leakage will stop when the seal is run in. Before pumping dirty liquids it is advisable, if possible, to run the pump in using clean liquid to safeguard the seal face.

 External flush or quench should be started before the pump is run and allowed to flow for a period after the pump has stopped.

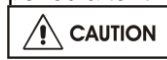
 Never run a mechanical seal dry, even for a short time.

### 5.8.3 Bearings

 If the pumps are working in a potentially explosive atmosphere temperature or vibration monitoring at the bearings is recommended.

If bearing temperatures are to be monitored it is essential that a benchmark temperature is recorded at the commissioning stage and after the bearing temperature has stabilized.

- Record the bearing temperature (t) and the ambient temperature (ta)
- Estimate the likely maximum ambient temperature (tb)
- Set the alarm at (t+tb-ta+5) °C (t+tb-ta+10) °F and the trip at 100 °C (212 °F) for oil lubrication and 105 °C (220 °F) for grease lubrication

It is important, particularly with grease lubrication, to keep a check on bearing temperatures. After start up the temperature rise should be gradual, reaching a maximum after approximately 1.5 to 2 hours.

This temperature should then remain constant or marginally reduce with time. Refer to section 5.2.5 for further information.

### 5.8.4 Normal vibration levels, alarm and trip

For guidance, pumps generally fall under a classification for rigid support machines within the International rotating machinery standards and the recommended maximum levels below are based on those standards.

 Alarm and trip values for installed pumps should be based on the actual measurements (N) taken on the pump in the fully commissioned as new condition. Measuring vibration at regular intervals will then show any deterioration in pump or system operating conditions.

Vibration velocity – unfiltered r.m.s.	Horizontal pumps	
	Motor ≤ 15 kW mm/sec (in./sec)	Motor > 15 kW mm/sec (in./sec)
Normal <b>N</b>	≤ 3.0 (0.12)	≤ 4.5 (0.18)
Alarm <b>N x 1.25</b>	≤ 3.8 (0.15)	≤ 5.6 (0.22)
Shutdown trip <b>N x 2.0</b>	≤ 6.0 (0.24)	≤ 9.0 (0.35)

Where a grease lubricated unit is utilized in a vertical shaft configuration with a duck-foot bend onto the pump suction, the following apply:

Vibration velocity – unfiltered r.m.s	Vertical configurations mm/sec (in./sec)
Normal <b>N</b>	≤ 7.1 (0.28)
Alarm <b>N x 1.25</b>	≤ 9.0 (0.35)
Shutdown trip <b>N x 2.0</b>	≤ 14.2 (0.56)





### 5.8.5 Stop/start frequency

Pump sets are normally suitable for the number of equally spaced stop/starts per hour shown in the table below. Check capability of the driver and control/starting system before commissioning.

Motor rating kW (hp)	Maximum stop/starts per hour
Up to 15 (20)	15
Between 15 (20) and 90 (120)	10
Above 90 (120)	6

Where duty and standby pumps are installed it is recommended that they are run alternately every week.

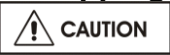
## 5.9 Stopping and shutdown

- a)  Close the outlet valve, but ensure that the pump runs in this condition for no more than a few seconds.
- b) Stop the pump.
- c) Switch off flushing and/or cooling/heating liquid supplies at a time appropriate to the process.
- d)  For prolonged shut-downs and especially when ambient temperatures are likely to drop below freezing point, the pump and any cooling and flushing arrangements must be drained or otherwise protected.

## 5.10 Hydraulic, mechanical and electrical duty

This product has been supplied to meet the performance specifications of your purchase order, however it is understood that during the life of the product these may change. The following notes may help the user decide how to evaluate the implications of any change. If in doubt contact your nearest Flowserve office.

### 5.10.1 Specific gravity (SG)

Pump capacity and total head in metres (feet) do not change with SG, however pressure displayed on a pressure gauge is directly proportional to SG. Power absorbed is also directly proportional to SG. It is therefore important to check that any change in SG will not overload the pump driver or over-pressurize the pump.

### 5.10.2 Viscosity

For a given flow rate the total head reduces with increased viscosity and increases with reduced viscosity. Also for a given flow rate the power absorbed increases with increased viscosity, and reduces with reduced viscosity. It is important that checks are made with your nearest Flowserve office if changes in viscosity are planned.

### 5.10.3 Pump speed

Changing pump speed effects flow, total head, power absorbed, NPSH<sub>R</sub>, noise and vibration. Flow varies in direct proportion to pump speed, head varies as speed ratio squared and power varies as speed ratio cubed. The new duty, however, will also be dependent on the system curve. If increasing the speed, it is important therefore to ensure the maximum pump working pressure is not exceeded, the driver is not overloaded, NPSH<sub>A</sub> > NPSH<sub>R</sub>, and that noise and vibration are within local requirements and regulations.

### 5.10.4 Net positive suction head (NPSH<sub>A</sub>)

NPSH available (NPSH<sub>A</sub>) is a measure of the head available in the pumped liquid, above its vapour pressure, at the pump suction branch.

NPSH required (NPSH<sub>R</sub>) is a measure of the head required in the pumped liquid, above its vapour pressure, to prevent the pump from cavitating. It is important that NPSH<sub>A</sub> > NPSH<sub>R</sub>. The margin between NPSH<sub>A</sub> > NPSH<sub>R</sub> should be as large as possible.

If any change in NPSH<sub>A</sub> is proposed, ensure these margins are not significantly eroded. Refer to the pump performance curve to determine exact requirements particularly if flow has changed.

If in doubt please consult your nearest Flowserve office for advice and details of the minimum allowable margin for your application.

### 5.10.5 Pumped flow

Flow must not fall outside the minimum and maximum continuous safe flow shown on the pump performance curve and or data sheet.

## 6 MAINTENANCE

### 6.1 General



It is the plant operator's responsibility to ensure that all maintenance, inspection and assembly work is carried out by authorized and qualified personnel who have adequately familiarized themselves with the subject matter by studying this manual in detail. (See also section 1.6.)

Any work on the machine must be performed when it is at a standstill. It is imperative that the procedure for shutting down the machine is followed, as described in section 5.9.

Guard fasteners must remain captive during dismantling of guards, as described in section 5.5.

On completion of work all guards and safety devices must be re-installed and made operative again.

Before restarting the machine, the relevant instructions listed in section 5, *Commissioning, start up, operation and shut down* must be observed.

***Oil and grease leaks may make the ground slippery. Machine maintenance must always begin and finish by cleaning the ground and the exterior of the machine.***

If platforms, stairs and guard rails are required for maintenance, they must be placed for easy access to areas where maintenance and inspection are to be carried out. The positioning of these accessories must not limit access or hinder the lifting of the part to be serviced.

When air or compressed inert gas is used in the maintenance process, the operator and anyone in the vicinity must be careful and have the appropriate protection.

Do not spray air or compressed inert gas on skin.

Do not direct an air or gas jet towards other people.

Never use air or compressed inert gas to clean clothes.

Before working on the pump, take measures to prevent an uncontrolled start. Put a warning board on the starting device with the words:

***"Machine under repair: do not start"***.

With electric drive equipment, lock the main switch open and withdraw any fuses. Put a warning board on the fuse box or main switch with the words: ***"Machine under repair: do not connect"***.

Never clean equipment with inflammable solvents or carbon tetrachloride. Protect yourself against toxic fumes when using cleaning agents.

### 6.2 Maintenance schedule



It is recommended that a maintenance plan and schedule is adopted, in line with these User Instructions, to include the following:

- a) Any auxiliary systems installed must be monitored, if necessary, to ensure they function correctly.
- b) Gland packings must be adjusted correctly to give visible leakage and concentric alignment of the gland follower to prevent excessive temperature of the packing or follower.
- c) Check for any leaks from gaskets and seals. The correct functioning of the shaft seal must be checked regularly.
- d) Check bearing lubricant level, and if the hours run show a lubricant change is required.
- e) Check that the duty condition is in the safe operating range for the pump.
- f) Check vibration, noise level and surface temperature at the bearings to confirm satisfactory operation.
- g) Check dirt and dust is removed from areas around close clearances, bearing housings and motors.
- h) Check coupling alignment and re-align if necessary.

Our specialist service personnel can help with preventative maintenance records and provide condition monitoring for temperature and vibration to identify the onset of potential problems.

If any problems are found the following sequence of actions should take place:

- a) Refer to section 7, *Faults; causes and remedies*, for fault diagnosis.
- b) Ensure equipment complies with the recommendations in this manual.
- c) Contact Flowserve if the problem persists.

#### 6.2.1 Routine inspection (daily/weekly)



The following checks should be made and the appropriate action taken to remedy any deviations:

- a) Check operating behaviour. Ensure noise, vibration and bearing temperatures are normal.
- b) Check that there are no abnormal fluid or lubricant leaks (static and dynamic seals) and

that any sealant systems (if fitted) are full and operating normally.

- c) Check that shaft seal leaks are within acceptable limits.
- d) Check the level and condition of oil lubricant. On grease lubricated pumps, check running hours since last recharge of grease or complete grease change.
- e) Check any auxiliary supplies eg heating/cooling (if fitted) are functioning correctly.



Refer to the manuals of any associated equipment for routine checks needed.

**6.2.2 Periodic inspection (six monthly)**



- a) Check foundation bolts for security of attachment and corrosion.
- b) Check pump running records for hourly usage to determine if bearing lubricant requires changing.
- c) The coupling should be checked for correct alignment and worn driving elements.



Refer to the manuals of any associated equipment for periodic checks needed.

**6.2.3 Re-lubrication**

For general guidelines refer to section 5.2.5, *Lubrication schedule*.

Lubricant and bearing temperature analysis can be useful in optimizing lubricant change intervals.

**6.2.4 Mechanical seals**

When leakage becomes unacceptable the seal [4200] will need replacement.

**6.2.5 Gland packing**

The stuffing box split gland [4120] can be completely removed for re-packing or to enable the addition of extra rings of packing. The stuffing box is normally supplied with a lantern ring [4134] to enable a clean or pressurised flush to the centre of the packing. If not required, this can be replaced by an extra 2 rings of packing.

**6.3 Spare parts**

**6.3.1 Ordering of spares**

Flowserve keeps records of all pumps that have been supplied. When ordering spares the following information should be quoted.

- 1) Pump serial number.
- 2) Pump size.
- 3) Part name – taken from section 8.
- 4) Part number – taken from section 8.

- 5) Number of parts required.

The pump size and serial number are shown on the pump nameplate.

To ensure continued satisfactory operation, replacement parts to the original design specification should be obtained from Flowserve. Any change to the original design specification (modification or use of a non-standard part) will invalidate the pump's safety certification.

**6.3.2 Storage of spares**

Spares should be stored in a clean dry area away from vibration. Inspection and re-treatment of metallic surfaces (if necessary) with preservative is recommended at 6 monthly intervals.

**6.4 Recommended spares**

For two years operation (as per VDMA 24296).

Part no.	Designation	Number of pumps (including stand-by)						
		2	3	4	5	6/7	8/9	10(+)
2200	Impeller	1		2		3		30%
2100	Shaft	1		2		3		30%
3712.1	Bearing locknut	1		2		3		50%
2400	Sleeve (if fitted)	2		3		4		50%
3011	Radial ball bearing	1		2		3		50%
3013	Thrust bearing	1		2		3		50%
4590.1 *	Gasket	4	6	8	9	12	150%	
4610.1	O-ring	4	6	8	9	12	150%	
4610.2	O-ring	4	6	8	9	10	100%	
2540.2	Deflector	1		2		3		30%
4130	Gland packing	2		3		4		40%
4134	Lantern ring	1		2		3		30%
4200	Mechanical seals	1		2		3		30%
-	Power end	-	-	-	-	1	2	

\* Note: for CPXR replace with the following part:

4590.1	Gasket	8	12	16	18	24	300%
--------	--------	---	----	----	----	----	------

**Additional spares for keyed impeller option**

2912.1 / 2912.2	Impeller nut	1		2		3		30%
4610.4	O-ring (if sleeve fitted)	2		3		4		50%
4610.5	O-ring	4	6	8	9	12	150%	
6700.2	Key	1		2		3		30%

### 6.5 Tools required

A typical range of tools that will be required to maintain these pumps is listed below.

Readily available in standard tool kits, and dependent on pump size:

- Open ended spanners (wrenches) to suit up to M 24 screws/nuts
- Socket spanners (wrenches), up to M 24 screws
- Allen keys, up to 10 mm (A/F)
- Range of screwdrivers
- Soft mallet

More specialized equipment:

- Bearing pullers
- Bearing induction heater
- Dial test indicator
- C-spanner (wrench) - for removing shaft nut. (If difficulties in sourcing are encountered, consult Flowserve.)
- Coupling grip/shaft spanner

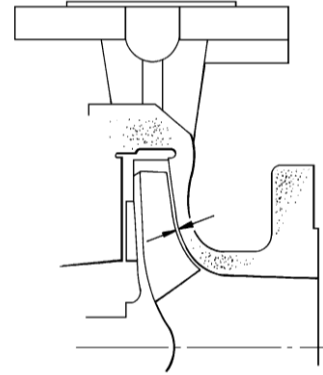

### 6.6 Fastener torques

Fastener	Screw size	Torque Nm (lbf ft)
All except where otherwise stated	M8	16 (12)
	M10	25 (18)
	M12	35 (26)
	M16	80 (59)
	M20	130 (96)
Impeller nut	M12	16 (12)
	M16	41 (31)
	M22	106 (79)
	M24	135 (100)

**CAUTION** Non-metallic gaskets incur creep relaxation - before commissioning the pump check and retighten fasteners to tightening torques stated.

### 6.7 Setting impeller clearance

This procedure may be required after the pump has been dismantled or a different clearance is required.

Before carrying out this procedure ensure that the mechanical seal(s) [4200] fitted can tolerate a change in their axial setting, otherwise it will be necessary to dismantle the unit and reset the seal axial position after adjusting the impeller clearance.

Temp °C (°F)	Clearance mm (in.)			
	Impellers up to 210 mm	Impellers 211 mm to 260 mm	Impellers over 260 mm (except *)	(*)150CPX400 (*)200CPX400 (*)150CPX500
50 (122)	0.3 (0.012)	0.4 (0.016)	0.5 (0.020)	1.0 (0.040)
100 (212)	0.4 (0.016)	0.5 (0.020)	0.6 (0.024)	1.0 (0.040)
150 (302)	0.5 (0.020)	0.6 (0.024)	0.7 (0.028)	1.1 (0.044)
200 (392)	0.6 (0.024)	0.7 (0.028)	0.8 (0.032)	1.2 (0.048)
250 (482)	0.7 (0.028)	0.8 (0.032)	0.9 (0.036)	1.3 (0.052)

- Disconnect the coupling if it has limited axial flexibility
- Record the gap between the bearing carrier [3240] and bearing housing [3200] using feeler gauges.
- Loosen the bearing carrier screws [6570.2] and back off the bearing carrier 2 mm (0.08 in.) using the jacking screws [6570.3].

#### For CPX, CPXN and CPXP

- Tighten the bearing carrier screws [6570.2] evenly, drawing the bearing carrier towards the bearing housing, until the impeller [2200] contacts the pump casing. [1100] Turn the shaft [2100], during this procedure, until a detectable rub is obtained. This is the zero clearance position.
- Set a dial indicator to zero on the shaft end or measure the bearing carrier to bearing housing gap and record the measurement.
- Slacken the bearing carrier screws [6570.2].
- Tighten jacking screws [6570.3] evenly (about one flat at a time) until the dial indicator or feeler gauge shows the correct impeller clearance from the zero clearance position. This clearance should be between 0.3 and 2 mm (0.008 and 0.080 in.) depending on the nature of the pumped fluid. (See table above.)
- Evenly tighten the bearing carrier screws [6570.2] keeping the dial indicator or feeler gauges reading the correct setting. Then tighten the hex nuts [6580.1] to lock the jacking screws in position.

**For CPXR only**

**Note:** The impeller does not have a fine front clearance setting and adjustment of the impeller is not normally required.

- d) Tighten the jacking screws [6570.3] evenly, pushing the bearing carrier away from the bearing housing, until the impeller [2200] contacts the cover. [1220] Turn the shaft [2100], during this procedure, until a detectable rub is obtained. This is the zero clearance position.
- e) Set a dial indicator to zero on the shaft end or measure the bearing carrier to bearing housing gap and record the measurement.
- f) Slacken the jacking screws [6570.3].
- g) Tighten bearing carrier screws [6570.2] evenly (about one flat at a time) until the dial indicator or feeler gauge shows the correct impeller clearance from the zero clearance position. This clearance should be 1.5 - 2 mm (0.06 - 0.08 in.) (See drawing.)
- h) Tighten the jacking screws [6570.3] until they contact the bearing carrier, keeping the dial indicator or feeler gauges reading the correct setting. Then tighten the hex nuts [6580.1] to lock the jacking screws in position.

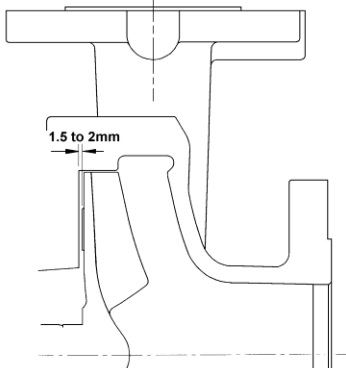

**For all pump types**

- i) Compare the original and final gaps between the bearing carrier and bearing housing to check if the movement of the shaft has exceeded the seal capability (over/under compression of seal). Re-position the seal to correct this.
- j) Check that the shaft [2100] can turn freely without binding.
- k) If a cartridge seal [4200] is fitted it should be reset at this point.
- l) Ensure the coupling distance between shaft ends (DBSE) is correct. Reset/re-align if necessary.

**6.8 Disassembly**

Refer to *Safety* section before dismantling the pump.

**CAUTION** Before dismantling the pump for overhaul, ensure genuine Flowserve replacement parts are available.

Refer to sectional drawings for part numbers and identification. See section 8, *Parts lists and drawings*.

**6.8.1 Bearing housing**

To remove, proceed as follows:

- a) Disconnect all auxiliary pipes and tubes where applicable.
- b) Remove coupling guard and disconnect coupling.
- c) If oil lubricated frame, drain oil by removing drain plug [6569.3].
- d) Record the gap between the bearing carrier and bearing housing so that this setting can be used during workshop assembly.
- e) Place hoist sling through bearing housing window.
- f) Remove casing screws [6570.1] and support foot [3134] to baseplate screws.
- g) Remove bearing housing assembly from pump casing [1100].  
The two threaded holes in the bearing housing flange can be used for jacking screws to assist with removal.
- h) Remove pump casing gasket [4590.1] and discard. A replacement gasket will be required for assembly.
- i) Clean gasket mating surfaces.

**Note:** On CPXP diffuser casing sizes it is not normally necessary to remove the diffuser [1410, 4590.2 and 6570.5].

**6.8.2 Impeller removal**

NEVER APPLY HEAT TO REMOVE THE IMPELLER. TRAPPED OIL OR LUBRICANT MAY CAUSE AN EXPLOSION.

**6.8.2.1 Impeller removal with threaded on impeller**

- a) Ensure the pump bearing housing is firmly fixed to the work bench.
- b) Fit a chain wrench or bolt a bar to the holes in the coupling half, or fit a keyed shaft wrench directly to the shaft. Make sure the wrench or bar can not slip.
- c) Turn the shaft [2100] counter-clockwise as viewed from the drive end of the shaft with the wrench.



- d) Give the shaft a quick turn clockwise to sharply strike the wrench handle against the work bench surface or a wooden block. A few sharp strikes by the handle onto the bench/wooden block will free the impeller from the shaft.
- e) Alternatively, twist the impeller by firmly grabbing hold of the impeller and twist it counter-clockwise. To make the wrench handle impact on the work bench. This method require the use of metal mesh reinforced gloves.
- f) Remove and discard the impeller O-ring [4610.1]. Use a new O-ring for assembly.

**6.8.2.2 Impeller removal with key drive impeller**

- a) Remove impeller nut [2912.1/2912.2] complete with O-ring [4610.5], which should be discarded. (A new O-ring will be required for assembly.)
- b) Pull impeller [2200] off shaft [2100].
- c) Remove impeller key [6700.2].
- d) Remove impeller sealing gasket [4590.4] and discard. (A new sealing gasket will be required for assembly.)

**6.8.3 Cover [1220] and seal [4200]**

The seal manufacturer's instructions should be followed for dismantling and assembly, but the following guidance should assist with most seal types:

- a) Remove shaft guard [7450].
- b) Remove the seal gland nuts, if a separate seal gland is fitted, and slide the seal gland away.
- c) Remove the cover nuts [6580.2].
- d) Loosen the grub screws (used in most mechanical seals).
- e) Carefully pull off the seal cover and mechanical seal rotating element(s).
- f) Remove the cover [1220].
- g) Remove shaft sleeve [2400] (if fitted).
- h) On non-cartridge seals the stationary seat remains in the cover/ seal gland with its sealing member. Remove only if damaged or worn out.
- i) On pumps fitted with gland packing, the packing and lantern ring should be removed only if the packing is to be replaced.

**6.8.4 Bearing housing [3200]**

- a) Pull off the pump half of the coupling and remove the coupling key.
- b) Remove support foot [3134] (if necessary).
- c) Remove the pump side liquid deflector [2540.2] and/or labyrinth seal rotary half (depending on option fitted).
- d) Slacken the nuts [6580.1] and remove bearing carrier screws [6570.2].
- e) Tighten bearing carrier jacking screws [6570.3] evenly to initiate bearing carrier release.

- f) Remove bearing carrier and shaft assembly from the bearing housing [3200] by pulling it towards the coupling end.
- g) Remove bearing circlip [6544](or bearing carrier lock nut [3712.2] if paired angular contact bearings are fitted).

**Note:**

Bearing carrier lock nuts [3712.2] are left-hand thread.

- h) Remove drive side liquid deflector and/or labyrinth seal rotary half (depending on option fitted).
- i) Remove bearing carrier [3240].
- j) Remove pump side bearing [3011].
- k) Release the self locking drive side bearing nut [3712.1] and remove drive side bearing [3013].

**Note:**

When pressing bearings off the shaft, use force on the inner race only.

**6.9 Examination of parts**



Used parts must be inspected before assembly to ensure the pump will subsequently run properly. In particular, fault diagnosis is essential to enhance pump and plant reliability.

**6.9.1 Casing [1100], cover [1220] and impeller [2200]**

Inspect for excessive wear, pitting, corrosion, erosion or damage and any sealing surface irregularities. Replace as necessary.

**6.9.2 Shaft and sleeve (if fitted) [2100, 2400]**

Replace if grooved or pitted. With the bearing mounting diameters (or bearing outer) supported by V-blocks, check that the shaft runouts are within 0.025 mm (0.001 in.) at the coupling end and 0.050 mm (0.002 in.) at the impeller end.

**6.9.3 Gaskets and O-rings [4590, 4610]**

After dismantling, discard and replace.

**6.9.4 Bearings [3011,3013]**

It is recommended that bearings are not re-used after any removal from the shaft.

The bearings and lubricant are to be inspected for contamination and damage. If oil bath lubrication is utilized, these provide useful information on operating conditions within the bearing housing.



If bearing damage is not due to normal wear and the lubricant contains adverse contaminants, the cause should be corrected before the pump is returned to service.

### 6.9.5 Bearing labyrinths/isolators [4330]

Labyrinth seals and bearing isolators should be inspected for damage but are normally non-wearing parts and can be re-used.

Bearing seals are not totally leak free devices. Oil from these may cause staining adjacent to the bearings.

### 6.9.6 Bearing housing and carrier [3200, 3240]

Inspect the bearing carrier circlip groove. Ensure it is free from damage and that housing lubrication passages are clear.

Replace grease nipples or the filter breather (where fitted) if damaged or clogged. On oil lubricated versions, the oil level sight glass [3856] should be replaced if oil stained.

## 6.10 Assembly

To assemble the pump consult the sectional drawings. See section 8, *Parts lists and drawings*.

Ensure threads, gasket and O-ring mating faces are clean. Apply thread sealant to non-face sealing pipe thread fittings.

### 6.10.1 Bearing housing and rotating element assembly

- Clean the inside of the bearing housing [3200], bearing carrier [3240] and bores for bearings.
- Attach bearing housing support foot [3134].
- Fit the thrust ball bearing [3013] on to shaft [2100]. The double row thrust bearing will not normally have a single filling slot, as such bearings are limited to taking thrust in only one direction.

**Note:**

If such a bearing replacement is used, it must be positioned on the shaft so that the bearing filling slot faces the impeller end of the shaft.

If the pair of angular contact thrust bearings are to be fitted, these must be mounted back-to-back, as shown below:

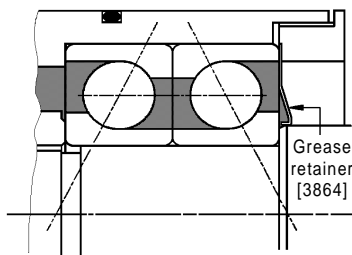

Grease retainer (clearance type) is only fitted on grease lubricated units

The following methods are recommended for fitting the bearings onto the shaft:

**Method 1:** Use a hotplate, hot bath, oven or induction heater to heat the bearing race so it can easily be placed in position then allowed to shrink and grip the shaft. It is important that the temperature is not raised above 100 °C (212 °F).

**Method 2:** Press the bearing onto the shaft using equipment that can provide a steady, even load to the inner race. Take care to avoid damaging the bearing and shaft.

- With bearings at ambient temperature, screw on to the shaft the self-locking bearing locknut [3712.1] (with its polyamide insert facing away from the bearing) until tight.
- With double row thrust bearings place the bearing circlip [6544] over the shaft, with the tapered face facing the impeller end.
- With the pair of angular contact thrust bearing option, the bearing locknut [3712.2] (and Nilos ring [3864] if grease lubricated unit) should be placed on the shaft before fitting the pump radial bearing, having the larger diameter end facing the impeller end.
- Fit pump radial ball bearing [3011] onto the shaft using Method 1 or 2 above.
- With the NUP roller bearing option, the loose ring should be against the shaft shoulder.

**Note:**

On grease lubricated units the bearing shields shall be facing the other bearing. See below.

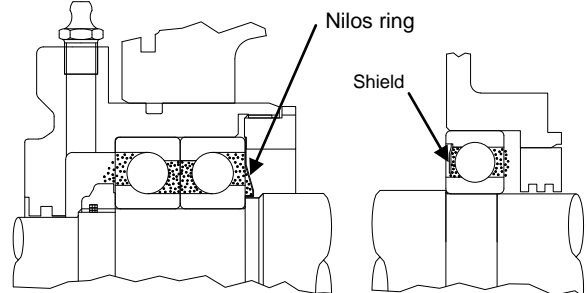

- Fit O-ring [4610.2] on the bearing carrier. Lightly lubricate the bearing carrier bore and O-ring.
- Ensure the shaft keyway edges are free of burrs. During installation, use tape or similar over the keyway to avoid damaging the drive side bearing seals.
- Slide the bearing carrier [3240] onto the shaft/bearing assembly and insert bearing circlip [6544] into the carrier groove or screw up the bearing locknut [3712.2].
- On grease lubricated pumps, pump grease through the grease nipple in the bearing carrier [3240] until grease is visible in the bearing races.
- Check shaft [2100] for free rotation.

- n) Install the shaft assembly into the bearing housing [3200] until the gap is approx. 5 mm (0.2 in.).

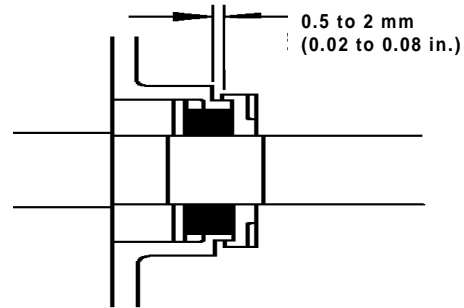
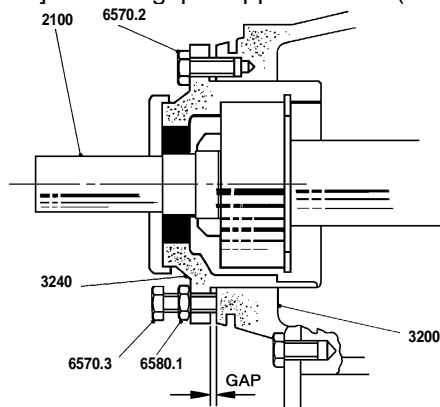

- o) Fit the bearing carrier screws [6570.2] but do not tighten.
- p) Fit the labyrinth ring [4330] (if used) into the bearing housing ensuring the drain hole faces the bearing and is at the 6 o'clock position.
- q) Press drive side liquid deflector [2540.1] and pump side liquid deflector [2540.2] onto shaft where applicable. These should be set 0.5 to 2 mm (0.02 to 0.08 in.) (light contact for elastomer type) from the bearing carrier and bearing housing respectively.
- r) The pump side deflector [2540.2] (this feature is integral with some proprietary labyrinth seals) should only be set in its final position after setting the shaft axial position.
- s) Temporarily fit the cover [1220] to the bearing housing. The shaft [2100] may now be positioned in relation to the cover face, as shown below:

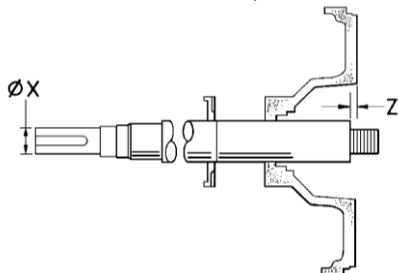

Bearing housing	Dia. X mm (in.)	Z mm (in.)
Frame 1	24 (0.945)	9 (0.354)
Frame 2	32 (1.260)	17 (0.669)
Frame 3	42 (1.654)	9 (0.354)
Frame 4	48 (1.890)	22 (0.866)

- x) The pump side deflector [2540.2] may then be moved towards the bearing housing and set with its clearance.

### 6.10.2 Cover and seal assembly

- Extreme cleanliness is required. The sealing faces and shaft [2100] or sleeve [2400] surface must be free from scratches or other damage.
- Refer to section 6.11, *Seal arrangements* for seal diagrams.
- Carefully press the stationary seat into the cover [1220] or mechanical seal cover [4213], ensuring that the seating ring is not deformed. Where an anti-rotation pin is fitted ensure that correct engagement with the slot is achieved.
- Place any separate seal cover over the shaft.
- Refer to manufacturer's instructions to position the mechanical seal rotating elements. Tighten any drive screws in the seal drive collar. For precise compression most cartridge seals should be set after complete pump assembly.
- Fit the cover [1220] into the bearing housing [3200] and tighten all fasteners.

### 6.10.3 Gland packing assembly

- Assemble the gland packing [4130] into the cover [1220] before fitting on to the shaft [2100].
- Stagger the joints in the gland packing by 90 degrees to each other.
- The lantern ring halves [4134], if required, should be positioned mid-way along the packing.
- Position the gland [4120] squarely against the last ring and tighten the gland nuts finger-tight only. Install into bearing housing assembly and fit the two screws to hold the cover in place.
- Check that the shaft rotates freely.

### 6.10.4 Impeller assembly and setting

#### 6.10.4.1 Impeller assembly and setting

- Fit a new O-ring [4610.1] into the impeller [2200] using a small amount of grease to hold it in place. Apply anti-galling compound (which does not contain copper) to the impeller thread to help subsequent removal.
- Assemble impeller onto the shaft.

- c) Tighten the impeller. Use the same method as in disassembly but rotating in opposite direction. A few sharp strikes will tighten it to the correct level.

**6.10.4.2 Impeller assembly with key drive impeller**

- a) Fit a new impeller sealing gasket [4590.4] against shaft shoulder.
- b) Fit impeller key [6700.2].
- c) Assemble impeller onto the shaft.
- d) Fit a new O-ring [4610.5] into the impeller nut [2912.1/2912.2] groove.
- e) Apply anti-galling compound (which does not contain copper) to the impeller nut threads to help any subsequent removal.
- f) Fit impeller nut onto the shaft [2100] and torque up.

**6.10.5 Assembly of bearing housing into casing**

- a) Fit a new gasket [4590] into the casing [1100].
- Note:**
- On the CPXR a new gasket is required each side of the distance ring [2510.2].
- b) Install the bearing housing assembly into the pump casing. Coat the screws [6570.1] with anti-galling compound and tighten into casing.
  - c) Check impeller front clearance against original setting or process requirement and adjust as necessary. (See section 6.7, *Setting impeller clearance.*)
  - d) Ensure that all other items have been re-attached and all fasteners tightened, then follow the instructions in the sections on *Installation* and *Commissioning*.

**6.11 Sealing arrangements**

The following section shows details of the seal arrangements. The dimensions provided are for non-step balanced mechanical seals conforming to EN 12757 L1K and L1N. Contact your nearest Flowserve sales office or service centre if you require further information, such as a mechanical seal dimensional drawing, or are unsure of the specific arrangement supplied. Refer also to section 4.6.5, *Auxiliary piping*.

**6.11.1 Single seal types**

**6.11.1.1 Single stepped balanced seal**

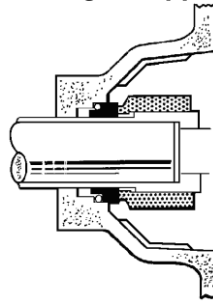

**6.11.1.2 Single unbalanced (or inherently balanced) seal**

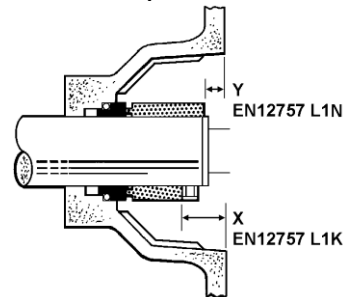

Bearing housing	Setting dimension (mm)	
	X	Y
Frame 1	23.5	11.0
Frame 2	34.0	19.0
Frame 3	33.5	11.0
Frame 4	51.5	24.0

**6.11.1.3 Single seal with external neck bush**

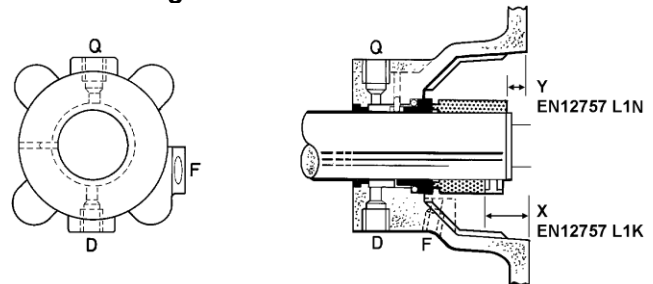

- Q - Rp ¼ in. quench
- D - Rp ¼ in. drain
- F - Rp ¼ in. flush

Bearing housing	Setting dimension (mm)	
	X	Y
Frame 1	23.5	11.0
Frame 2	34.0	19.0
Frame 3	33.5	11.0
Frame 4	51.5	24.0

**6.11.1.4 Single seal with external lip seal**

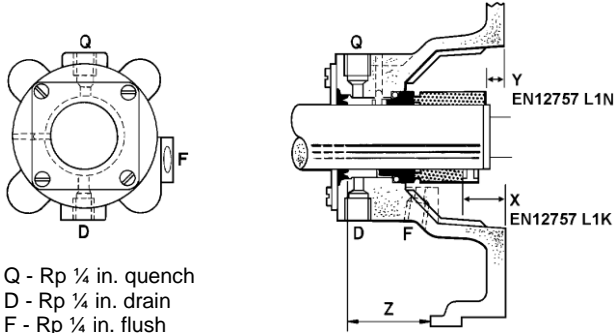

Q - Rp ¼ in. quench  
 D - Rp ¼ in. drain  
 F - Rp ¼ in. flush  
 Z - Position of lip seal hard sleeve

A wear sleeve shall be fitted on the shaft to protect it from wear and to supply a good running surface for the lip seal. The flange of the wear sleeve shall be towards the drive end of the shaft.

**Note:** Fit the wear sleeve as specified in the instructions supplied with it and remove the sleeve flange..

Bearing housing	Setting dimension (mm)	
	X	Y
Frame 1	23.5	11.0
Frame 2	34.0	19.0
Frame 3	33.5	11.0
Frame 4	51.5	24.0

Pump size	Setting dimension Z (mm)			
	Frame 1	Frame 2	Frame 3	Frame 4
125	41.5	-	-	-
160	41.5	49.0	-	-
200	36.5	49.0	-	-
250	-	44.0	45.0	-
315	-	44.0	45.0	65.0
400	-	-	36.5	57.0
500	-	44.0	45.0	65.0

**6.11.1.5 Single internal seal with internal and external neck bush**

Q - Rp ¼ in. quench  
 D - Rp ¼ in. drain  
 F - Rp ¼ in. flush

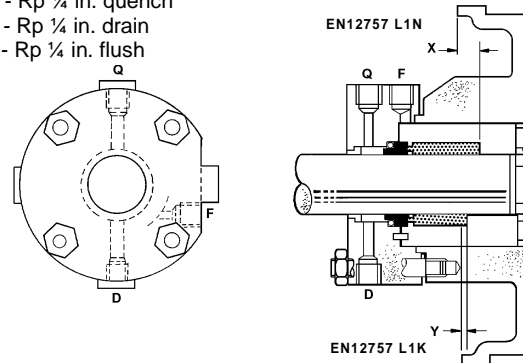

Pump size	Setting dimensions (mm)							
	Frame 1		Frame 2		Frame 3		Frame 4	
	X	Y	X	Y	X	Y	X	Y
125	12.5	0	-	-	-	-	-	-
160	12.5	0	5.5	-9.5	-	-	-	-
200	17.5	5.0	5.5	-9.5	-	-	-	-
250	-	-	10.6	-4.4	18.3	-4.3	-	-
315	-	-	10.6	-4.4	18.3	-4.3	-4.7	-32.3
400	-	-	-	-	27.0	4.3	3.5	-24.0
500	-	-	10.6	-4.4	18.3	-4.3	-4.7	-32.3

**6.11.2 Cartridge seal types**

**6.11.2.1 Cartridge seal in conical cover**

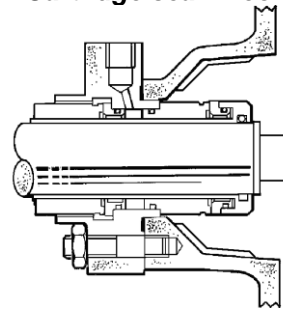

**6.11.2.2 Hooked sleeve cartridge seal**

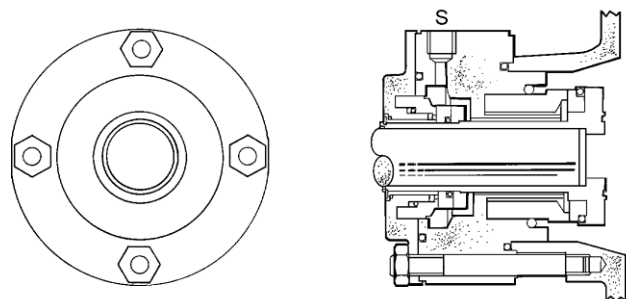

For S see seal supplier's instructions.



### 6.11.3 Tandem seal types

#### 6.11.3.1 Tandem seal with Flowserve eccentric pumping annulus circulation

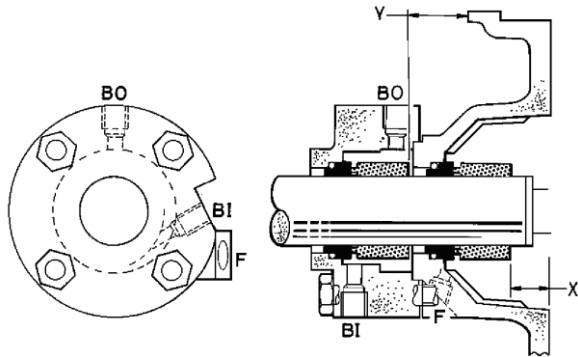

BI - Rp ¼ in. barrier liquid inlet  
 BO - Rp ¼ in. barrier liquid outlet  
 F - Rp ¼ in. flush

Pump size	Setting dimensions (mm)							
	Frame 1		Frame 2		Frame 3		Frame 4	
	X	Y	X	Y	X	Y	X	Y
125	20.0	31.5	-	-	-	-	-	-
160	20.0	31.5	28.0	41.5	-	-	-	-
200	20.0	26.5	28.0	41.5	-	-	-	-
250	-	-	28.0	36.4	27.5	33.7	-	-
315	-	-	28.0	36.4	27.5	33.7	45.5	56.7
400	-	-	-	-	27.5	25.3	45.5	48.3
500	-	-	28.0	36.4	27.5	33.7	45.5	56.7

### 6.11.5 External seal types

#### 6.11.5.1 External seal

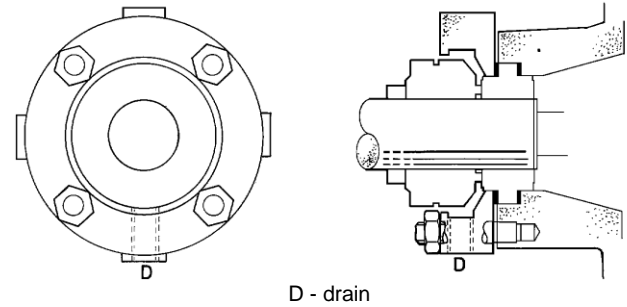

D - drain

### 6.11.6 Packed gland seal types

#### 6.11.6.1 Packed gland with fibre packing

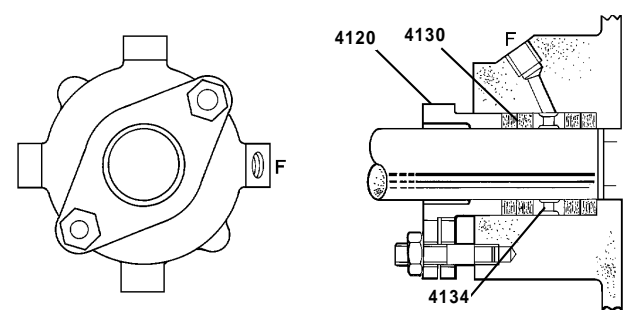

F - Rp ¼ in. flush

### 6.11.4 Double seal types

#### 6.11.4.1 Double back-to-back seal with Flowserve eccentric pumping annulus circulation

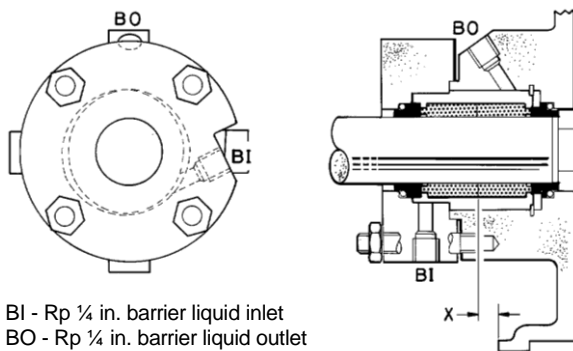

BI - Rp ¼ in. barrier liquid inlet  
 BO - Rp ¼ in. barrier liquid outlet

Pump size	Setting dimension X (mm)			
	Frame 1	Frame 2	Frame 3	Frame 4
125	11.0	-	-	-
160	11.0	17.5	-	-
200	6.0	17.5	-	-
250	-	12.4	14.4	-
315	-	12.4	14.3	32.3
400	-	-	5.7	24.0
500	-	12.4	14.3	32.3





## 8 PARTS LISTS AND DRAWINGS

### 8.1 CPX and CPXN

#### 8.1.1 CPX sectional drawing

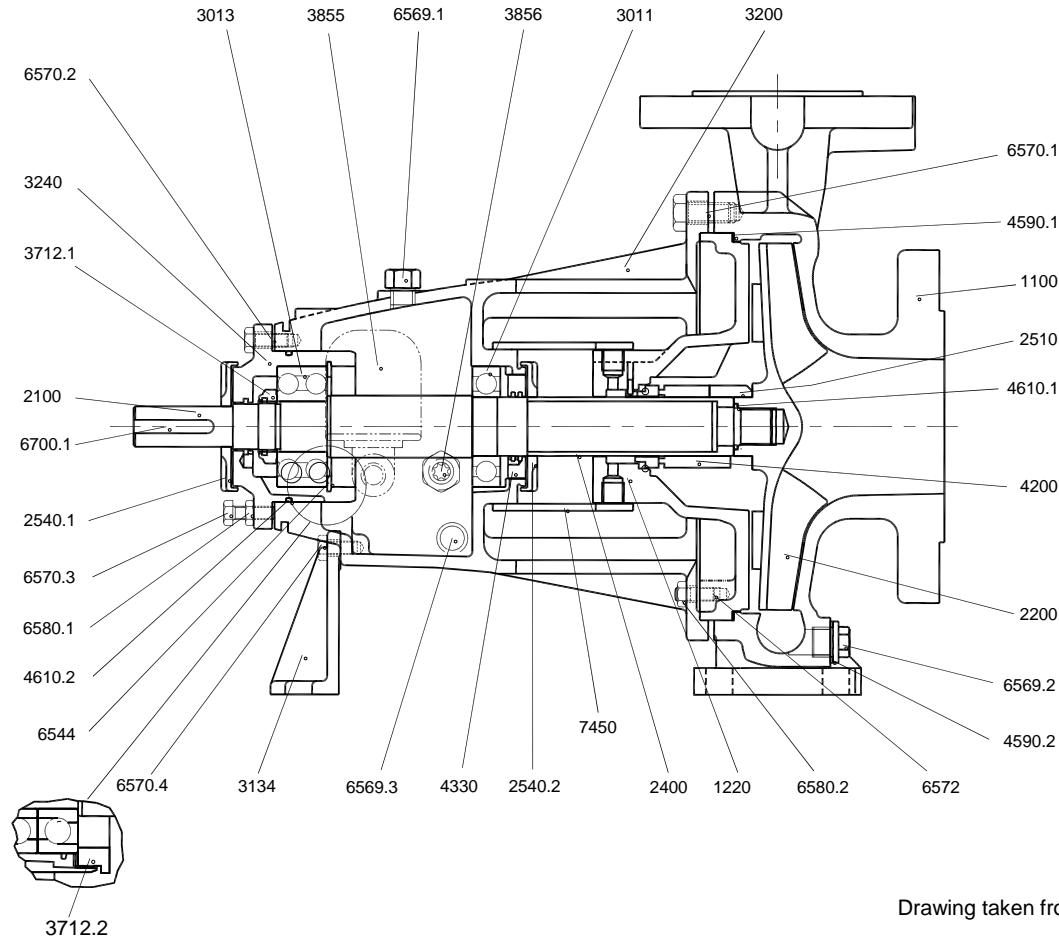

Drawing taken from B731/491, sheet 1, rev G

#### 8.1.2 CPX parts list

Item	Description
1100	Casing
1220	Cover
2100	Shaft
2200	Impeller
2400	Sleeve *
2510	Distance ring
2540.1	Deflector (liquid)
2540.2	Deflector (liquid)
3011	Radial ball bearing
3013	Thrust ball bearing
3134	Support foot
3200	Bearing housing
3240	Bearing carrier
3712.1	Bearing locknut
3712.2	Bearing locknut
3855	Constant level oiler *
3856	Oil sight gauge
4200	Mechanical seal
4330	Labyrinth ring

4590.1	Gasket
4590.2	Gasket *
4610.1	O-ring
4610.2	O-ring
6544	Circlip
6569.1	Plug (filler)
6569.2	Plug *
6569.3	Plug (magnetic)
6570.1	Screw
6570.2	Screw
6570.3	Screw
6570.4	Screw
6572	Stud
6580.1	Nut
6580.2	Nut
6700.1	Key
7450	Guard

Items not illustrated

3853.1	Grease nipples (grease lubrication only) *
3853.2	Grease nipples (grease lubrication only) *

\* Standard option

**8.1.3 CPXN sectional drawing**

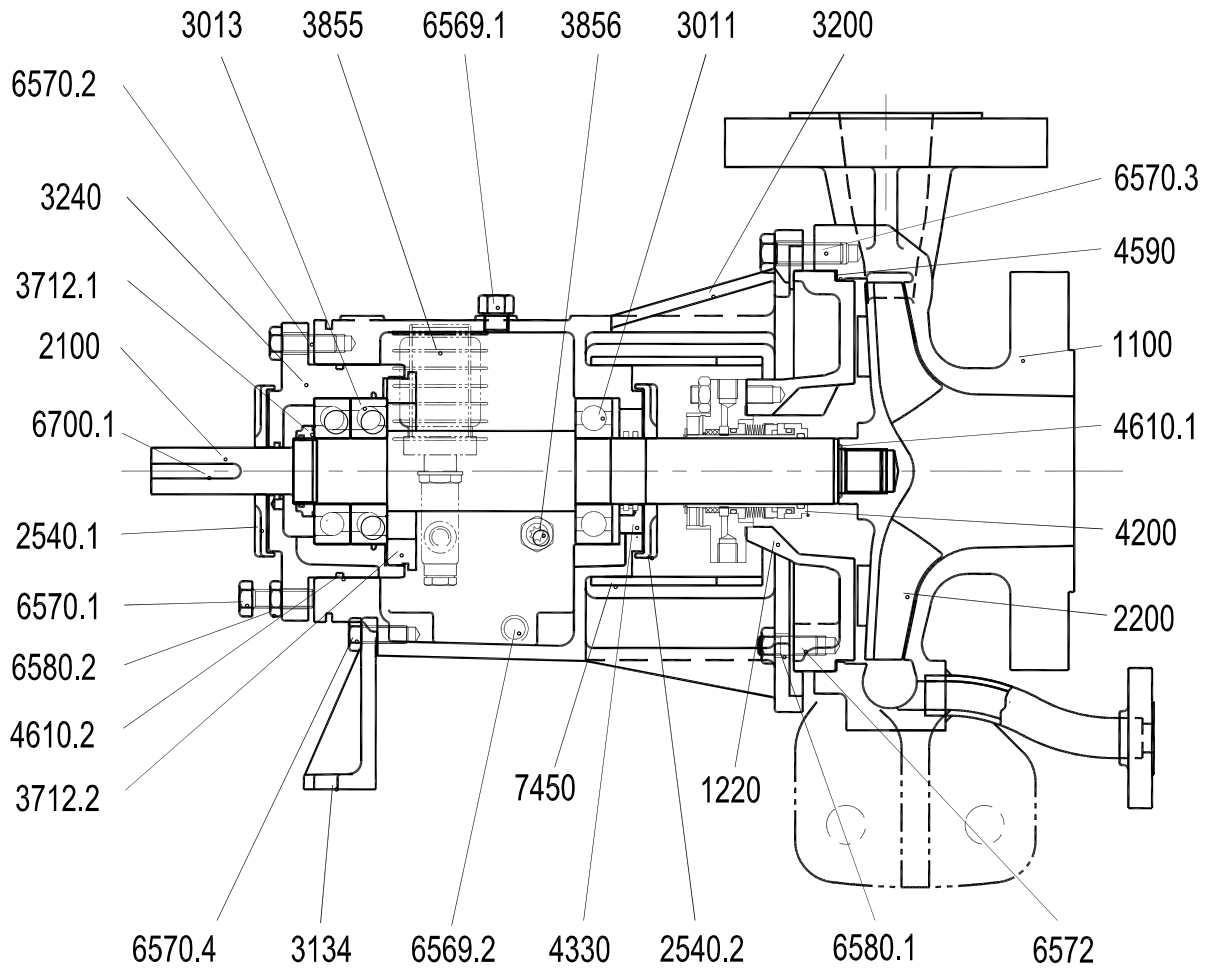

Drawing taken from C128/001, sheet 1, rev B

**8.1.4 CPXN parts list**

Item	Description
1100	Casing
1220	Cover
2100	Shaft
2200	Impeller
2540.1	Deflector (liquid)
2540.2	Deflector (liquid)
3011	Radial ball bearing
3013	Thrust ball bearing
3134	Support foot
3200	Bearing housing
3240	Bearing carrier
3712.1	Bearing locknut
3712.2	Bearing locknut
3855	Constant level oiler
3856	Oil sight gauge
4200	Mechanical seal

4330	Labyrinth ring
4590	Gasket
4610.1	O-ring
4610.2	O-ring
6544	Circlip
6569.1	Plug (filler)
6569.2	Plug (magnetic)
6570.1	Screw
6570.2	Screw
6570.3	Screw
6570.4	Screw
6572	Stud
6580.1	Nut
6580.2	Nut
6700.1	Key
7450	Guard

Items not illustrated

2400	Sleeve *
------	----------

\* Standard option



## 8.2 CPXR

### 8.2.1 CPXR sectional drawing

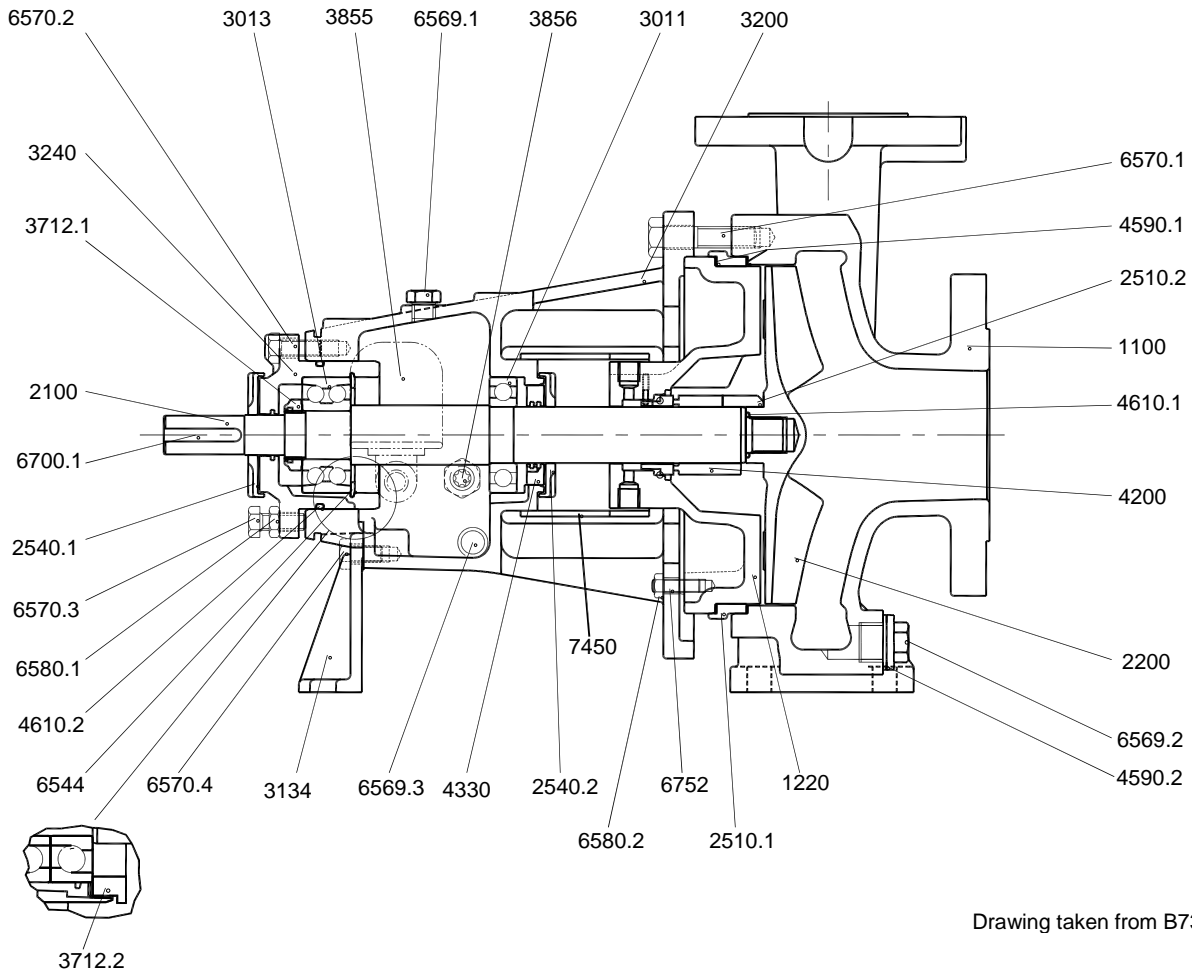

Drawing taken from B731/724, rev E

### 8.2.2 CPXR parts list

Item	Description
1100	Casing
1220	Cover
2100	Shaft
2200	Impeller
2510.1	Distance ring
2510.2	Distance ring
2540.1	Deflector (liquid)
2540.2	Deflector (liquid)
3011	Radial ball bearing
3013	Thrust ball bearing
3134	Support foot
3200	Bearing housing
3240	Bearing carrier
3712.1	Bearing locknut
3712.2	Bearing locknut
3855	Constant level oiler (oil lubrication only) *
3856	Oil sight gauge
4200	Mechanical seal
4330	Labyrinth ring

4590.1	Gasket
4590.2	Gasket *
4610.1	O-ring
4610.2	O-ring
6544	Circlip
6569.1	Plug (filler)
6569.2	Plug *
6569.3	Plug (magnetic)
6570.1	Screw
6570.2	Screw
6570.3	Screw
6570.4	Screw
6572	Stud
6580.1	Nut
6580.2	Nut
6700.1	Key
7450	Guard

Items not illustrated

2400	Sleeve *
3853.1	Grease nipples (grease lubrication only) *
3853.2	Grease nipples (grease lubrication only) *

\* Standard option

### 8.3 CPXP

#### 8.3.1 CPXP sectional drawing

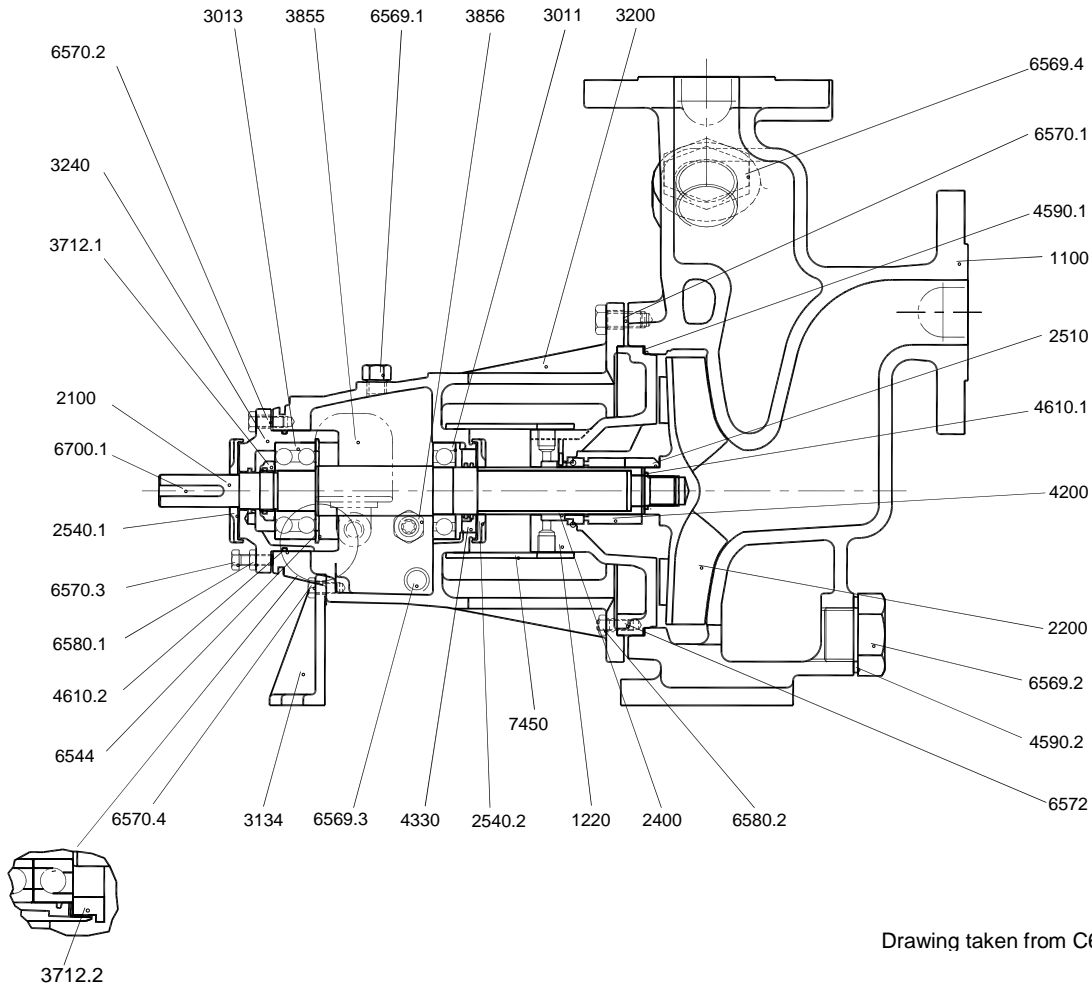

Drawing taken from C665/001, sheet 5, rev C

#### 8.3.2 CPXP parts list

Item	Description
1100	Casing
1220	Cover
2100	Shaft
2200	Impeller
2400	Sleeve *
2510	Distance ring
2540.1	Deflector (liquid)
2540.2	Deflector (liquid)
3011	Radial ball bearing
3013	Thrust ball bearing
3134	Support foot
3200	Bearing housing
3240	Bearing carrier
3712	Bearing locknut
3855	Constant level oiler *
3856	Oil sight gauge
4200	Mechanical seal
4330	Labyrinth ring
4590.1	Gasket

4590.2	Gasket *
4610.1	O-ring
4610.2	O-ring
6544	Circlip
6569.1	Plug (filler)
6569.2	Plug *
6569.3	Plug (magnetic)
6569.4	Plug (filler)
6570.1	Screw
6570.2	Screw
6570.3	Screw
6570.4	Screw
6572	Stud
6580.1	Nut
6580.2	Nut
6700.1	Key
7450	Guard

Items not illustrated

3853.1	Grease nipples (grease lubrication only) *
3853.2	Grease nipples (grease lubrication only) *

\* Standard option

**8.3.3 CPXP sizes with diffuser-casing**

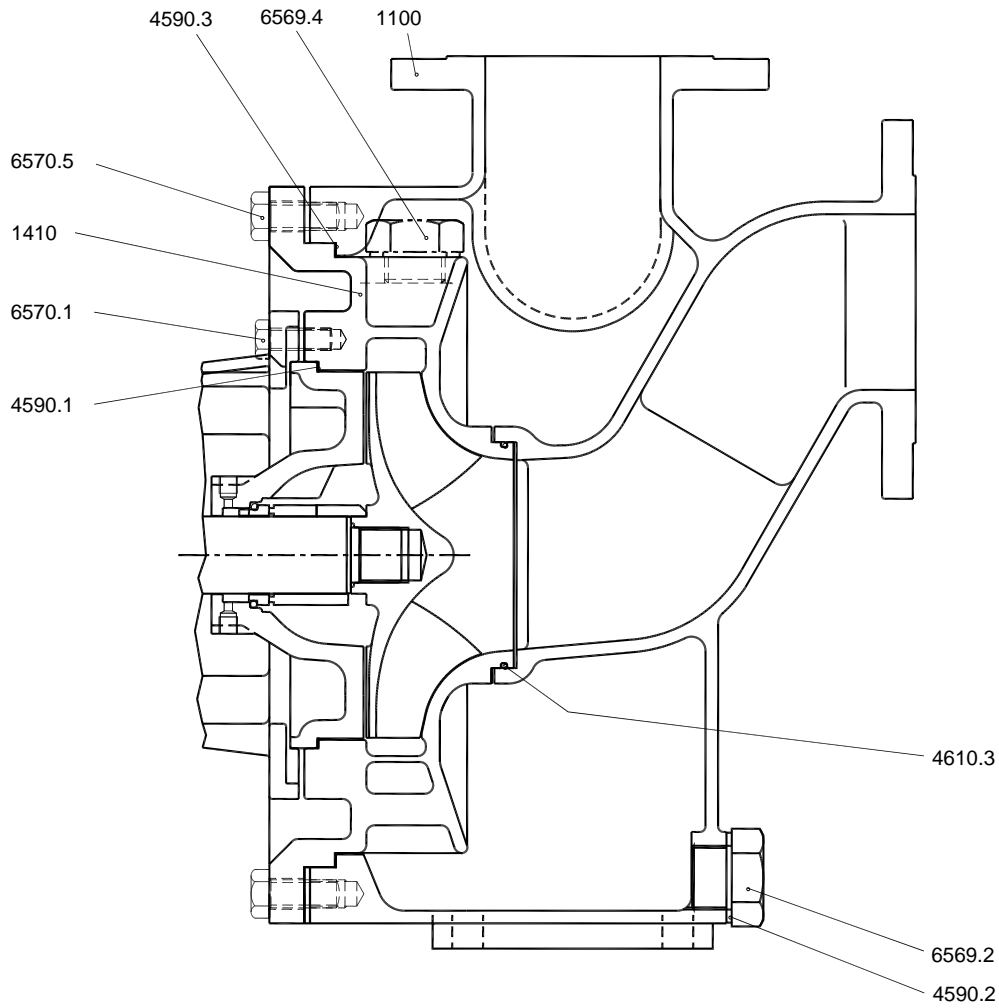

Drawing taken from C665/001, sheet 9, rev C

**8.3.4 CPXP diffuser casing parts list**

Item	Description
1100	Casing
1410	Diffuser
4590.1	Gasket
4590.2	Gasket
4590.3	Gasket
4610.3	O-ring
6569.2	Plug *
6569.4	Plug (filler)
6570.1	Screw
6570.5	Screw

\* Standard option

### 8.4 CPX, CPXR, CPXN and CPXP additional details

#### 8.4.1 CPX, CPXR, CPXN and CPXP bearing housing sealing details

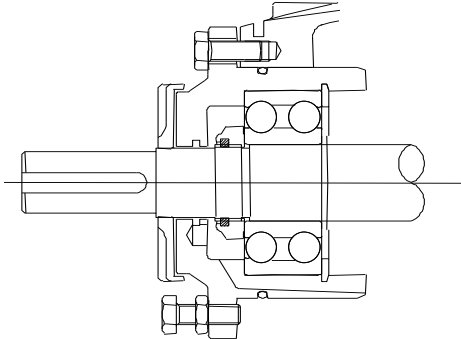

Frame 1 and 2

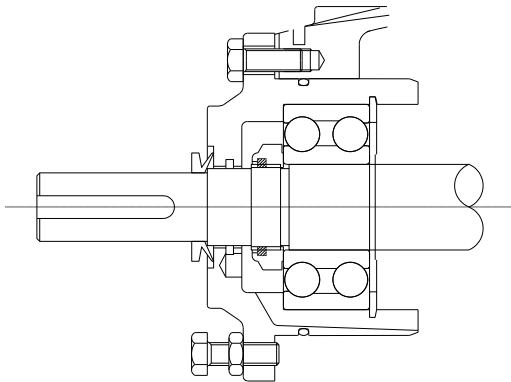

Frame 3 and 4

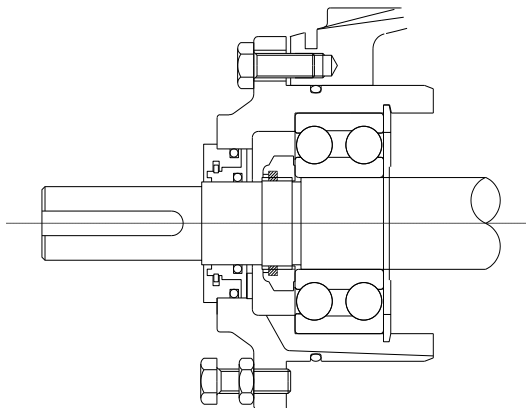

Frame 1 to 4 proprietary labyrinth/face seals (where fitted)

#### 8.4.2 CPX, CPXR, CPXN and CPXP key drive impeller option

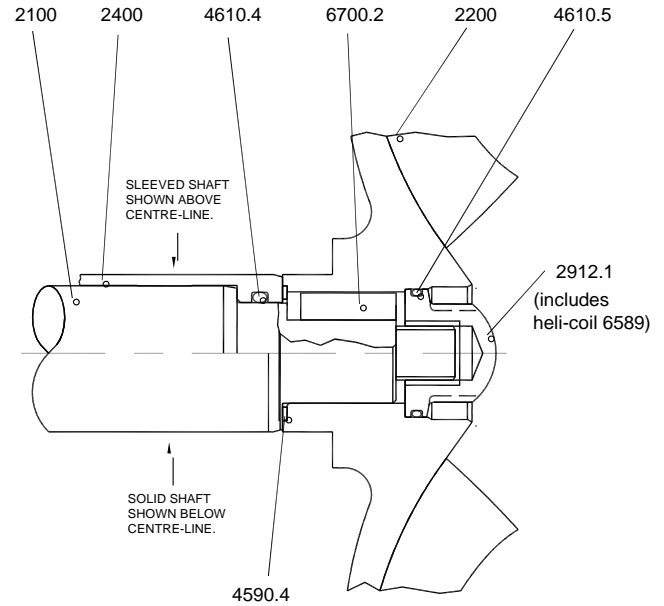

Drawings taken from B731/1644, sheet 1, rev -

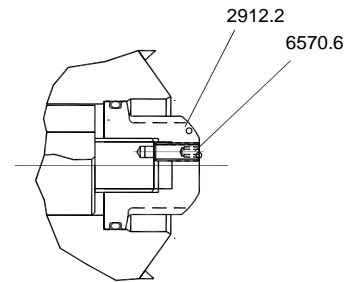

Key drive design for 304/316 stainless steel and above, secure screw with suitable sealant (For example Loctite 577)

Item	Description
2100	Shaft
2200	Impeller
2400	Sleeve (if fitted)
2912.1	Impeller nut
2912.2	Impeller nut
4590.4	Gasket
4610.4	O-ring (if sleeve fitted)
4610.5	O-ring
6570.6	Screw
6700.2	Key

## 8.5 Parts interchangeability

### 8.5.1 CPX parts interchangeability

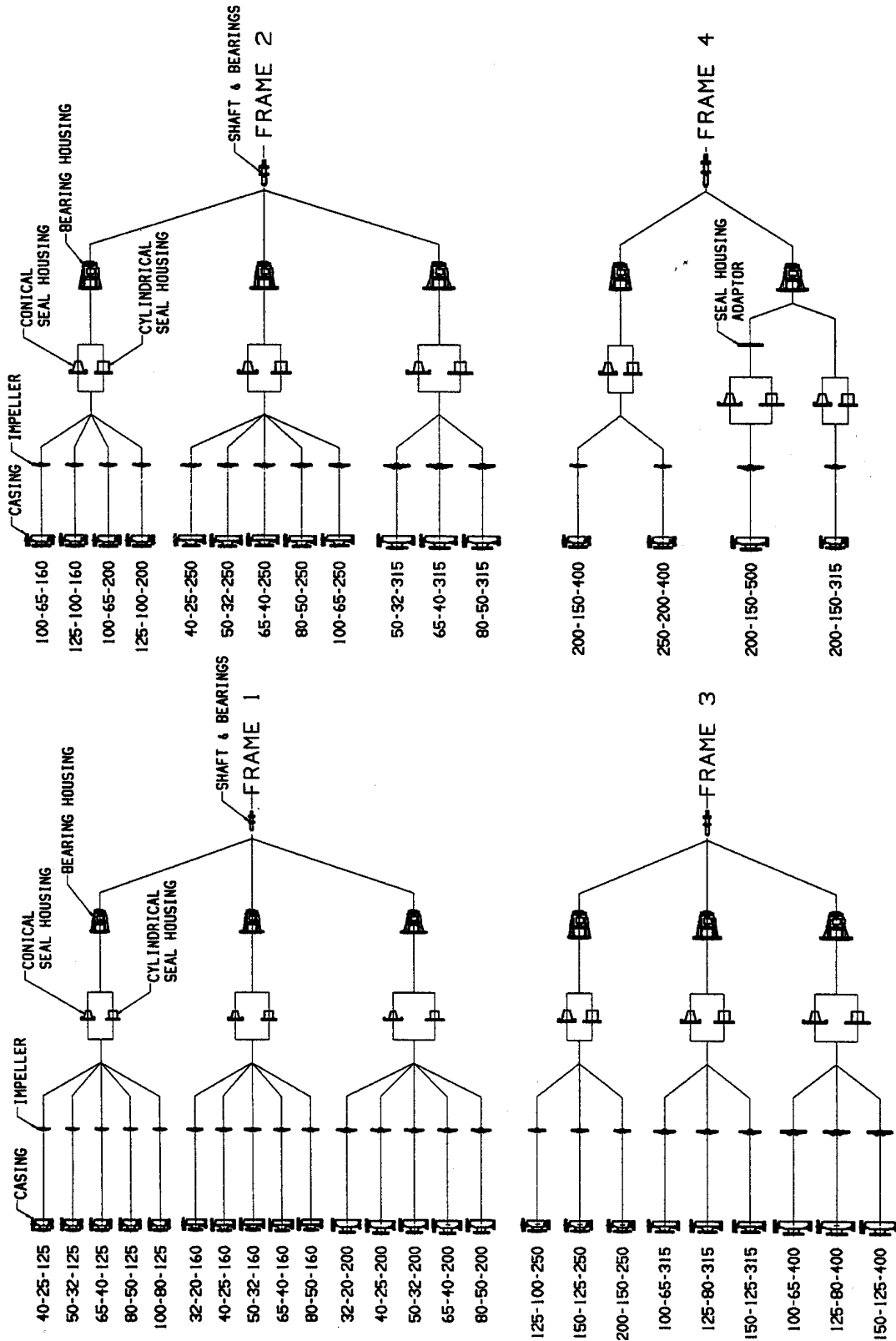



### 8.5.2 CPXP parts interchangeability

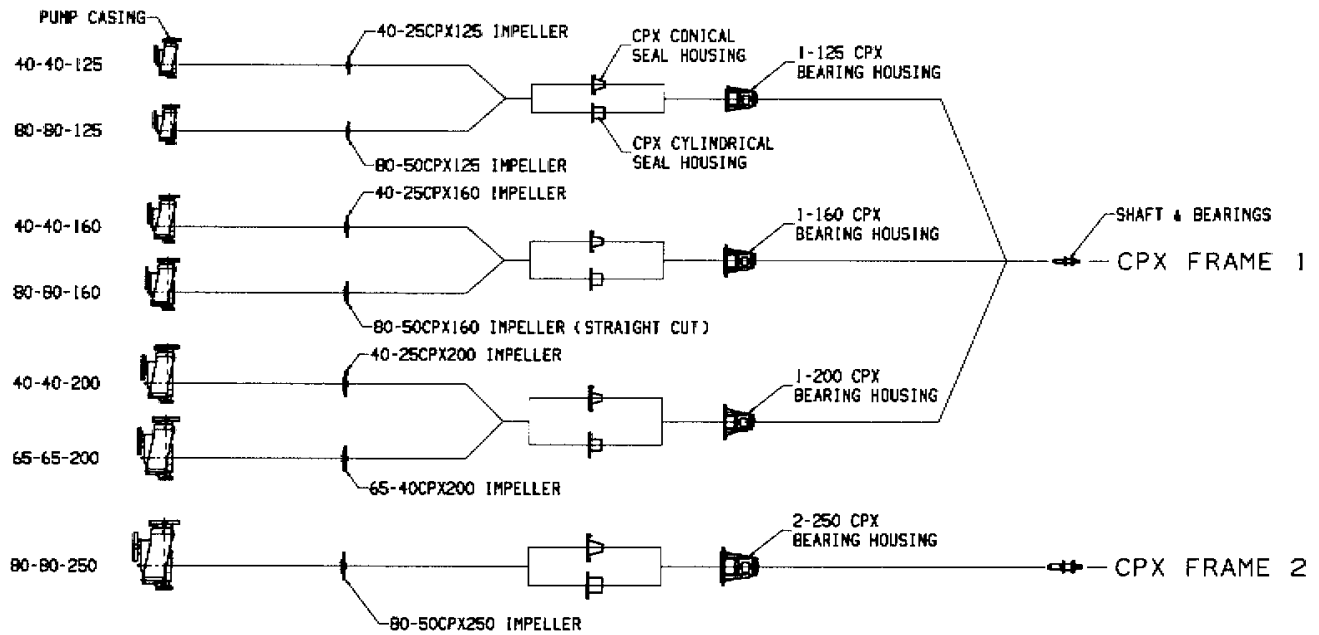

### 8.6 General arrangement drawing

The typical general arrangement drawing and any specific drawings required by the contract will be sent to the Purchaser separately unless the contract specifically calls for these to be included into the User Instructions. If required, copies of other drawings sent separately to the Purchaser should be obtained from the Purchaser and retained with these User Instructions.

## **9 CERTIFICATION**

Certificates determined from the Contract requirements are provided with these Instructions where applicable. Examples are certificates for CE marking, ATEX marking etc. If required, copies of other certificates sent separately to the Purchaser should be obtained from the Purchaser for retention with these User Instructions.

## **10 OTHER RELEVANT DOCUMENTATION AND MANUALS**

### **10.1 Supplementary User Instruction manuals**

Supplementary instruction determined from the contract requirements for inclusion into User Instructions such as for a driver, instrumentation, controller, sub-driver, seals, sealant system, mounting component etc are included under this section. If further copies of these are required they should be obtained from the purchaser for retention with these User Instructions.

Where any pre-printed set of User Instructions are used, and satisfactory quality can be maintained only by avoiding copying these, they are included at the end of these User Instructions such as within a standard clear polymer software protection envelope.

### **10.2 Change notes**

If any changes, agreed with Flowserve Solution Group, are made to the product after its supply, a record of the details should be maintained with these User Instructions.

### **10.3 Additional sources of information**

*Reference 1:*

NPSH for Rotodynamic Pumps: a reference guide, Europump Guide No. 1, Europump & World Pumps, Elsevier Science, United Kingdom, 1999.

*Reference 2:*

Pumping Manual, 9<sup>th</sup> edition, T.C. Dickenson, Elsevier Advanced Technology, United Kingdom, 1995.

*Reference 3:*

Pump Handbook, 2<sup>nd</sup> edition, Igor J. Karassik et al, McGraw-Hill Inc., New York, 1993.

*Reference 4:*

ANSI/HI 1.1-1.5. Centrifugal Pumps - Nomenclature, Definitions, Application and Operation.

*Reference 5:*

ANSI B31.3 - Process Piping.



**Notes:**



**Notes:**

**Your Flowserve factory contact:**

Flowserve Sihi (Spain) S.L.  
Vereda de los Zapateros C.P. 28223  
Pozuelo de Alarcón Madrid  
Spain

Flowserve Sihi (Spain) S.L.  
Avenida de Madrid 67 C.P. 28500  
Arganda del Rey Madrid  
Spain

Telephone +34 (0)91 709 1310  
Fax +34 (0)91 715 9700

**Your local Flowserve representative:**

Flowserve India Controls Pvt.Ltd. – Pump Division  
SF No. 136/3 & 137, Myleripalayam Road,  
Myleripalayam Post,  
Othakkalmandapam, Coimbatore 641032, India

Flowserve Fluid Motion and Control (Suzhou)  
Co.Ltd.  
No. 26, Lisheng Road,  
Suzhou Industrial Park, Suzhou 215021,  
Jiangsu Province, P.R.China

Flowserve GB Limited  
Lowfield Works, Balderton  
Newark, Notts NG24 4BU  
United Kingdom  
Telephone (24 hours) +44 1636 494 600  
Repair & Service Fax +44 1636 494 833

To find your local Flowserve representative please  
use the Sales Support Locator System found at  
[www.flowserve.com](http://www.flowserve.com)

**FLOWSERVE REGIONAL  
SALES OFFICES:**

**USA and Canada**

Flowserve Corporation  
5215 North O'Connor Blvd.,  
Suite 2300  
Irving, Texas 75039-5421, USA  
Telephone +1 972 443 6500  
Fax +1 972 443 6800

**Europe, Middle East, Africa**

Flowserve FSG – Italy  
Worthing S.r.l.  
Via Rossini 90/92  
20033 Desio (Milan), Italy  
Telephone +39 0362 6121  
Fax +39 0362 628 882

**Latin America and Caribbean**

Flowserve Corporation  
6840 Wynnwood Lane  
Houston, Texas 77008, USA  
Telephone +1 713 803 4434  
Fax +1 713 803 4497

**Asia Pacific**

Flowserve Pte. Ltd  
10 Tuas Loop  
Singapore 637345  
Telephone +65 6771 0600  
Fax +65 6862 2329