

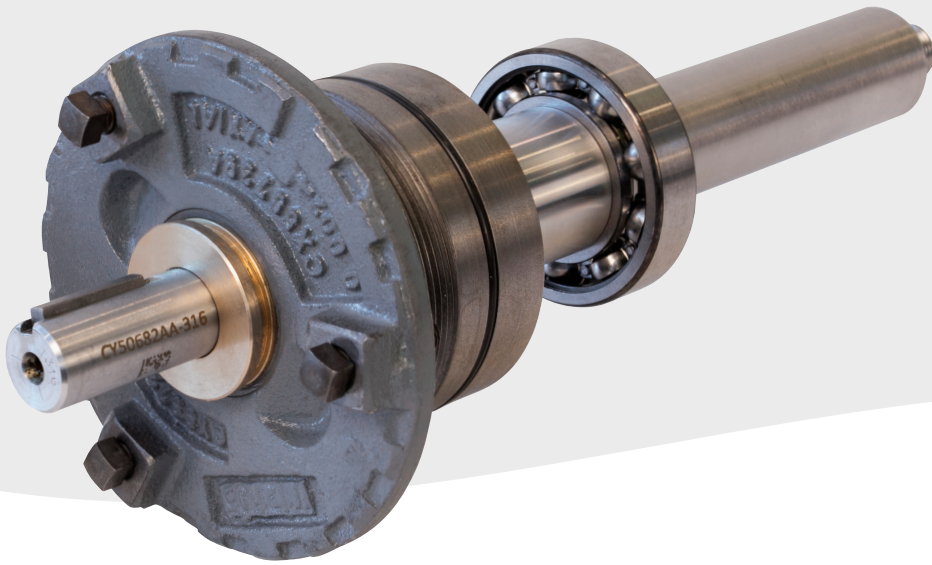

Durco® PRIME **Aftermarket Support for** **ASME (ANSI) Pumps**



Experience In Motion



Pump Pack C
replacement
shaft cartridge

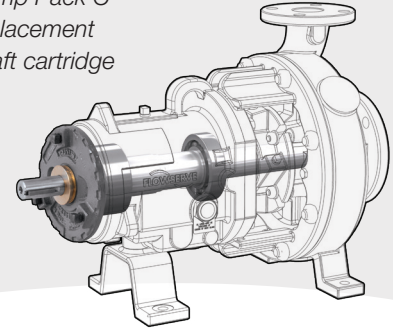

Durco PRIME: The right fit for you and your pump

Durco Mark 3™ chemical process pumps have a well-earned reputation for excellent performance and extended reliability. To keep them running in peak condition, Flowserve offers Durco PRIME, an aftermarket program in North America that provides pump operators with seven levels of service. Pump operators are assured reliable OEM quality parts with convenient maintenance support how and when they want it. Whether the goal is to reduce parts inventory, simplify maintenance activities, standardize equipment or upgrade technology, Durco PRIME can help.



Pump
Pack B
parts kit

Pump maintenance packs

Durco pump maintenance packs are convenient replacement parts kits for routine power end repair.

One box with one part number reduces inventories, simplifies maintenance and ensures pumps are quickly returned to service.

- 1. Pump Pack A** — Routine maintenance couldn't be simpler with Pump Pack A. Includes: gaskets, carrier and adapter O-rings, and isolators (or lip seals). Available for Group 1, 2 and 3 pumps. *Refer to Bulletin PS-100-13 for details.*
- 2. Pump Pack B** — Pump Pack B makes it easy to restore Mark 3 pumps to prime operating condition. Everything is in one box. No return trips to the stockroom for a forgotten or mis-sized part. Contains: gaskets, carrier and adapter O-rings, isolators (or lip seals), bearings, locking hardware, retaining ring, shaft key, sightglass and breather vent. *Refer to Bulletin PS-100-13 for details.*
- 3. Pump Pack C** — Factory-assembled in a clean room, the Pump Pack C shaft cartridge replaces 15 separate parts with just one assembly. It is guaranteed to fit precisely and run true for best-in-class reliability. A variety of materials of construction is available. Includes: shaft, bearings, locking hardware, bearing carrier, carrier O-rings, carrier screws, retaining ring, shaft key and isolators. *Refer to Bulletin PS-100-14 for details.*

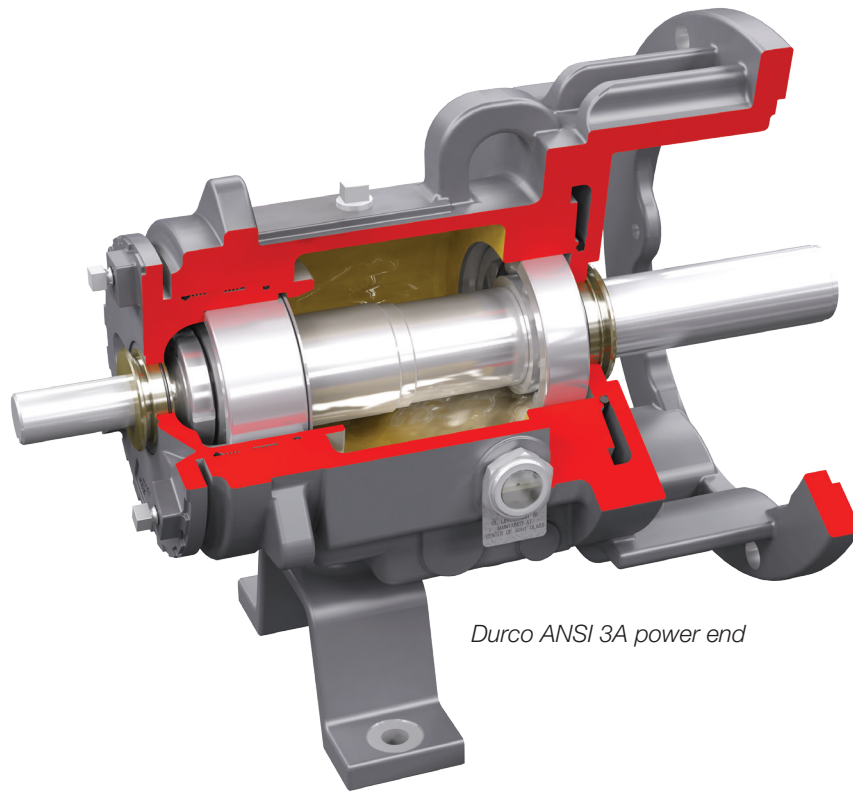

Durco ANSI 3A power end

Power end services

Durco Mark 3A™ and ANSI 3A™ power ends are well-known for their long-term reliability and industry-leading performance. Now enjoy these advantages with the convenience of Durco PRIME.

4. Mark 3A standard power end replacement — Easily replace worn Mark 3 or upgrade older Mark Two pumps with new Mark 3A power ends. Get the reliability and maintenance and performance-enhancing features of the Mark 3A power end with the convenience of plug-and-play maintenance. Refer to *Bulletin PS-10-13* for details about the benefits of the Mark 3A power end.

5. ANSI 3A power end upgrades — Now more ASME (ANSI) pump users can enjoy the performance and reliability benefits of Durco's advanced ANSI 3A power end. Mark 3A power ends can be upgraded to the ANSI 3A. These power ends are so reliable they carry a lifetime warranty¹. Refer to *Bulletin PS-10-13* for details about the benefits of the ANSI 3A power end.

6. Power end exchange — Eliminate out-of-stock situations by exchanging worn power ends with ANSI 3A technology. New or refurbished units are delivered directly to the plant when needed. Whether you use Mark 3A or ANSI 3A power ends, Flowserve power end exchange services are customized to meet each pump operator's specific needs.

¹. Adherence to proper installation, operation and maintenance procedures is necessary for lifetime warranty. Contact your Flowserve representative for detailed terms and conditions.

Condition monitoring

7. RedRaven condition monitoring and IoT solutions —

Durco Mark 3 pumps are compatible with advanced internet of things (IoT) solutions such as RedRaven condition monitoring from Flowserve. Flowserve RedRaven IoT solutions give you the insights and tools you need to monitor, analyze and predict equipment performance — so you can respond to problems quickly and minimize disruptions and downtime.



Ask your Flowserve representative about optional RedRaven IoT monitoring packages or visit flowserve.com/iot to learn more.

Getting started

Contact your local Flowserve sales representative to find out which service fits your needs best and how to get started. To find the nearest Flowserve sales representative or sales office, go to [Flowserve.com](https://flowserve.com).



For more information

about Durco PRIME maintenance packs, email DurcoPrimePacks@flowserve.com.

You may also call +1 800 526 3569 from 8 a.m. to 5 p.m. Eastern Time or

+1 757 679 5992 after hours.

Flowserve Corporation
5215 North O'Connor Blvd.
Suite 700
Irving, Texas 75039-5421 USA
Telephone: +1 937 890 5839

Flowserve Corporation has established industry leadership in the design and manufacture of its products. When properly selected, this Flowserve product is designed to perform its intended function safely during its useful life. However, the purchaser or user of Flowserve products should be aware that Flowserve products might be used in numerous applications under a wide variety of industrial service conditions. Although Flowserve can provide general guidelines, it cannot provide specific data and warnings for all possible applications. The purchaser/user must therefore assume the ultimate responsibility for the proper sizing and selection, installation, operation, and maintenance of Flowserve products. The purchaser/user should read and understand the Installation Instructions included with the product, and train its employees and contractors in the safe use of Flowserve products in connection with the specific application.

While the information and specifications contained in this literature are believed to be accurate, they are supplied for informative purposes only and should not be considered certified or as a guarantee of satisfactory results by reliance thereon. Nothing contained herein is to be construed as a warranty or guarantee, express or implied, regarding any matter with respect to this product. Because Flowserve is continually improving and upgrading its product design, the specifications, dimensions and information contained herein are subject to change without notice. Should any question arise concerning these provisions, the purchaser/user should contact Flowserve Corporation at any one of its worldwide operations or offices.

PUFLY000505-02 (EN/A4) April 2022
(Formerly PS-100-12)

©2022 Flowserve Corporation. All rights reserved. This document contains registered and unregistered trademarks of Flowserve Corporation. Other company, product, or service names may be trademarks or service marks of their respective companies.