

TBR PTFE bellows seal

An outside mounted, nonmetallic PTFE bellows seal has proven performance in highly corrosive applications, eliminating elastomer secondary seal problems such as shaft fretting and shaft packing hang-up.



Features and Benefits

- PTFE bellows provide nearly universal chemical resistance for a wide range of services.
- Non-wetted metal parts eliminate the need for expensive metallurgies.
- The TBR bellows is inherently hydraulically balanced to ensure proper face loading.
- Installs easily on outside of stuffing box.
- Replaceable seal face for low cost repairs.
- No elastomers are required.

Operating Parameters

Pressure	Up to 75 psig (5 bar)
Temperature	160°F (71°C)
Speed	3600 rpm

Materials of Construction

Seal ring	Carbon, silicon carbide and glass-filled PTFE
Insert	Silicon carbide and ceramic
Bellows	PTFE
Collar	316 stainless steel and Alloy C-276

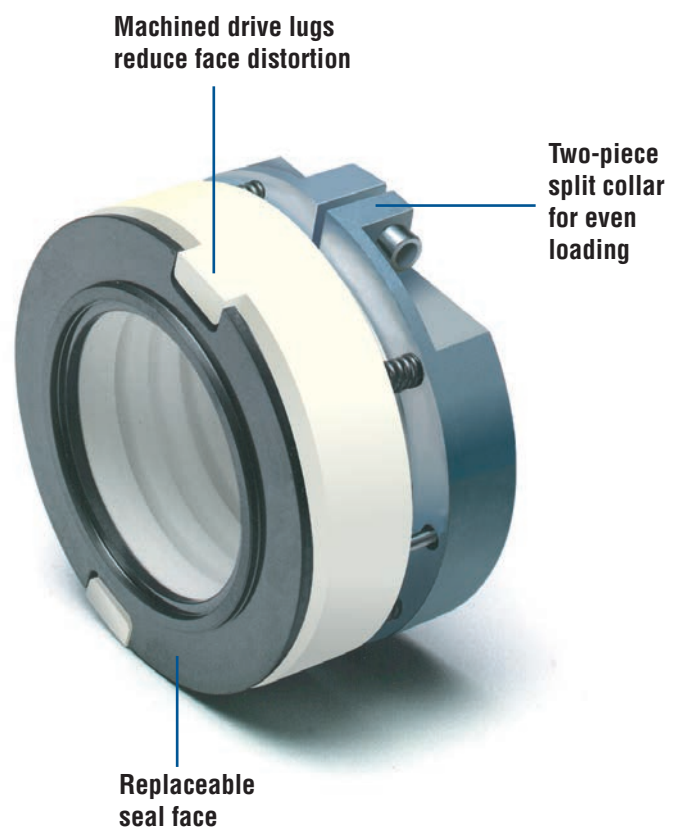

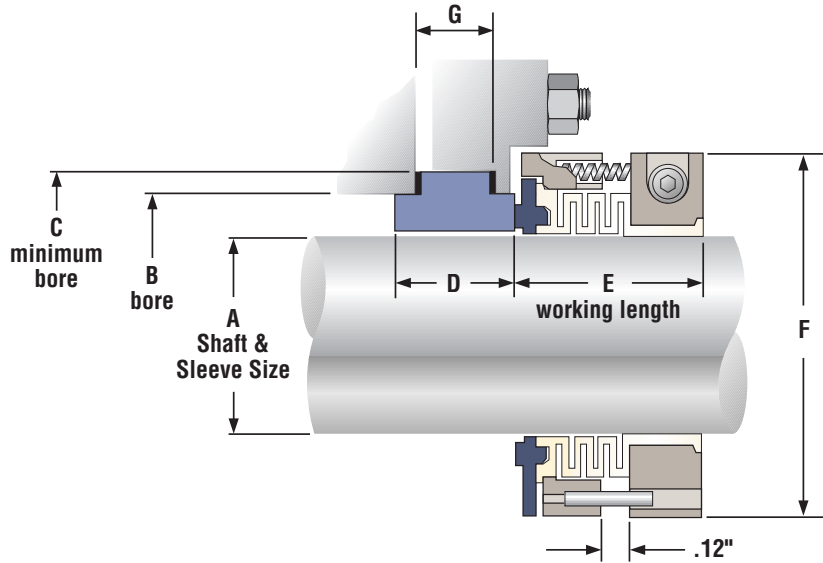

Dimensional Data in inches (millimeters)

A Shaft & Seal Size ±.001" (.025mm)	B ±.005" (.127mm)	C	D	E	F	G
1.000 (25.40)	1.625 (41.28)	2.000 (50.80)	.75 (19.05)	1.12 (28.45)	2.25 (57.15)	.500 (12.70)
1.125 (28.58)	1.750 (44.45)	2.000 (50.80)	.88 (22.35)	1.12 (28.45)	2.38 (60.45)	.625 (15.88)
1.250 (31.75)	1.875 (47.63)	2.250 (57.15)	.88 (22.35)	1.12 (28.45)	2.50 (63.50)	.625 (15.88)
1.375 (34.93)	2.000 (50.80)	2.375 (60.32)	.88 (22.35)	1.12 (28.45)	2.62 (66.55)	.625 (15.88)
1.500 (38.10)	2.125 (53.97)	2.500 (63.50)	.88 (22.35)	1.25 (31.75)	2.75 (69.85)	.625 (15.88)
1.625 (41.28)	2.375 (60.32)	2.750 (69.85)	.88 (22.35)	1.25 (31.75)	2.88 (73.15)	.625 (15.88)
1.750 (44.45)	2.500 (63.50)	2.905 (73.79)	.88 (22.35)	1.50 (38.10)	3.00 (76.20)	.625 (15.88)
1.875 (47.63)	2.625 (66.68)	2.875 (73.02)	.88 (22.35)	1.50 (38.10)	3.12 (79.25)	.625 (15.88)
2.000 (50.80)	2.750 (69.85)	3.125 (79.38)	.88 (22.35)	1.50 (38.10)	3.38 (85.85)	.625 (15.88)
2.125 (53.97)	2.875 (73.02)	3.250 (82.55)	.88 (22.35)	1.50 (38.10)	3.50 (88.90)	.625 (15.88)
2.250 (57.15)	3.000 (76.20)	3.375 (85.73)	.88 (22.35)	1.50 (38.10)	3.62 (91.95)	.625 (15.88)
2.375 (60.32)	3.125 (79.38)	3.500 (88.90)	.88 (22.35)	1.62 (41.15)	3.75 (95.25)	.625 (15.88)
2.500 (63.50)	3.375 (85.73)	3.750 (95.25)	.88 (22.35)	1.62 (41.15)	3.88 (98.55)	.625 (15.88)
2.625 (66.68)	3.625 (92.07)	4.000 (101.60)	.88 (22.35)	1.62 (41.15)	4.00 (101.60)	.625 (15.88)
2.750 (69.85)	3.750 (95.25)	4.125 (104.77)	.88 (22.35)	1.62 (41.15)	4.12 (104.65)	.625 (15.88)
2.875 (73.02)	3.875 (98.43)	4.250 (107.95)	.88 (22.35)	1.62 (41.15)	4.25 (107.95)	.625 (15.88)
3.000 (76.20)	4.000 (101.60)	4.375 (111.13)	.88 (22.35)	1.62 (41.15)	4.38 (111.25)	.625 (15.88)

Note: For sizes and conditions not listed, contact your local Flowserve Representative.

FSD164eng REV 08-06 Printed in USA

To find your local Flowserve representative
and find out more about Flowserve Corporation
visit www.flowserve.com

Flowserve Corporation has established industry leadership in the design and manufacture of its products. When properly selected, this Flowserve product is designed to perform its intended function safely during its useful life. However, the purchaser or user of Flowserve products should be aware that Flowserve products might be used in numerous applications under a wide variety of industrial service conditions. Although Flowserve can provide general guidelines, it cannot provide specific data and warnings for all possible applications. The purchaser/user must therefore assume the ultimate responsibility for the proper sizing and selection, installation, operation, and maintenance of Flowserve products. The purchaser/user should read and understand the Installation Instructions included with the product, and train its employees and contractors in the safe use of Flowserve products in connection with the specific application.

While the information and specifications contained in this literature are believed to be accurate, they are supplied for informative purposes only and should not be considered certified or as a guarantee of satisfactory results by reliance thereon. Nothing contained herein is to be construed as a warranty or guarantee, express or implied, regarding any matter with respect to this product. Because Flowserve is continually improving and upgrading its product design, the specifications, dimensions and information contained herein are subject to change without notice. Should any question arise concerning these provisions, the purchaser/user should contact Flowserve Corporation at any one of its worldwide operations or offices.

© 2006 Flowserve Corporation

USA and Canada

Kalamazoo, Michigan USA
Telephone: 1 269 381 2650
Telefax: 1 269 382 8726

Europe, Middle East, Africa

Roosendaal, The Netherlands
Telephone: 31 165 581400
Telefax: 31 165 554590

Asia Pacific

Singapore
Telephone: 65 6544 6800
Telefax: 65 6214 0541

Latin America

Mexico City
Telephone: 52 55 5567 7170
Telefax: 52 55 5567 4224