



USER INSTRUCTIONS

Durco® Mark 3™ Group 4 High-Capacity Chemical Process Pump

Mark 3 standard single stage, radially split foot mounted pumps

Installation Operation Maintenance

75715555 EN

Original Instructions

 **These instructions must be read prior to installing, operating, and maintaining this equipment.**





Copyright

All rights reserved. No part of these instructions may be reproduced, stored in a retrieval system or transmitted in any form or by any means without prior permission of Flowserve Corporation.

Document Version

Release, Date: 13-SEP-2018

CONTENTS

1	General Information	4
1.1	Scope of manual	4
1.2	Disclaimer	5
1.3	Certification instruction	5
1.4	Units	5
2	Safety Information	6
2.1	Intended use.....	6
2.2	Safety symbols and description.....	6
2.3	General hazard sources.....	8
2.4	Potential explosive areas.....	11
2.5	Responsibility of the operating company	16
2.6	Qualified personnel and targeted group	16
2.7	Industrial health and safety measures.....	16
2.8	Protective equipment	16
3	Product Description	17
3.1	General product description	17
3.2	Design	18
3.3	Scope of delivery	19
3.4	Function description	19
3.5	Connections	19
3.6	Controls.....	35
3.7	Accessories	35
3.8	Tools, equipment, and fixtures	35
4	Packaging, Transportation and Storage	36
4.1	Consignment receipt	36
4.2	Unpacking.....	36
4.3	Packaging.....	37
4.4	Transportation.....	38
4.5	Storage and packing	45
5	Installation	47
5.1	Inspection and preparation	47
5.2	Baseplate mounting	48
5.3	Installation	52
6	Commissioning	64
7	Operation	65
7.1	Start-up	65
7.2	Normal operation.....	65
7.3	Cleaning, disinfecting, and sterilizing	71

7.4	Shut-down	71
8	Maintenance, disassembly, inspection of parts, & assembly	72
8.1	Maintenance procedure.....	72
8.2	Schedule	74
8.3	Special tools.....	75
8.4	Required replacement parts for maintenance	75
8.5	Disassembly.....	76
8.6	Inspection of parts	85
8.7	Power end assembly	97
8.8	Wet end assembly	106
8.9	Post maintenance inspection	117
8.10	Spare parts stocking recommendation	118
9	Troubleshooting Guide	121
10	Decommissioning and Recommissioning	124
10.1	Decommissioning.....	124
10.2	Recommissioning	124
11	Returns and Disposal.....	125
11.1	Returns	125
11.2	Disposal and recycling.....	125
12	Technical Data.....	126
12.1	Equipment dimensions and weights	126
12.2	Nameplate.....	127
12.3	Operating limits	128
12.4	Torque requirements.....	128
12.5	Noise level	128
12.6	Energy rating.....	130
Annex A:	Declaration of Conformity	131
Annex B:	Technical Terms, Acronyms, and Abbreviations	132
Annex C:	Additional Sources of Information	133
Annex D:	Supplementary User Instructions.....	135
NOTES:	136

1 General Information

1.1 Scope of manual



These instructions must be kept close to the product's operating location or directly with the product.



These instructions must be read prior to installing, operating, using, or maintaining the equipment in any region worldwide. The equipment must not be put into service until all of the safe operating conditions noted in the instructions have been met. **Failure to comply with the information provided in the User Instructions is considered to be misuse. Personal injury, product damage, delay in operation, or product failure caused by misuse are not covered by the Flowserve warranty.**

Flowserve products are designed, developed and manufactured with state-of-the-art technologies in modern facilities. The unit is produced with great care and commitment to continuous quality control, utilizing sophisticated quality techniques, and safety requirements.

Flowserve is committed to continuous quality improvement and being at your service for any further information about the product in its installation and operation or about its support products, repair and diagnostic services.

The following user information covers the Flowserve, Durco, Mark 3 Group 4:

English ASME Units - Class 150,

Suction NPS 8" – 16"

Discharge NPS 4" – 16"

Comes with or without Flowserve IPS-Beacon™ equipment

These instructions are intended to familiarize the reader with the product and its permitted use. Operating the product in compliance with these instruction is important to help ensure reliability in service and avoid risks. These instructions may not take into account all local regulations; ensure such regulations are observed by all, including those installing the product. Always coordinate repair activities with operations personnel, and follow all plant safety requirements and applicable safety and health legislation.

Supplementary user instructions determined from the contract requirements for inclusion into User Instructions for buy-out equipment such as driver, instrumentation, controller, sub-driver, seals, seal system, mounting component etc. If required, copies of other information sent separately to the Purchaser should be obtained from the Purchaser and retained with these User Instructions.

The typical general arrangement drawing and any specific drawings required by the contract will be sent to the Purchaser separately unless the contract specifically calls for these to be included into the User Instructions. If required, copies of other drawings sent separately to the Purchaser should be obtained from the Purchaser and retained with these User Instructions.

If any changes, agreed with Flowserve Solution group, are made to the product after it is supplied, a record of the details should be maintained with these User instructions.

1.2 Disclaimer

Information in this User Instruction is believed to be complete and reliable. In spite of all Flowserve's efforts to provide comprehensive information and instructions, sound engineering and safety practices should always be used. Please consult with a qualified engineer.

Flowserve manufactures products to applicable International Quality Management System Standards as certified and audited by external Quality Assurance organizations. Genuine parts and accessories have been designed, tested, and incorporated into the products to help ensure continued product quality and performance in use. As Flowserve cannot test parts and accessories sourced from other vendors the incorrect incorporation of such parts and accessories may adversely affect the performance and safety features of the product. The failure to properly select, install, or use authorized Flowserve parts and accessories is considered to be misuse. Damage or failure caused by misuse is not covered by Flowserve's warranty. In addition, any modification of Flowserve products or removal of original components may impair the safety of these products in use.

1.3 Certification instruction

Certificates defined in the Contract requirements are provided with these instructions where applicable. Examples are certificates for CE marking and ATEX marking etc. If required, copies of other certificates sent separately to the Purchaser should be obtained from the Purchaser for retention with this User Instruction.

1.4 Units

This product was designed with United States customary system (USC) units. However, the primary system of units in this document is the International System of Units (SI). USC units are display in (parenthesize).

2 Safety Information

2.1 Intended use

This product has been selected to meet the specifications of your purchase order. The acknowledgement of these conditions has been sent separately to the Purchaser. A copy should be kept with these instructions.



The product/system must not be operated beyond the parameters specified for the application. If there is any doubt as to the suitability of the product/system for the application intended, contact Flowserve for advice, quoting the serial number.

- Installing, operating, or maintaining the product/system in any way that is not covered in this User Instruction could cause death, serious personal injury, or damage to the equipment. This includes any modification to the product/system or use of the parts not provided by Flowserve.
- Only operate the product/system when it has successfully passed all inspection acceptance criteria
- Do not operate the product/system in a partially assembled condition.
- If the conditions of service on the customer's purchase order change (i.e. pumping fluid, temperature, or duty conditions) it is requested that the user seeks written agreement from Flowserve before start up.
- Observe equipment labels, such as arrows designating the direction of rotation, warning signs, etc., and keep them in a legible condition. Replace any damaged and/or illegible labels immediately.

If the conditions of service on your purchase order are going to be changed (for example liquid pumped, temperature or duty) it is requested that user seeks the written agreement of Flowserve before start up.

2.2 Safety symbols and description

This User Instruction contains specific safety markings where non-observance of an instruction would cause a hazard. The specific safety markings can be found in Table 1: *Definition of safety symbols and markings*, and Table 2: *Additional symbols*.

Table 1: Definition of Safety Symbols & Markings

Symbol	Description
	DANGER This symbol indicates a hazardous situation which, if not avoided, will result in death or serious injury
	WARNING This symbol indicates a hazardous situation which, if not avoided, could result in death or serious injury
	CAUTION This symbol indicates a hazardous situation which, if not avoided, could result in minor or moderate injury
	SAFETY INSTRUCTIONS This symbol indicates specific safety-related instruction or procedures
	NOTICE This symbol is used to address practices not related to physical injury
	This is the safety alert symbol. It is used to alert you to potential physical injury hazards. Obey all safety messages that follow this symbol to avoid possible injury or death.

Table 2: Additional Symbols

Symbol	Description
	ELECTRICAL HAZARD This symbol indicates electrical safety instructions where non-compliance would affect personal safety and could result in loss of life
	TOXIC HAZARD This symbol indicates "hazardous substances and toxic fluid" safety instructions where non-compliance would affect personal safety and would damage the equipment or property
	ATEX EXPLOSION PROTECTION This symbol indicates explosive atmosphere marking according to ATEX. It is used in safety instructions where non-compliance in the hazardous area would cause the risk of an explosion
	DO NOT USE DRY CLOTH This symbol is used in safety instructions to remind not to rub non-metallic surfaces with a dry cloth; ensure the cloth is damp. It is used in safety instructions where non-compliance in the hazardous area would cause risk of an explosion.

2.3 General hazard sources

This is a summary of conditions and actions to help prevent injury to personnel and damage to the environment and to equipment. For products used in potentially explosive atmospheres section 2.4 also applies.

2.3.1 Mechanical hazards

Lifting limits and guidelines

The load values mentioned in this section are Flowserve recommendations only. All lifting must be done in compliance with site safety protocol, local regulations, and related industry standards.



Many precision parts have sharp corners which require appropriate personal protective equipment during handling. Prior to any attempt to lift an item, personnel must first determine the approximate weight and stability of the load.

- Large, unstable, or awkward loads should always be handled with the assistance of additional personnel or appropriate mechanical means.
- Loads in excess of 23 kg (50 lb.) should only be lifted by appropriate mechanical means and in accordance with current local legislation or with the assistance of additional personnel.
- Lifting items less than 23 kg (50 lb.) may be prohibited without assistance if the lift is repetitive and/or awkward (i.e., away from the body, above the shoulders or below the knees) thus placing excessive stress on the personnel.
- Repetitive lifting of any kind should be evaluated as part of a documented end-user safety program.

See section 4.4, Transportation for proper lifting instructions.

2.3.2 Electrical hazards



NEVER DO MAINTENANCE WORK WHEN THE UNIT IS CONNECTED TO POWER (Lock out)

2.3.3 Hazardous Liquids



When the pump is handling hazardous liquids, care must be taken to avoid exposure to the liquid by appropriate siting of the pump by limiting personnel access and by operator training. If the liquid is flammable and/or explosive, strict safety procedures must be applied.

⚠ CAUTION

GLAND PACKING MUST NOT BE USED WHEN PUMPING HAZARDOUS LIQUIDS

⚠ CAUTION

PREVENT EXCESSIVE EXTERNAL PIPE LOAD

Do not use pump as a support for piping. Do not mount piping expansion joints, unless allowed by Flowserve in writing, so that their force, due to internal pressure, acts on the pump flange. When applied on a pressure line, tie rods limiting the elongation of the joint and take the axial thrust created by the internal pressure must be used.



⚠ CAUTION

NEVER RUN THE PUMP DRY OR WITHOUT PROPER PRIME (Casing flooded)



⚠ CAUTION

NEVER OPERATE THE PUMP WITH THE DISCHARGE VALVE CLOSED. Unless otherwise instructed at a specific point in the User Instructions. See section 6, *Commissioning*, & Section 7, *Operation*



⚠ CAUTION

NEVER OPERATE THE PUMP WITH SUCTION VALVE CLOSED. It should be fully opened when the pump is running



⚠ CAUTION

NEVER OPERATE THE PUMP AT ZERO FLOW OR FOR EXTENDED PERIODS BELOW THE MINIMUM CONTINUOUS FLOW



⚠ CAUTION

DO NOT RUN THE PUMP AT ABNORMALLY HIGH OR LOW FLOW RATES
Operating at a flow rate higher than normal or at a flow rate with no back pressure on the pump may overload the motor and cause cavitation. Low flow rates may cause a reduction in pump/bearing life, overheating of the pump, instability and cavitation/vibration



⚠ CAUTION

ENSURE CORRECT LUBRICATION
See section 5.3.2, *Pump lubricants*

⚠ CAUTION NEVER EXCEED THE MAXIMUM DESIGN PRESSURE (MDP) AT THE TEMPERATURE SHOWN ON THE PUMP NAMEPLATE

See section 7, for pressure versus temperature ratings based on the material of construction

⚠ CAUTION THE PUMP SHAFT MUST TURN CLOCKWISE WHEN VIEWED FROM THE MOTOR END

It is absolutely essential that the rotation of the motor be checked before installation of the coupling spacer and starting the pump. Incorrect rotation of the pump for even a short period can unscrew the impeller nut, which can cause significant damage.

2.3.4 Additional hazards

⚠ GUARDS MUST NOT BE REMOVED WHILE THE PUMP IS OPERATIONAL

⚠ NEVER OPERATE THE PUMP WITHOUT THE COUPLING GUARD AND ALL OTHER SAFETY DEVICES CORRECTLY INSTALLED

⚠ DRAIN THE PUMP AND ISOLATE PIPEWORK BEFORE DISMANTLING THE PUMP

The appropriate safety precautions should be taken where the pumped liquids are hazardous.

⚠ NEVER APPLY HEAT TO REMOVE IMPELLER

Trapped lubricants or vapor could cause an explosion.

⚠ FLUROELASTOMERS (When fitted)

When a pump has experienced temperatures over 250 °C (482 °F), partial decomposition of fluoroelastomers (example: Viton®, ASTM D1418 1629 - FKM) will occur. In this condition these are extremely dangerous and skin contact must be avoided.

⚠ THERMAL SHOCK

Rapid changes in the temperature of the liquid within the pump can cause thermal shock, which can result in damage or breakage of components and should be avoided.



HOT & COLD PARTS

If hot or freezing components or auxiliary heating equipment can present a danger to operators and persons entering the immediate area, action must be taken to avoid accidental contact (such as shielding). If complete protection is not possible, the machine access must be limited to maintenance staff only with clear visual warnings and indicators to those entering the immediate area. Note: bearing housings must not be insulated and drive motors and bearings may be hot.

If the temperature is greater than 80 °C (175 °F) or below -5 °C (23 °F) in a restricted zone, or exceeds local regulations, action as above shall be taken.

2.4 Potential explosive areas



Measures are required to:

- Avoid excess temperature
- Prevent build-up of explosive mixtures
- Prevent the generation of sparks
- Prevent leakages
- Maintain the pump to avoid hazard

All instructions for equipment installed in potentially explosive atmospheres must be followed to help ensure explosion protection. For ATEX, both electrical and non-electrical equipment must meet the requirements of the European Explosion Protection Directive 2014/34/EU. Always observe the regional legal Ex requirements, e.g. Ex electrical items outside the EU may be required certified to other than ATEX e.g. IECEx, UL.

2.4.1 Scope of compliance



Use equipment only in the zone for which it is appropriate. Always check that all equipment is suitably rated and/or certified for the classification of the specific atmosphere in which they are to be installed.

Where Flowserve has supplied only the bare shaft pump, the Ex rating applies only to the pump. The party responsible for assembling the ATEX pump set shall select the coupling, driver and any additional equipment, with the necessary CE Certificate/Declaration of Conformity establishing it is suitable for the area in which it is to be installed.

The output from a variable frequency drive (VFD) can cause additional heating affects in the motor. On pump installations controlled by a VFD, the ATEX Certification for the motor must state that it covers the situation where electrical supply is form the VFD. This particular requirement still applies even if the VFD is in a safe area.

2.4.2 Marking

It is a legal requirement that machinery and equipment put into service within certain regions of the world shall conform with the applicable CE Marking Directives covering Machinery and, where applicable, Low Voltage Equipment, Electromagnetic Compatibility (EMC), Pressure Equipment Directive (PED) and Equipment for Potentially Explosive Atmospheres (ATEX).

Where applicable, the Directive and any additional Approvals, cover important safety aspects relating to machinery and equipment and the satisfactory provision of technical documents and safety instructions. Where applicable this document incorporates information relevant to these Directives and Approvals.

To confirm the Approvals applying and if the product is CE marked, checked the serial number plate markings and the Certification. (See section 1.3, *Certification instruction*)

An example of ATEX equipment marking is shown below. The actual classification of pump will be engraved on the nameplate.

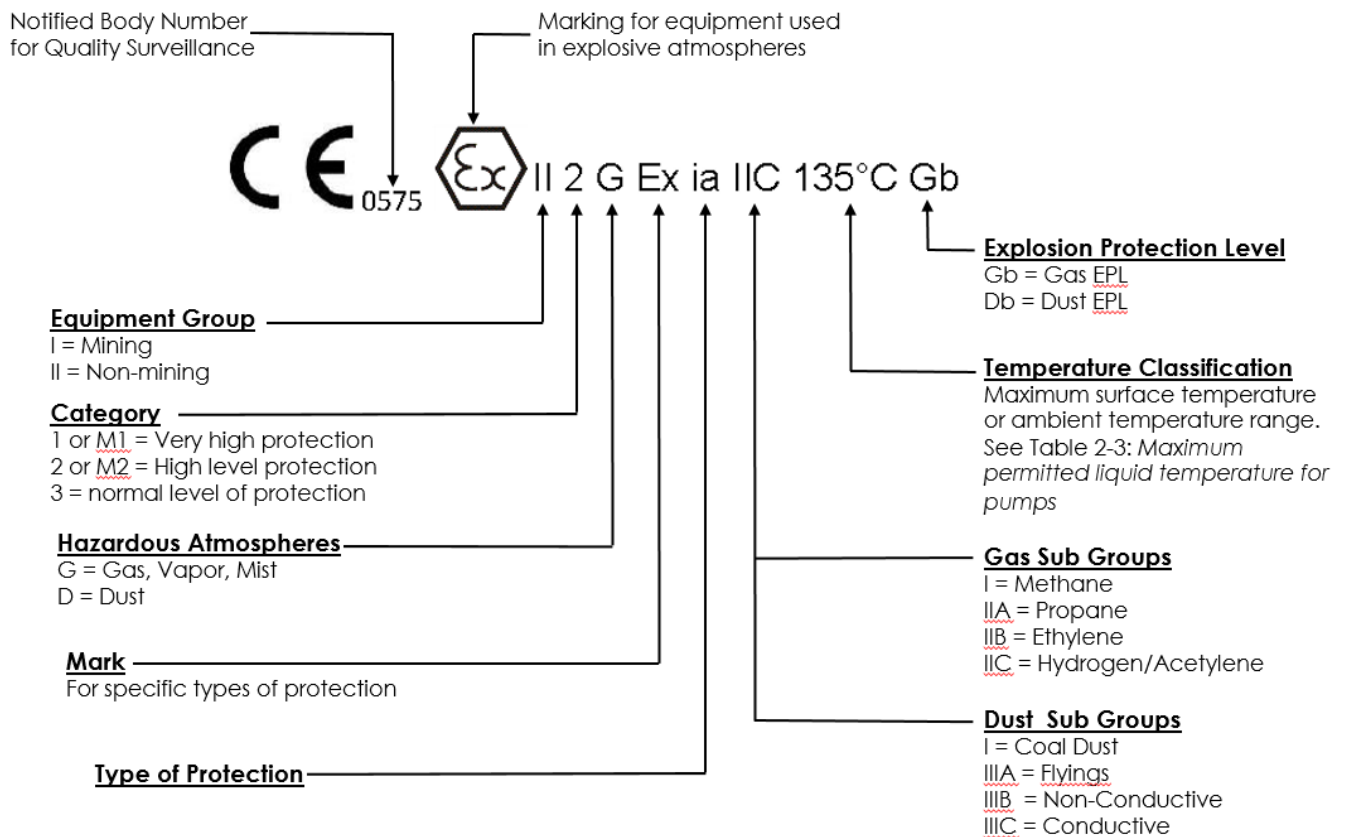

2.4.3 Avoiding excessive surface temperatures



ENSURE THE EQUIPMENT TEMPERATURE CLASS IS SUITABLE FOR THE HAZARD ZONE

Pump liquid temperature

Pumps have a temperature class as stated in the ATEX Ex rating on the nameplate. These are based on a maximum ambient temperature of 40 °C (104 °F); refer to Flowserve for higher ambient temperatures.

The surface temperature on the pump is influenced by the temperature of the liquid handled. The maximum permissible liquid temperature depends on the temperature class and must not exceed the values in the table applicable below.

Table 3: Maximum Permitted Temperature

Temperature class to En 13463-1	Maximum surface temperature permitted	Temperature limit of liquid handled
T6	85 °C (185 °F)	Consult Flowserve *
T5	100 °C (212 °F)	Consult Flowserve *
T4	135 °C (275 °F)	115 °C (239 °F) *
T3	200 °C (392 °F)	180 °C (356 °F) *

*The table only takes the ATEX temperature class into consideration. Pump design or material, as well as component design or material, may further limit the maximum working temperature of the liquid.

The temperature-rise at the seals/bearings and due to the minimum permitted flow rate is taken into account in the temperatures stated.

The operator is responsible to ensure the specified maximum liquid temperature is not exceeded.

Temperature classification “Tx” is used when the liquid temperature varies and when the pump is required to be used in differently classified potentially explosive atmospheres. In this case, the user is responsible for ensuring that the pump surface temperature does not exceed that permitted in its actual installed location.

Do not attempt to check the direction of rotation with coupling element/pins fitted due to risk of severe contact between rotating and stationary components.

Avoid mechanical, hydraulic or electrical overload by using motor overload trips, temperature monitor or a power monitor and perform routine vibration monitoring.

In dirty or dusty environments, make regular checks and remove dirt from areas around close clearances, bearing housings and motors.

Where there is any risk of the pump being run against a closed valve generating high liquid and casing external surface temperature, fit an external surface temperature protection device.

Where the system operation does not ensure control of priming, as defined in these User Instructions, and the maximum permitted surface temperature of the T Class could be exceeded, install an external surface temperature protection device.

2.4.4 Preventing the buildup of explosive mixtures



ENSURE THE PUMP IS PROPERLY FILLED AND VENTED AND DOES NOT RUN DRY

Ensure that the pump and relevant suction and discharge piping system is totally filled with liquid at all times during the pumps operation so that an explosive atmosphere is prevented.

In addition, it is essential to make sure that seal chamber, auxiliary shaft seal systems and any heating and cooling systems are properly filled.

If the operation of the system cannot avoid this condition, fit an appropriate dry run protection device (for example liquid detection or a power monitor).

To avoid potential hazards from fugitive emissions of vapor or gas to atmosphere, the surrounding area must be well ventilated.

2.4.5 Preventing sparks



To prevent a potential hazard from mechanical contact, the coupling guard must be non-sparking for Category 2.

To avoid the potential hazard from random induced current generating a spark, the baseplate must be properly grounded.



Avoid electrostatic charge. Do not rub non-metallic surfaces with a dry cloth; ensure the cloth is damp.

For ATEX the coupling must be selected to comply with 2014/34/EU. Correct coupling alignment must be maintained.

Additional requirements for metallic pumps on non-metallic baseplates

When metallic components are fitted on a non-metallic baseplate they must be individually earthed.

2.4.6 Preventing leakage



The pump must only be used to handle liquids for which it has been approved to have the correct corrosion resistance.

Avoid entrapment of liquid in the pump and associated piping due to closing of suction and discharge valves, which could cause dangerous excessive pressures to occur if there is heat input to the liquid. This can occur if the pump is stationary or running.

Bursting of liquid containing parts due to freezing must be avoided by draining or protecting the pump and auxiliary systems.

Where there is the potential hazard of a loss of a seal barrier fluid or external flush, the fluid must be monitored.

If leakage of liquid to atmosphere can result in a hazard, install a liquid detection device.

2.4.7 Maintenance to avoid the hazard



CORRECT MAINTENANCE IS REQUIRED TO AVOID POTENTIAL HAZARDS WHICH GIVE A RISK OF EXPLOSION

The responsibility for compliance with maintenance instructions is with the plant operator.

To avoid potential explosion hazards during maintenance, the tools, cleaning and painting materials used must not give rise to sparking or adversely affect the ambient conditions. Where there is a risk from such tools or materials, maintenance must be conducted in a safe area.

It is recommended that a maintenance plan and schedule is adopted. (See section 8, *Maintenance*)

2.5 Responsibility of the operating company

To ensure personnel safety the operating company must do the following:

- Complete a risk assessment of the site where the product/system will be in operation, by observing the working conditions
- Create site specific work instructions for the operation of the product
- Ensure that the personnel have read and understand all applicable instructions
- Provide regular training to the necessary personnel in regular intervals
- Provide the required personal protective equipment

2.6 Qualified personnel and targeted group

All personnel involved in the operation, installation, inspection and maintenance of the unit must be qualified to carry out the work involved. If the personnel in question does not already possess the necessary knowledge and skill, appropriate training and instruction must be provided. If required, the operator may commission the manufacturer / supplier to provide applicable training.

Always co-ordinate repair activities with operation and health and safety personnel, and follow all plant safety requirements and applicable safety and health laws and regulations.

2.7 Industrial health and safety measures

Follow industry safety standards including the use of appropriate equipment in required areas.

2.8 Protective equipment

Necessary protective equipment including personal protective equipment shall adhere to facility standards.

3 Product Description

3.1 General product description

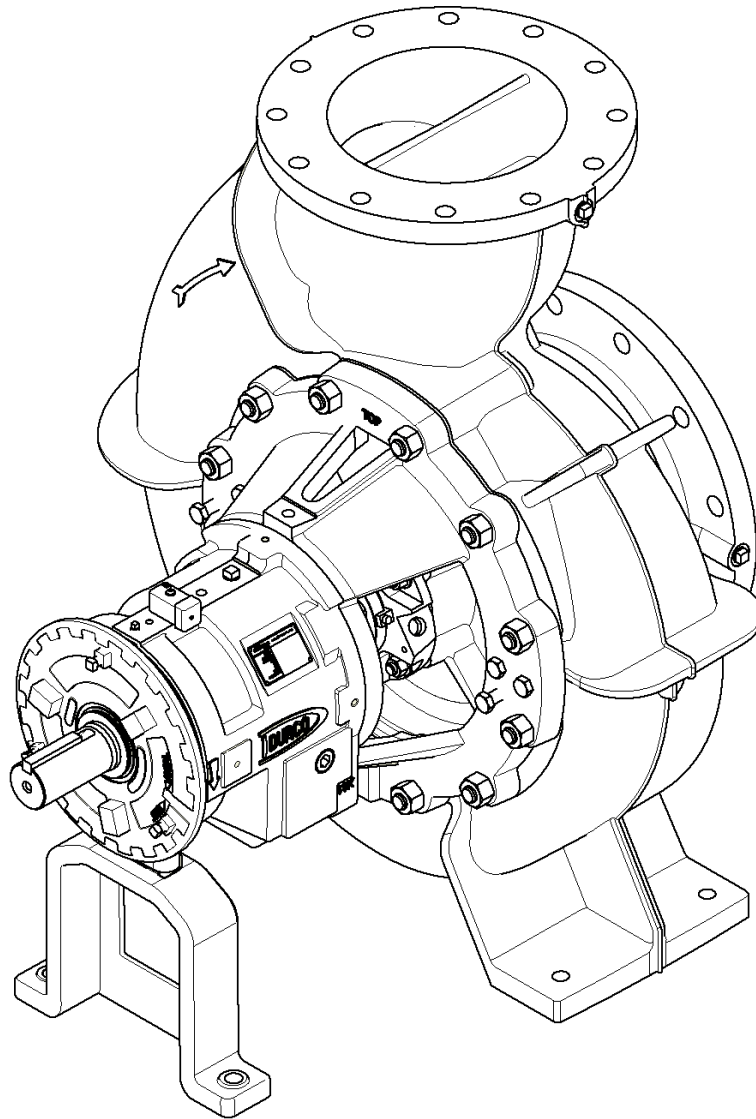

Figure 1: Isometric view of the Mark 3 Group 4

The Flowserve Durco Mark 3 Group 4 product line, is a single stage centrifugal, flexibly coupled, horizontal, foot mounted, end suction, center-line discharge, back pullout pump designed to ASME B73.1 Specification for Horizontal End Suction Centrifugal Pump for Chemical Processing functional requirements.

3.2 Design

3.2.1 Pump Casing

The casing design permits removal of the back pullout assembly from the casing without disturbing the suction and discharge connections. Tapped holes for jackscrews are provided in the adapter to facilitate removal of the back pullout assembly. The design also avoids disturbing the motor, with use of a spacer coupling with sufficient DBSE (Distance Between Shaft Ends).

3.2.2 Impeller

Depending on the configuration, the impeller is either a reverse vane or semi-open design. The attachment is keyed and is protected so not to be wetted by the pumped fluid.

3.2.3 Shaft/sleeve

Solid and sleeved shafts are available, supported on bearings, and keyed drive end. Solid and sleeved shafts are designed to limit dynamic shaft deflection at the impeller centerline to not exceed 0.13 mm (0.005in.) within the allowable operating region as specified in ASME B73.1.

3.2.4 Pump bearings & lubrication

Anti-friction bearings are fitted as standard and may be either oil bath, oil mist or grease lubricated. Bearings are sized in accordance with ANSI/ABMA-9, ANSI/ABMA-11, and ISO 281. The minimum L10 bearing life is 17,500 hr in the allowable operating region.

3.2.5 Bearing Housing

The bearing housing is designed to incorporate four types of lubrication options. The options are ASME B73 Power End (APE4), Oiler Power End (OPE4), Re-greaseable Power End (RPE4) and Oil Mist Power End (MPE4). For details on each configuration and lubricants needed see section 5.3.2, *Pump lubricants*.

3.2.6 Seal Chamber (cover)

The seal chamber has a spigot (rabbet) fit between the pump casing and bearing housing adapter for optimum concentricity. The seal chamber can be a cylindrical or a self-venting tapered design with radial flow modifiers, which eliminates fitting the pump with auxiliary seal piping in many services. A packing box may be fitted as an option.

3.2.7 Shaft Seal

The mechanical seal(s), attached to the pump shaft, prevents the pumped liquid from entering the environment. When fitted with optional shaft packing, pump liquid will exist the pump during normal operation.

3.2.8 Driver

The driver is normally an electric motor. Different drive configurations may be fitted such as internal combustion engines, steam turbines, hydraulic turbines, driven via couplings, belts, gearboxes, drive shafts etc.

3.2.9 Accessories

Accessories may be fitted when specified by the customer. The operation and maintenance of these may not be covered in this document.

3.3 Scope of delivery

The exact scope of the delivery is stated in the order documentation.

3.4 Function description

The Flowserve Mark 3 Group 4 is single-stage centrifugal pump. Mark 3 Group 4 pumps are categorized as a kinetic-energy pump which uses centrifugal force to push the liquid outward from the eye of the impeller where it enters the casing. Differential head can be increased by increasing impeller rotation speed or increasing impeller diameter. The impeller and fluid being pumped are isolated from outside contaminants by packing or mechanical seals. Radial and thrust bearings restrict the movement of the shaft and reduce the friction of rotation. The Mark 3 Group 4 design is widely accepted and has proven to be highly reliable in many applications.

For performance parameters see section 2.1, Intended use. Where performance data has been supplied separately to the purchaser these should be obtained and retained with these User Instructions.

3.5 Connections

3.5.1 Electrical connections



Electrical connections must be made by a qualified Electrician in accordance with relevant local, national and international regulations.



It is important to be aware of the EUROPEAN DIRECTIVE on potentially explosive areas where compliance with IEC 60079-14 is an additional requirement for making electrical connections.



It is important to be aware of the EUROPEAN DIRECTIVE on electromagnetic compatibility when wiring up and installing equipment on site. Attention must be paid to ensure that the techniques used during wiring/installation do not increase electromagnetic emissions or decrease the electromagnetic immunity of the equipment, wiring or any connected devices. If in any doubt, contact Flowserve for advice.



The motor must be wired up in accordance with the motor manufacturer's instructions (normally supplied within the terminal box) including any temperature, earth leakage, current and other protective devices as appropriate. The identification nameplate should be checked to ensure the power supply is appropriate.



A device to provide emergency stopping must be fitted. If not supplied pre-wired to the pump unit, the controller/starter electrical details will also be supplied within the controller/starter. For electrical details on pump sets with controllers see the separate wiring diagram.

CAUTION

See section 8, Maintenance, for direction of rotation before connecting the motor to the electrical supply.

3.5.2 Suction & discharge piping connections

CAUTION

Protective covers are fitted to both the suction and discharge flanges of the casing and must be removed prior to connecting the pump to any pipes.

All piping must be independently supported, accurately aligned and preferably connected to the pump by a short length of flexible piping. The pump should not have to support the dead weight of the pipe, its contents or compensate for misalignment. It should be possible to install suction and discharge bolts through mating flanges without pulling or prying either of the flanges. All piping must be tight. Pumps may air-bind if air is allowed to leak into the piping. If the pump flange(s) have tapped holes, select flange fasteners with thread engagement at least equal to the fasteners diameter but that do not bottom out in the tapped holes before the joint is tight.

3.5.2.1 Suction Piping

To avoid NPSH and suction problems, suction piping must be at least as large as the pump suction connection. Never use pipe or fittings on the suction that are smaller in diameter than the pump suction size. Figure 2 illustrates the ideal piping configuration with a minimum of 10 pipe diameters between the source and the pump suction. Refer to ANSI/HI 9.6.6-2016 Rotodynamic Pump for Pump Piping for minimum required straight pipe length. When multiple fittings are adjacent, the fitting with the longest minimum length requirement will govern the minimum length of the pipe attached to the pump suction.

Where no potential for air or vapor accumulation exists, a concentric reducer is recommended. When the potential for air or vapor accumulation exists, an eccentric convergent reducer is recommended. Where piping approaches from below, the flat side shall be located on top, as shown in Figure 3, with a maximum of one pipe size reduction. Mount eccentric reducers with the flat side down, when the inlet approaches from above. Horizontally mounted concentric reducers should not be used if there is any possibility of entrained air in the process fluid. Vertically mounted concentric reducers are acceptable.

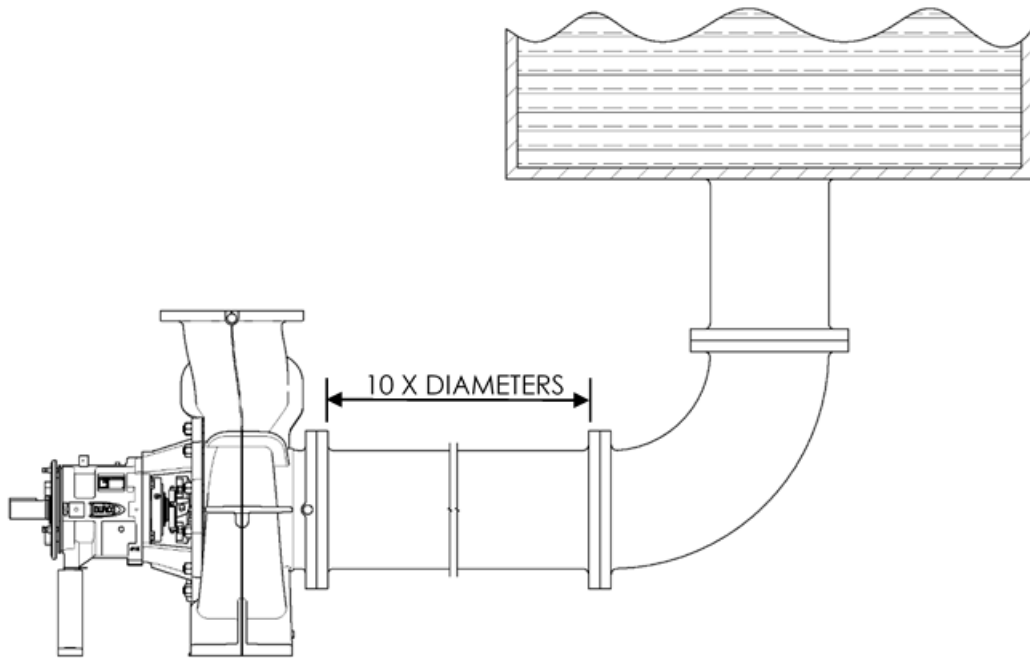

Figure 2: Minimum Piping Configuration

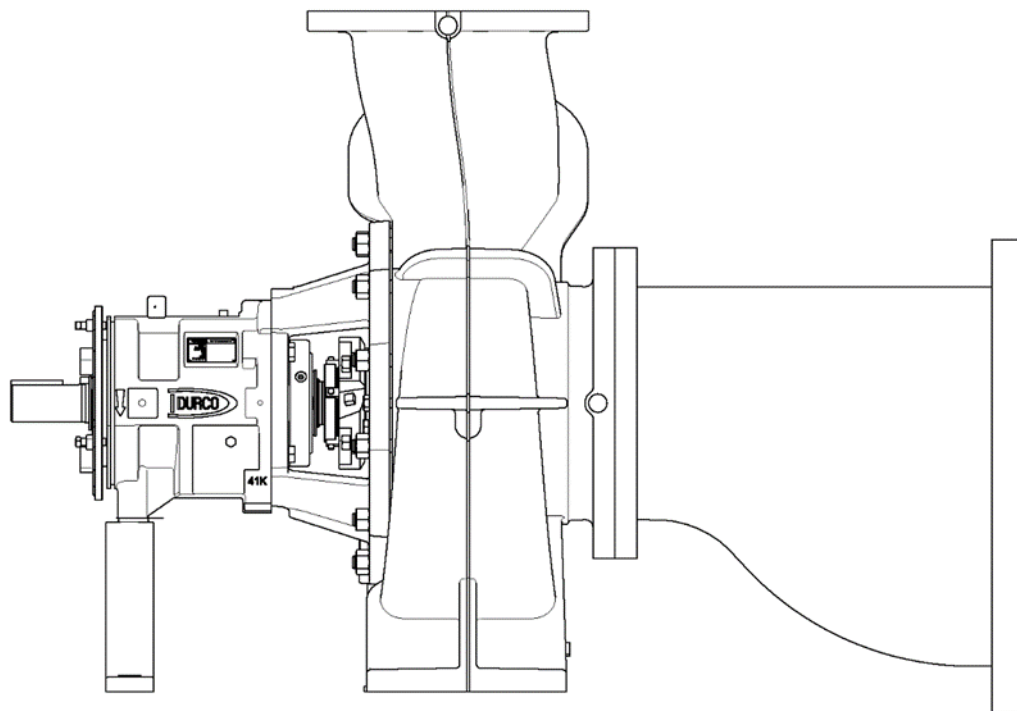

Figure 3: Suction Piping with Eccentric Reducer

Start-up strainers must be removed shortly before final start-up. When the pump is installed below the source of supply, a valve should be installed in the suction line to isolate the pump and permit pump inspection and maintenance. However, never place a valve directly on the suction nozzle of the pump.

A cruciform flow conditioner, as shown in Figure 4, is recommended. Cruciform suction piping is designed as a flow conditioner which reduces swirl, pulsation, noise, and reduces flow profile distortion. The cruciform should extend (2) pipe diameters in to the suction pipe. Minimum length of suction pipe before the cruciform is as specified in ANSI/HI 9.6.6 for length of pipe prior to the pump inlet. See Annex C for addition source recommendation on suction piping.

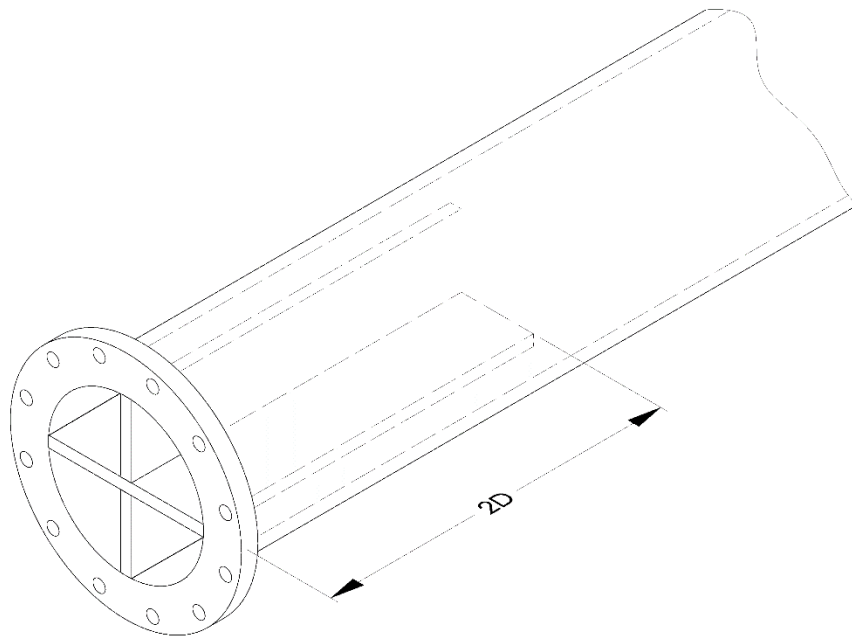

Figure 4: Suction Cruciform

Refer to Section 7.2.6 for performance and operating limits.

3.5.2.2 Discharge piping

Install a valve in the discharge line. This valve is required for regulating flow and/or to isolate the pump for inspection and maintenance. The maximum recommended velocity in the discharge piping is 4.5 m/s (15 ft/s). The straight length of pipe at the discharge nozzle is not subject to this velocity limitation.

An elbow should not be connected directly to the pump discharge. Flow distribution in the discharge nozzle will be affected, reducing pump performance, and having possible other negative effects. This can result in increased noise, vibration, increased nozzle loads.

CAUTION When Fluid velocity in the pipe is high, for example, 3 m/s (10 ft/sec) or higher, a rapidly closing discharge valve can cause a damaging pressure surge, or water hammer. A dampening arrangement should be provided in the piping. Refer to ANSI/HI 9.6.6-Appendix B-Water-2016 Hammer for further information.

3.5.2.3 Gage connections

The pump should be optionally configured with discharge and suction gage connection, TAP II and TAP III, if pump hydraulic performance is to be monitored. Fittings located between the pump and any gage connection should be avoided, as changes in fluid velocity and flow distribution will cause significant errors in observed pressure. Observations taken in the field do not constitute certified results.

3.5.2.4 Allowable nozzle load

In this section, F represents force, M represents moment. Combinations of subscripts are used to define direction, type, and location of the load. Definitions of the subscripts:

1. X, Y, Z: Directions of the load
2. S: Suction flange
3. D: Discharge flange
4. A: Applied load
5. R: Resultant load
6. adj: Adjusted load
7. xS: Horizontal distance from the face of the suction flange to the pump discharge centerline
8. zD: Vertical distance from the face of the discharge flange to the pump suction centerline
9. C: Pump Center

The Flowserve Durco Mark 3 Group 4 pumps are designed with reference to the allowable nozzle loads specified by API 610. The calculation approach is developed based on API 610 with reference to ANSI/HI 9.6.2. The following steps describe how to calculate the allowable loads for each pump and how to determine if the applied loads are acceptable.

1. Determine the appropriate casing “Material Group No.” in Section 7.2.7 Table 17: *Alloy Cross-Reference*.
2. Find the “Casing material correction factor” in Table 4: *Casing Material Correction Factor* based upon the “Material Group No.” and operating temperature. Linear interpolation may be used to determine the correction factor for a specific temperature.
3. Find the “Baseplate correction factor” in Table 5: *Baseplate Correction Factor*. Note that the correction factor depends upon how the baseplate is to be installed.
4. Locate the pump size being evaluated in Table 7: *Nozzle Loading*, and record the allowable load component values.
5. Multiply each load rating found in Table 7: *Nozzle Loading* by the casing material correction factors to get the “adjusted loads” F_{XS_adj} , F_{YS_adj} , F_{ZS_adj} , M_{XS_adj} , M_{YS_adj} , M_{ZS_adj} , F_{XD_adj} , F_{YD_adj} , F_{ZD_adj} , M_{XD_adj} , M_{YD_adj} , M_{ZD_adj} .
6. Record the applied loads at the casing flanges according to the coordinate system found in Figure 5. The 12 forces and moments possible are F_{XSA} , F_{YSA} , F_{ZSA} , M_{XSA} , M_{YSA} , M_{ZSA} , F_{XDA} , F_{YDA} , F_{ZDA} , M_{XDA} , M_{YDA} , M_{ZDA} .
7. The equation sets 1 through 3 found in Table 6: *Acceptance criteria equations* must be satisfied.
8. **Equation Set 1.** Each applied load is divided by the corresponding adjusted values from Table 7: *Nozzle Loading*. The absolute value of each ratio must be less than two.
9. **Equation Set 2.** Calculate the resultant applied forces and resultant adjusted Table 7: *Nozzle Loading* forces (F_{RSA} , F_{RDA} , F_{RS_adj} , F_{RD_adj}), resultant applied moments and resultant adjusted Table 7 moments (M_{RSA} , M_{RDA} , M_{RS_adj} , M_{RD_adj}). Calculate the ratios and summations listed in the equations. The final values must be less than two.

10. **Equation Set 3.** From Table 8: *Pump Nozzles to Centerline*, find the distance from the center of the pump to the suction and discharge nozzles, x_S and z_D . Translate the applied component forces and moments applied to each pump nozzle flange to the center of the pump. Calculate component loads at the center of the pump, F_{XCA} , F_{YCA} , F_{ZCA} , M_{XCA} , M_{YCA} , M_{ZCA} . Calculate the resultant loads at the center of the pump F_{RCA} , M_{RCA} . These values shall be limited by the formula shown.

Table 4: Casing Material Correction Factor

Temp °C (°F)	Material Group No.												
	1.0	1.1	2.1	2.2	2.3	2.4	2.8	3.1	3.2	3.4	3.5	3.7	3.8
	Ductile Iron	Carbon steel	Austenitic Steels					Nickel and Nickel Alloys					
			Type 304	Type 316	Type 304L and 316L	Type 321	CD- 4MCuN	Alloy 20	Nickel	Monel	Inconel	Hast. B	Hast. C
-29 to 38 (-20 to 100)	0.89	1.00	1.00	1.00	0.83	1.00	1.00	0.83	0.50	0.83	1.00	1.00	1.00
93 (200)	0.83	0.94	0.83	0.86	0.70	0.98	1.00	0.77	0.50	0.74	0.93	1.00	1.00
149 (300)	0.78	0.91	0.74	0.78	0.63	0.83	1.00	0.73	0.50	0.69	0.89	1.00	1.00
204 (400)	0.73	0.88	0.65	0.72	0.58	0.69	0.98	0.67	0.50	0.67	0.85	0.98	0.98

Table 5: Baseplate Correction Factor

Baseplate	Grouted	Bolted
Type D	1.00	0.80
Type E – PIP	1.00	0.95

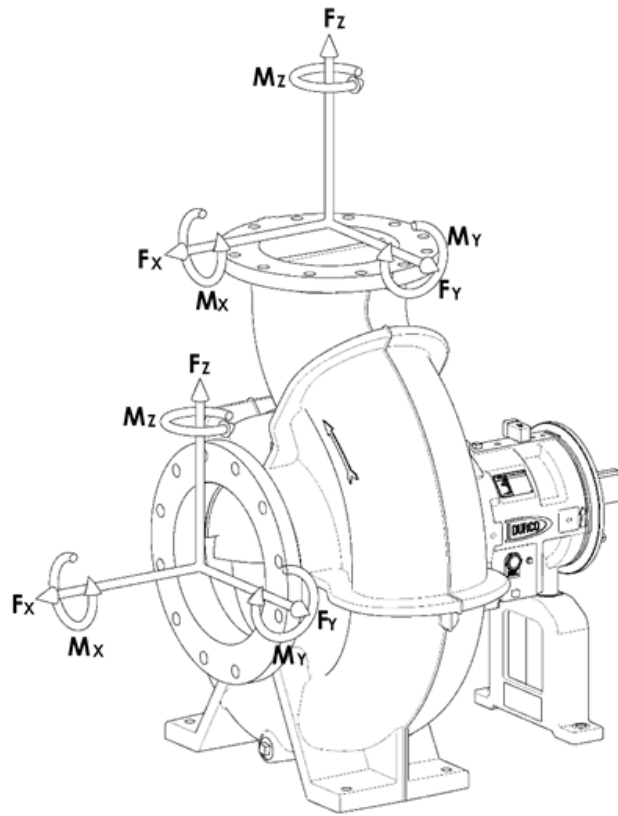

Figure 5: Coordinate system

Table 6: Acceptance criteria equations

Set	Equations	Remarks
1	$\left \frac{F_{XSA}}{F_{XS_adj}} \right < 2.0, \left \frac{F_{YSA}}{F_{YS_adj}} \right < 2.0, \left \frac{F_{ZSA}}{F_{ZS_adj}} \right < 2.0, \left \frac{M_{XSA}}{M_{XS_adj}} \right < 2.0, \left \frac{M_{YSA}}{M_{YS_adj}} \right < 2.0, \left \frac{M_{ZSA}}{M_{ZS_adj}} \right < 2.0,$ $\left \frac{F_{XDA}}{F_{XD_adj}} \right < 2.0, \left \frac{F_{YDA}}{F_{YD_adj}} \right < 2.0, \left \frac{F_{ZDA}}{F_{ZD_adj}} \right < 2.0, \left \frac{M_{XDA}}{M_{XD_adj}} \right < 2.0, \left \frac{M_{YDA}}{M_{YD_adj}} \right < 2.0, \left \frac{M_{ZDA}}{M_{ZD_adj}} \right < 2.0$	Maximum Individual Loading
2	$F_{RSA} = \sqrt{F_{XSA}^2 + F_{YSA}^2 + F_{ZSA}^2}, M_{RSA} = \sqrt{M_{XSA}^2 + M_{YSA}^2 + M_{ZSA}^2}$ $F_{RDA} = \sqrt{F_{XDA}^2 + F_{YDA}^2 + F_{ZDA}^2}, M_{RDA} = \sqrt{M_{XDA}^2 + M_{YDA}^2 + M_{ZDA}^2}$ $F_{RS_adj} = \sqrt{F_{XS_adj}^2 + F_{YS_adj}^2 + F_{ZS_adj}^2}, M_{RS_adj} = \sqrt{M_{XS_adj}^2 + M_{YS_adj}^2 + M_{ZS_adj}^2}$ $F_{RD_adj} = \sqrt{F_{XD_adj}^2 + F_{YD_adj}^2 + F_{ZD_adj}^2}, M_{RD_adj} = \sqrt{M_{XD_adj}^2 + M_{YD_adj}^2 + M_{ZD_adj}^2}$ $\frac{F_{RSA}}{1.5 \times F_{RS_adj}} + \frac{M_{RSA}}{1.5 \times M_{RS_adj}} < 2.0$ $\frac{F_{RDA}}{1.5 \times F_{RD_adj}} + \frac{M_{RDA}}{1.5 \times M_{RD_adj}} < 2.0$	Resultant loads on each nozzle
3	$F_{XCA} = F_{XSA} + F_{XDA}, F_{YCA} = F_{YSA} + F_{YDA}, F_{ZCA} = F_{ZSA} + F_{ZDA}$ <p>For SI units, 1000 is used to convert millimeters to meter in the following equations.</p> $M_{XCA} = M_{XSA} + M_{XDA} - F_{YDA} \times zD/1000$ $M_{YCA} = M_{YSA} + M_{YDA} + (F_{XDA} \times zD - F_{ZSA} \times xS)/1000$ $M_{ZCA} = M_{ZSA} + M_{ZDA} + F_{YSA} \times xS/1000$ <p>For USC units, 12 should be used to convert inch to foot.</p> $M_{XCA} = M_{XSA} + M_{XDA} - F_{YDA} \times zD/12$ $M_{YCA} = M_{YSA} + M_{YDA} + (F_{XDA} \times zD - F_{ZSA} \times xS)/12$ $M_{ZCA} = M_{ZSA} + M_{ZDA} + F_{YSA} \times xS/12$ $F_{RCA} = \sqrt{F_{XCA}^2 + F_{YCA}^2 + F_{ZCA}^2}, M_{RCA} = \sqrt{M_{XCA}^2 + M_{YCA}^2 + M_{ZCA}^2}$ $F_{RCA} < 1.5 \times (F_{RS_adj} + F_{RD_adj})$ $M_{RCA} < 1.5 \times (M_{RS_adj} + M_{RD_adj})$ $ M_{YCA} < 2.0 \times (M_{YS_adj} + M_{YD_adj})$	Resultant loads at pump center

Table 7: Nozzle Loading

Pump size	Suction Flange						Discharge Flange					
	Force N (lbf)			Moments Nm (lbf•ft)			Force N (lbf)			Moments Nm (lbf•ft)		
	Fxs	Fys	Fzs	Mxs	Mys	Mzs	Fxd	Fyd	Fzd	Mxd	Myd	Mzd
12X10-16	8 000 (1 800)	6 670 (1 500)	5 340 (1 200)	6 100 (4 500)	2 980 (2 200)	4 610 (3 400)	5 340 (1 200)	4 450 (1 000)	6 670 (1 500)	5 020 (3 700)	2 440 (1 800)	3 800 (2 800)
14X14-16	8 900 (2 000)	7 120 (1 600)	5 780 (1 300)	6 370 (4 700)	3 120 (2 300)	4 750 (3 500)	7 120 (1 600)	5 780 (1 300)	8 900 (2 000)	6 370 (4 700)	3 120 (2 300)	4 750 (3 500)
8X4-19	4 890 (1 100)	3 780 (850)	3 110 (700)	3 530 (2 600)	1 760 (1 300)	2 580 (1 900)	1 420 (320)	1 160 (260)	1 780 (400)	1 330 (980)	680 (500)	1 000 (740)
8X6-19	4 890 (1 100)	3 780 (850)	3 110 (700)	3 530 (2 600)	1 760 (1 300)	2 580 (1 900)	2 490 (560)	2 050 (460)	3 110 (700)	2 300 (1 700)	1 180 (870)	1760 (1 300)
10X6-19	6 670 (1 500)	5 340 (1 200)	4 450 (1 000)	5 020 (3 700)	2 440 (1 800)	3 800 (2 800)	2 490 (560)	2 050 (460)	3 110 (700)	2 300 (1 700)	1 180 (870)	1 760 (1 300)
12X10-19	8 000 (1 800)	6 670 (1 500)	5 340 (1 200)	6 100 (4 500)	2 980 (2 200)	4 610 (3 400)	5 340 (1 200)	4 450 (1 000)	6 670 (1 500)	5 020 (3 700)	2 440 (1 800)	3 800 (2 800)
14X12-19	8 900 (2 000)	7 120 (1 600)	5 780 (1 300)	6 370 (4 700)	3 120 (2 300)	4 750 (3 500)	6 670 (1 500)	5 340 (1 200)	8 000 (1 800)	6 100 (4 500)	2 980 (2 200)	4 610 (3 400)
10X8-19	6 670 (1 500)	5 340 (1 200)	4 450 (1 000)	5 020 (3 700)	2 440 (1 800)	3 800 (2 800)	3 780 (850)	3 110 (700)	4 890 (1 100)	3 530 (2 600)	1 760 (1 300)	2 580 (1 900)
16X16-19	10 230 (2 300)	8 450 (1 900)	6 670 (1 500)	7 320 (5 400)	3 660 (2 700)	5 420 (4 000)	8 450 (1 900)	6 670 (1 500)	10 230 (2 300)	7 320 (5 400)	3 660 (2 700)	5 420 (4 000)
12X8-22	8 000 (1 800)	6 670 (1 500)	5 340 (1 200)	6 100 (4 500)	2 980 (2 200)	4 610 (3 400)	3 780 (850)	3 110 (700)	4 890 (1 100)	3 530 (2 600)	1 760 (1 300)	2 580 (1 900)
12X10-22	8 000 (1 800)	6 670 (1 500)	5 340 (1 200)	6 100 (4 500)	2 980 (2 200)	4 610 (3 400)	5 340 (1 200)	4 450 (1 000)	6 670 (1 500)	5 020 (3 700)	2 440 (1 800)	3 800 (2 800)
14X12-22	8 900 (2 000)	7 120 (1 600)	5 780 (1 300)	6 370 (4 700)	3 120 (2 300)	4 750 (3 500)	6 670 (1 500)	5 340 (1 200)	8 000 (1 800)	6 100 (4 500)	2 980 (2 200)	4 610 (3 400)
16X14-22	10 230 (2 300)	8 450 (1 900)	6 670 (1 500)	7 320 (5 400)	3 660 (2 700)	5 420 (4 000)	7 120 (1 600)	5 780 (1 300)	8 900 (2 000)	6 370 (4 700)	3 120 (2 300)	4 750 (3 500)

Notes:

- As per ANSI/HI 9.6.2-2015 standard, table is applicable ASME B73.1 pump construction A351/A351M - Grade CF8M (type 316 SS) operated between -20 & 100 °F mounted on a grouted metal baseplate.
- These values are taken from the API 610 and it does not specify any conditions.

Table 8: Pump Nozzles Centerline

Pump size	Suction flange to pump discharge centerline, xS		Discharge flange to pump suction centerline, zD	
	mm	(in)	mm	(in)
41K12X10-16	241	(9.50)	597	(23.50)
41K14X14-16	292	(11.50)	673	(26.50)
41K8X4-19	178	(7.00)	419	(16.50)
41K8X6-19	178	(7.00)	445	(17.50)
41K10X6-19	210	(8.25)	495	(19.50)
41K12X10-19	248	(9.75)	597	(23.50)
41K14X12-19	286	(11.25)	673	(26.50)
41K10X8-19	197	(7.75)	559	(22.00)
42K16X16-19	318	(12.50)	749	(29.50)
42K12X8-22	235	(9.25)	597	(23.50)
42K12X10-22	267	(10.50)	673	(26.50)
42K14X12-22	292	(11.50)	749	(29.50)
42K16X14-22	330	(13.00)	749	(29.50)

3.5.3 Auxiliary connections

Mechanical seal

When the pump is intended to be equipped with a mechanical seal, it is Flowserve's standard practice to install the mechanical seal in the pump prior to shipment. Specific order requirements may specify that the seal be shipped separately, or none be supplied. It is the pump installer's responsibility to determine if a seal was installed. If a seal was supplied but not installed, the seal and installation instructions will be shipped with the pump.

CAUTION Failure to ensure that a seal is installed may result in serious leakage of the pumped fluid.

Seal and seal support system must be installed and operational as specified by the seal manufacturer.

The packing box/seal chamber/gland may have ports that have been temporarily plugged at the factory to keep out foreign matter. It is the installer's responsibility to determine if these plugs should be removed and external piping connected. Refer to the seal drawings and or the local Flowserve representative for the proper connections.

Packing

When the pump is intended to be equipped with shaft packing, it is not Flowserve standard practice not to install packing in the packing box prior to shipment. The packing is shipped with the pump. It is the pump installer's responsibility to install the packing in the packing box.

CAUTION Failure to ensure that the packing is installed may result in serious leakage of the pumped fluid.

3.5.3.1 Seal/packing support system

CAUTION If the pump has a seal support system, it is mandatory that this system be fully installed and operational before the pump is started.

Packing Lubrication

When the pumpage is a clean liquid and there is a positive pressure on the suction, the packing box can be packed solid and adjusted so that a slight spray leakage cools and lubricates the packing. TAP V should be plugged. The gland should be adjusted to give a flow rate of 10 to 12 drops per minute for clean fluid. Allow packing to leak freely at first and gradually tighten gland, over a 24-hour period, to the desired leakage rate. Do not overtighten the packing.

When pumpage contains abrasives, or is corrosive a cool clean liquid compatible with the pumpage, should be introduced into TAP V, as shown in Figure 6, at pressure 69 to 103 kPa (10 to 15 psi) above the packing box pressure (The packing box pressure can be obtained from Flowserve, the pump size, rotating speed, suction pressure, fluid specific gravity and impeller diameter are needed to provide the correct information.) The gland should be adjusted to give a flow rate of 40 to 60 drops per minute. For abrasive applications, the regulated flow rate should be 0.06 to 0.13 l/s (1 to 2 US gpm). FIS107 Compression Packing Installation Instructions, is available from Flowserve.

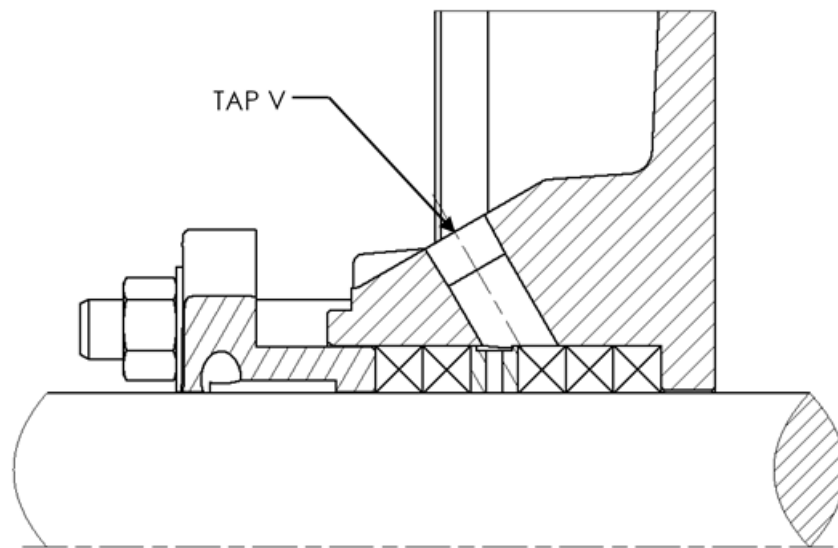

Figure 6: Grease Lube, TAP V with Packing

Grease lubrication, when compatible with the liquid being pumped, may be used. Again, introduced into TAP V.

In non-abrasive applications the liquid being pumped may be sufficient to lubricate the packing without need for external lines. Bearing housing cooling system

Make connections as shown below. Liquid at less than 32 °C (90 °F) should be supplied at a regulated flow rate of at least 0.06 l/s (1.0 US gpm).

3.5.3.2 Bearing Housing cooling system

The piping connections for jacketed covers and casings are shown below. The flow rate of the cooling water – less than 32 °C (90 °F) – should be at least 0.13 l/s (2 gpm). Do not allow the oil temperature to drop below the dew point, or condensation and contamination of the oil with water will occur.

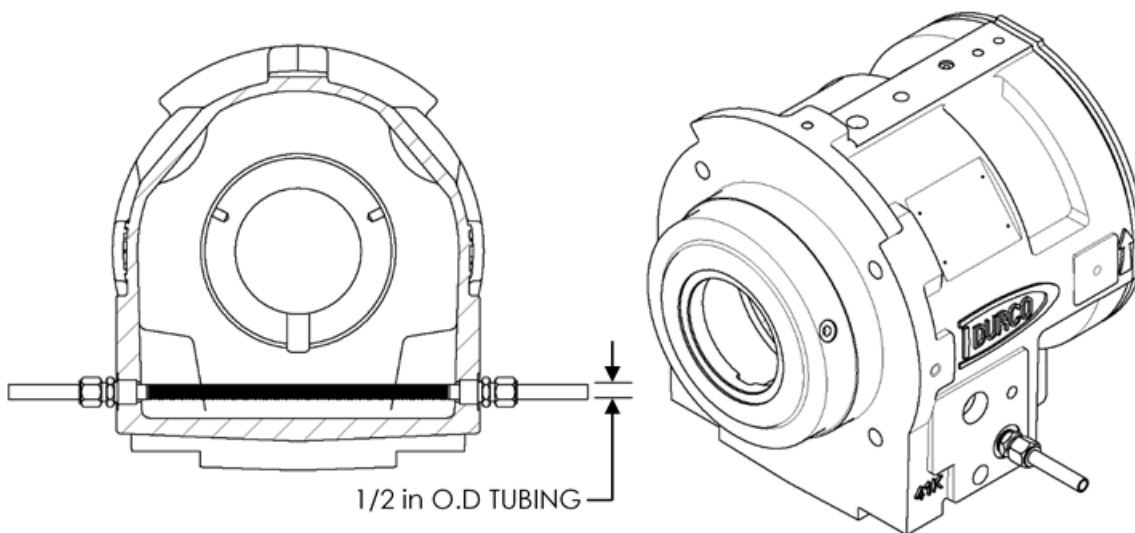

Figure 7: Bearing Housing Cooling System

3.5.3.3 Heating/cooling fluid for jacketed cover/casing

The piping connections for jacketed covers and casings are shown below. The flow rate of the cooling water – less than 32 °C (90 °F) – should be at least 0.13 l/s (2 US gpm). Jacket Maximum Design Pressure (MDP) is 689 kPa gage @ 171 °C (100 psig at 340°F).

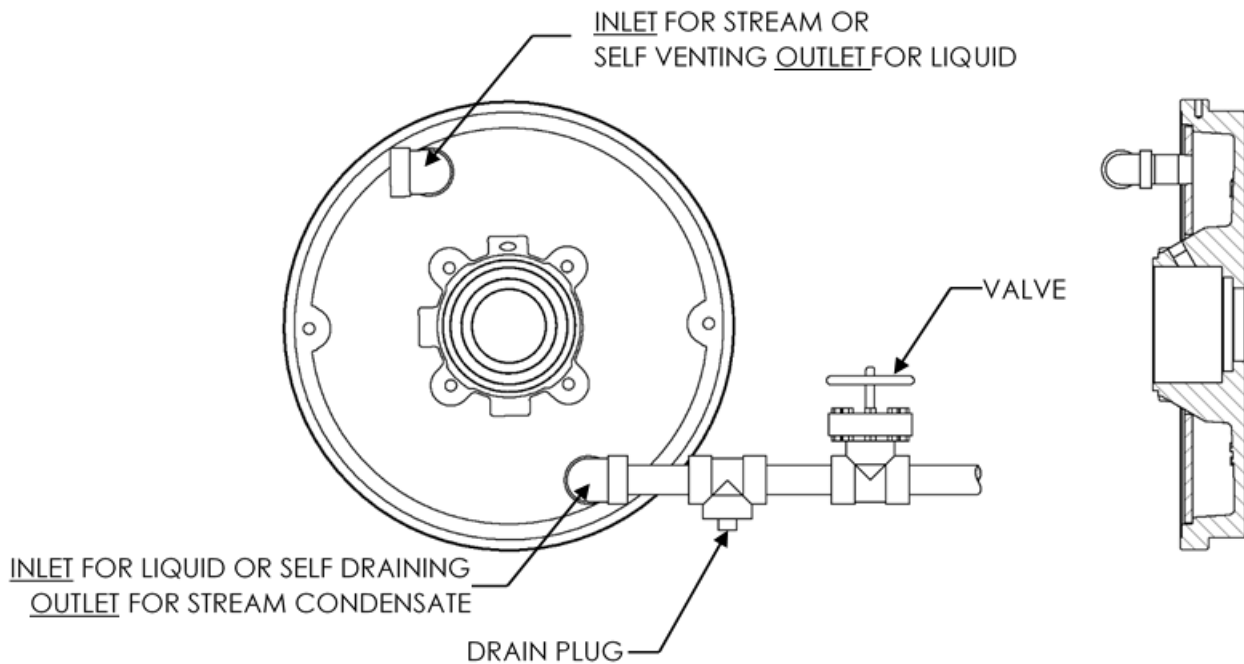

Figure 8: Heating/Cooling Fluid (cover)

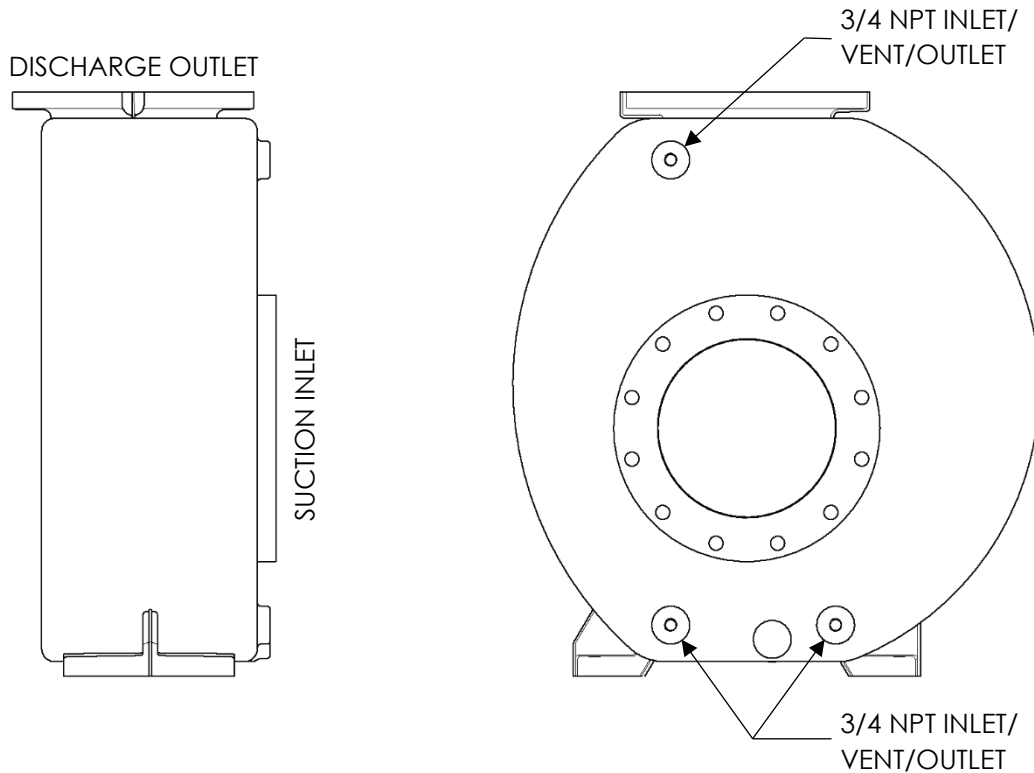

Figure 9: Heating/Cooling Fluid (casing)

NOTICE

When circulating steam, use top hole for inlet. Both bottom holes must be plumbed together for outlet, to ensure draining both sides of jacket.

NOTICE

When circulating liquid use both bottom holes as inlets. Use top hole as outlet.

3.5.3.4 Oil mist lubrication system - MPE4

The piping connection for an oil mist lubrication system are shown in Figures 10 & 11.

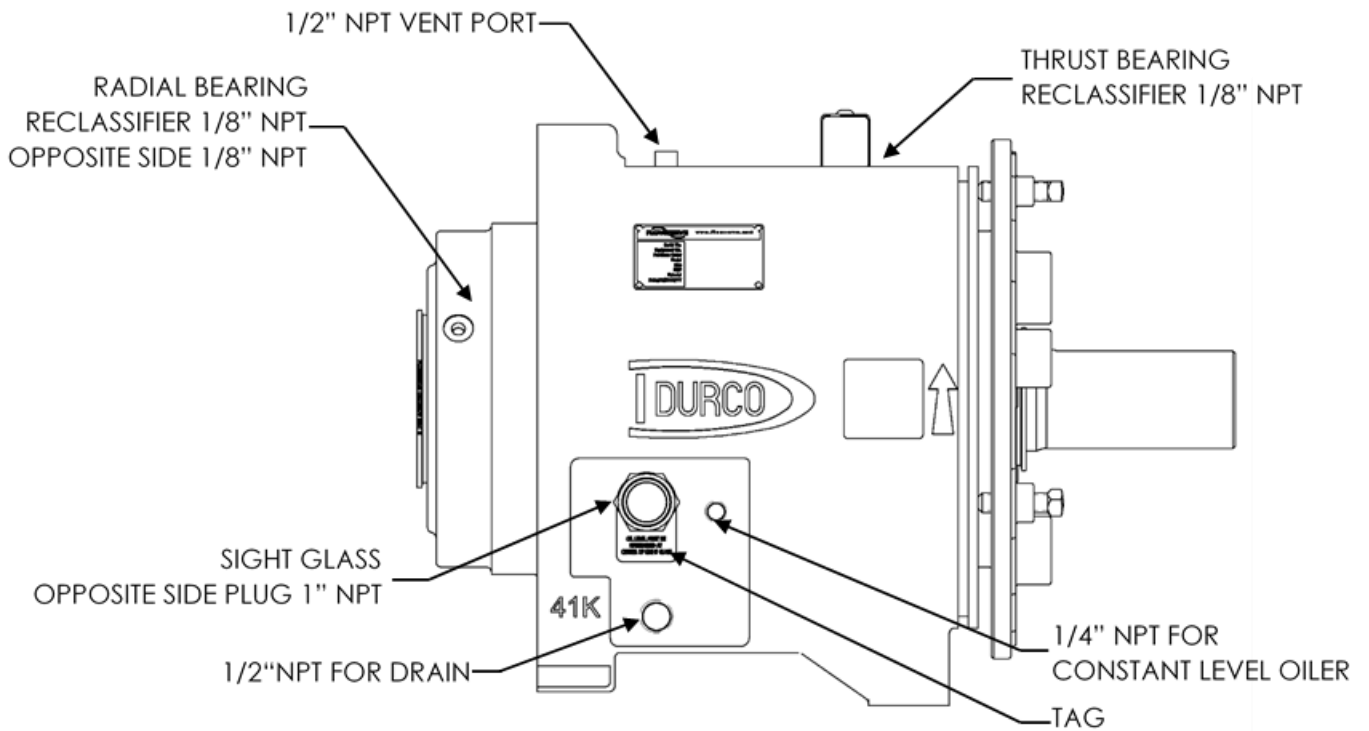

Figure 10: Oil Mist Lubrication System (wet sump)

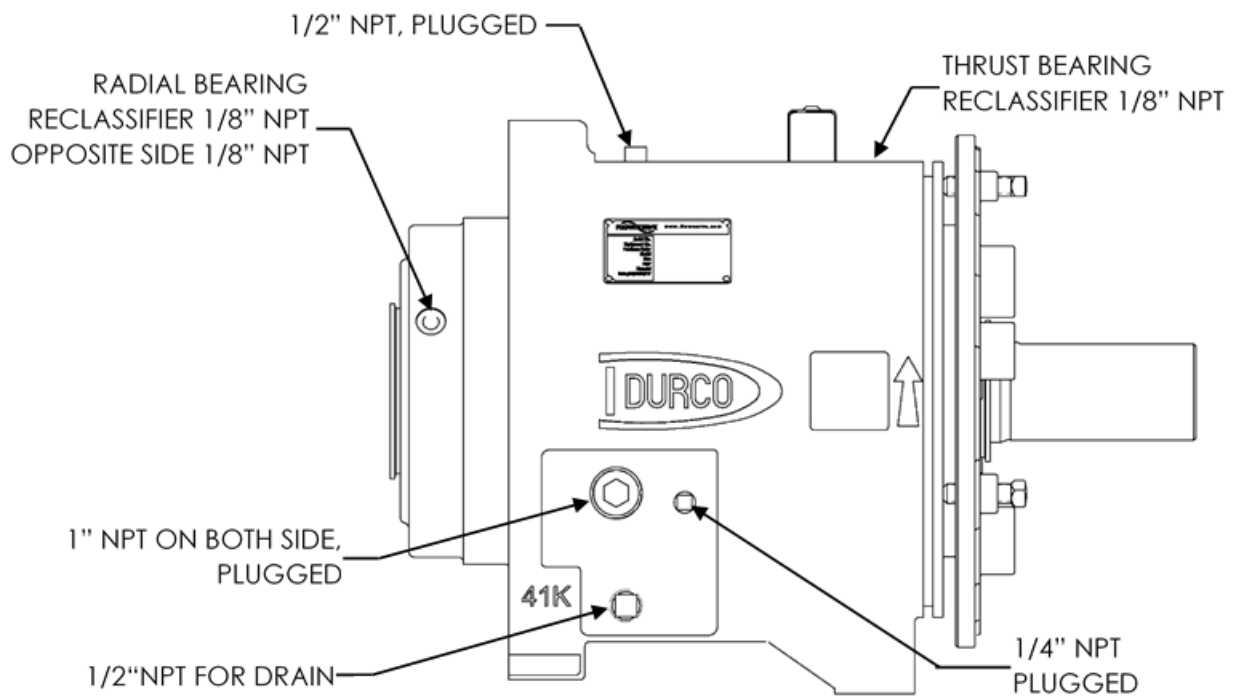

Figure 11: Oil Mist Lubrication System (dry sump)

3.6 Controls

3.6.1 Protection system



The following protection systems are recommended particularly if the pump is installed in a potentially explosive area or is handling a hazardous liquid. If in doubt consult Flowserve.

If there is any possibility of the system allowing the pump to run against a closed valve or below minimum continuous safe flow a protection should be installed to ensure the temperature of the liquid does not rise to an unsafe level.

If there are any circumstances in which the system can allow the pump to run dry, or start up empty, a power monitor should be fitted to stop the pump or prevent it from being started. This is particularly relevant if the pump is handling a flammable liquid.

If leakage of product from the pump or its associated sealing system can cause a hazard it is recommended that an appropriate leakage detection system is installed.

To prevent excessive surface temperatures at bearings it is recommended that temperature or vibration monitoring is carried out.

3.7 Accessories

If you have purchased a bare shaft pump, the following items are required for operations.

1. Mechanical Seal or Packing
2. Auxiliary piping plan for seal
3. Seal Guard
4. Coupling
5. Coupling Guard
6. Baseplate
7. Driver (typical a NEMA motor)

3.8 Tools, equipment, and fixtures







See Section 8.3, Special tools, for necessary tools/special tools needed for disassembly, maintenance and reassembly.

4 Packaging, Transportation and Storage

4.1 Consignment receipt

Immediately after receipt of the product/system it must be checked against the delivery/shipping documents for its completeness and that there has been no damage in transportation. Any shortage and/or damage must be reported immediately to Flowserve Solution Group and must be received in writing within (10) ten days of receipt of the equipment. Later claims cannot be accepted.

The following symbols are used to label the packaging:

	This side up		Fragile
	Keep dry		Protect from direct sunlight
	Centre of gravity		Do not use hooks
	Attachment point		

4.2 Unpacking

The pump and its associated equipment were carefully inspected at the factory prior to shipment, to ensure quality compliance. It is suggested that the equipment be inspected on arrival and that any irregularities or damage be reported to the carrier immediately.

The condition of the skid and covering is indicative of the way the shipment was handled. Broken skids, torn covering, bent hold down bolts, broken straps, etc. indicate rough handling. The protective covers on the pump nozzles should be in place and undamaged.

In general, care is to be taken when removing crating, coverings, and strapping in order not to damage any auxiliary equipment and/or the paint finish.

Check any crate, boxes or wrappings for any accessories or spare parts that may be packed separately with the equipment or attached to side wall of the box or equipment.

Each product has a unique serial number. Check that this number corresponds with that advised and always quote this number in correspondence as well as when ordering spare parts or further accessories.

Boxes, crates, pallets or cartons may be unloaded using fork lift vehicles or slings dependent on their size and construction.

4.3 Packaging

The equipment has been packaged in a suitable container or transporting device that protects the material from exterior forces or impact, vibration, and environmental conditions normally encountered during transportation. Flowserve completes the following in preparation for shipment:

1. All items are inspected for cleanliness immediately before packaging. Dirt, oil residue, metal chips or other forms of contamination are removed by approved cleaning methods.
2. Components which are not immediately packaged, are protected from contamination and oxidation. Package with a barrier such that water vapor, salt air, dust, dirt and other forms of contamination do not penetrate the package.
3. Items that can be damaged by condensation trapped within the package are packaged with approved desiccant inside the water vapor proof barrier or by an equivalent method.
4. Items and their containers are properly identified by markings.

It is Flowserve's responsibility to ensure that materials and products are handled, prior to shipment, in a manner that will prevent deterioration or damage to the product or personnel.

Material that has been subjected to conditions that may result in hidden damage are disassembled as required and inspected. A record of the inspection is retained in the appropriate job file or quality records.

Additional care should be taken, by all involved parties, to ensure that the quality of items being loaded/unloaded will not be damaged.

Before shipping, a packing slip is prepared and fasten it to the unit. The packing slip contain the following information:

1. Customer's Purchase Order Number.
2. Flowserve Job Number.
3. Customer's Name and Address.
4. "Ship to" Address.
5. Quantity.
6. Description.
7. Date Shipped.
8. Carrier Used.

For shipments with more than one-unit container or package for any given order, each parcel is marked as 1 of 3, 2 of 3, etc., and contain a copy of the packing list.

4.4 Transportation



A crane must be used for all pump sets more than 23 kg (50 lb). Fully trained personnel must carry out lifting, in accordance with local regulations.

Sling, ropes and other lifting gear should be positioned where they cannot slip and where a balanced lift is obtained. The angle between sling or ropes used for lifting must not exceed 60°.

CAUTION

Pumps and motors often have integral lifting lugs or eye bolts. These are intended for use in only lifting the individual piece of equipment.

CAUTION

Do not use eye bolts or cast-in lifting lugs to lift pump, motor and baseplate assemblies.

NOTICE

To avoid distortion, the pump unit should be lifted as shown.

CAUTION

Care must be taken to lift components or assemblies above the center of gravity to prevent the unit from flipping.

4.4.1 Lifting pump components

For component or assembled components that weigh more than 23 kg (50 lb), Flowserve uses the technique below to properly transport components during assembly or disassembly procedures. If the site does not utilize rigging equipment mentioned, use the facilities' procedures while adhering to each component's lifting procedures.

4.4.1.1 Casing [1100]

Use a choker hitch sling pulled tight around the discharge nozzle. See Figure 17: Lifting Bare Pump, for the casing rigging technique.

4.4.1.2 Cover [1220]

With the back pullout assembly secured to the work surface, See Figure 51: Removing Impeller, Insert a long shank eyebolt in the drilled and taped hole at the top of the cover. Sling or hook through the eye of the eyebolt. Install the (2) Token bolt cap screws [6570.6] before removing tension from load.

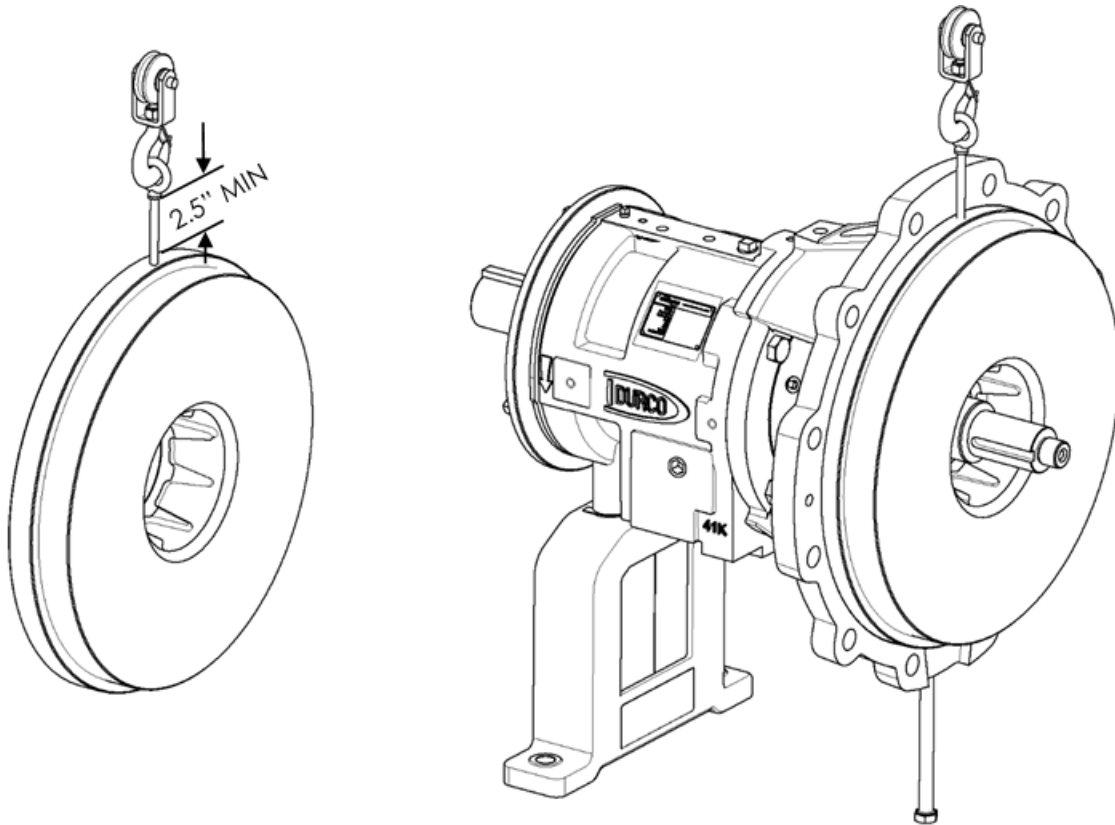

Figure 12: Lifting Cover

4.4.1.3 Impeller [2200]

Use a clamp suitable for lifting the impeller, as shown in Figure 13. A suitable clamp example is a Campbell® GX clamp no. 642300. *Read all safety instruction for the lifting device used.*

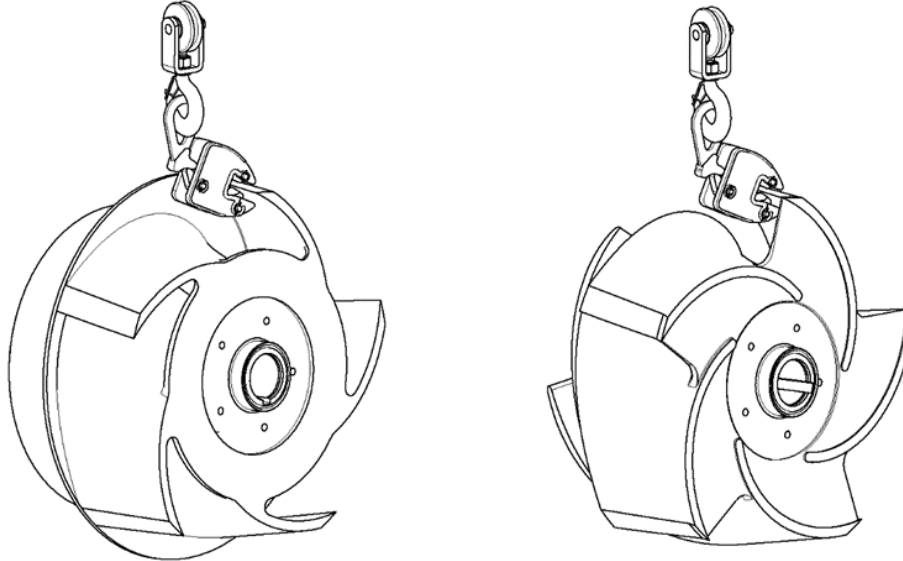

Figure 13: Lifting Impeller

4.4.1.4 Adapter [1340]

Insert hitch choker sling in openings of adapter, ensure a tight fit, as shown in Figure 14.

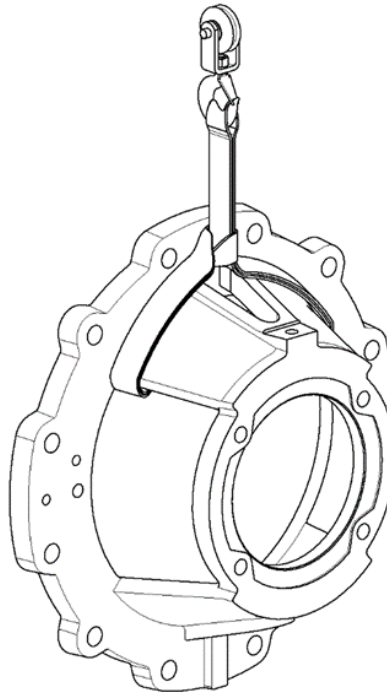

Figure 14: Lifting Adapter

4.4.1.5 Bearing housing [3200]

Insert either a sling or hook through a Shoulder Type Machinery Eye Bolt, installed on the top of the housing
with the Eye Bolt shoulder squarely against the bearing housing, as shown in Figure 15.

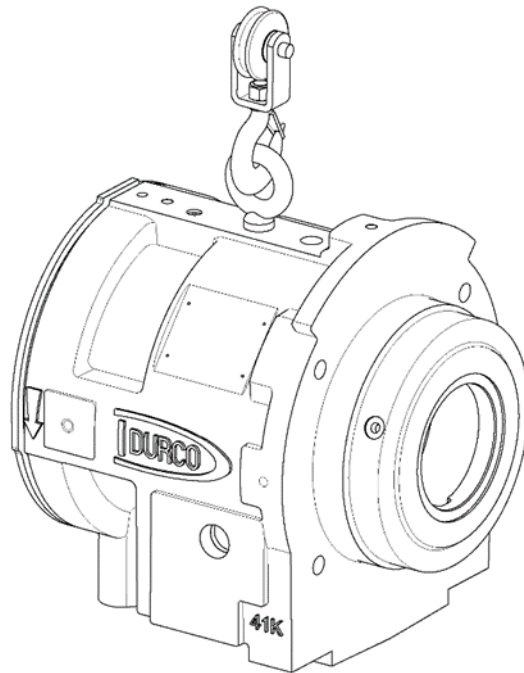

Figure 15: Lifting Bearing Housing

4.4.1.6 Back Pullout Assembly (Power end)

Insert hitch choker sling in openings of adapter, ensure tight fit, or hook through a Shoulder Type Machinery Eye Bolt, installed on the top of the adapter, with the Eye Bolt shoulder squarely against the adapter, as shown in Figure 16.

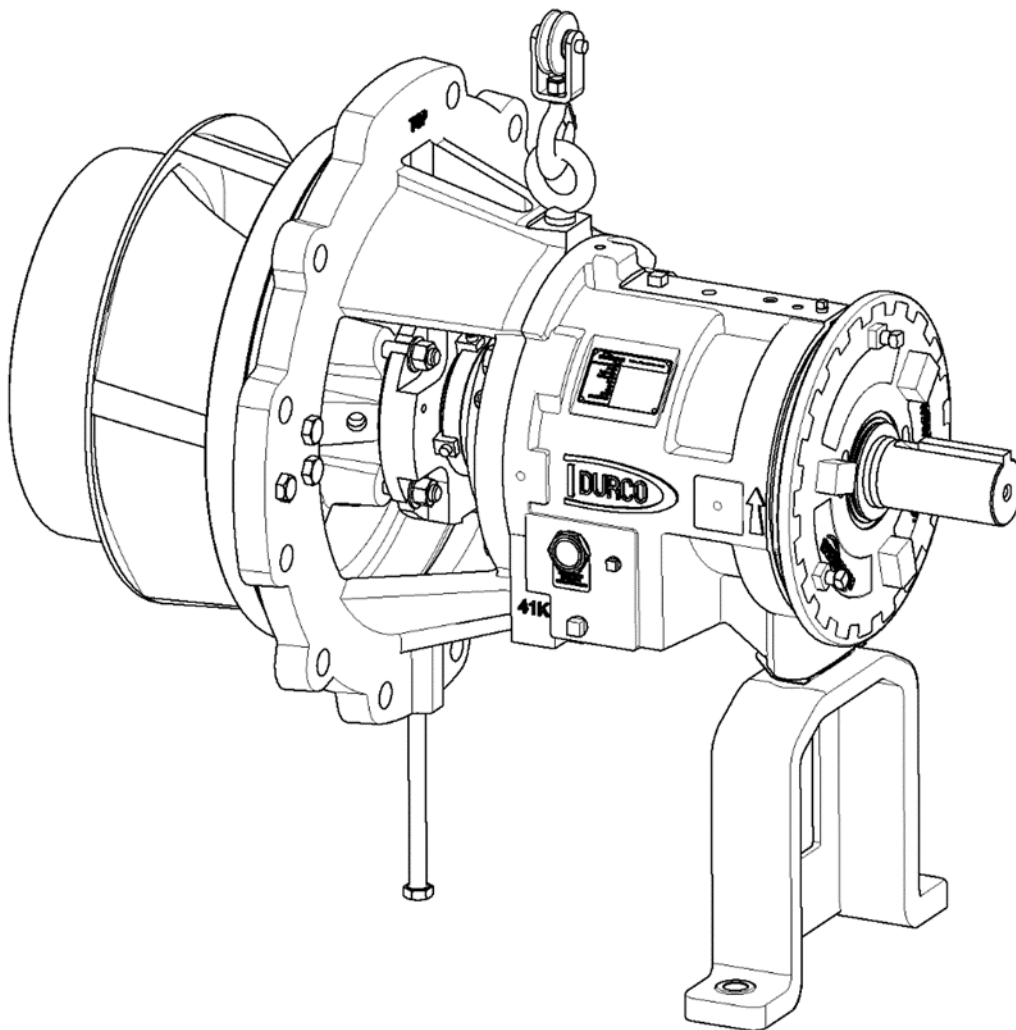

Figure 16: Lifting Back Pullout Assembly

4.4.1.7 Bare pump

Sling around the pump discharge nozzle. This is sufficient to lift the pump level in most instances. If the pump does not lift level, choke around the outboard end of the bearing housing with second sling. Choker hitches must be pulled tight at each attachment. The choker hitch on the discharge nozzle is towards the coupling end of the pump shaft, as shown in Figure 17. If two slings are used, sling lengths should be adjusted to balance the load before attaching the lifting hook.

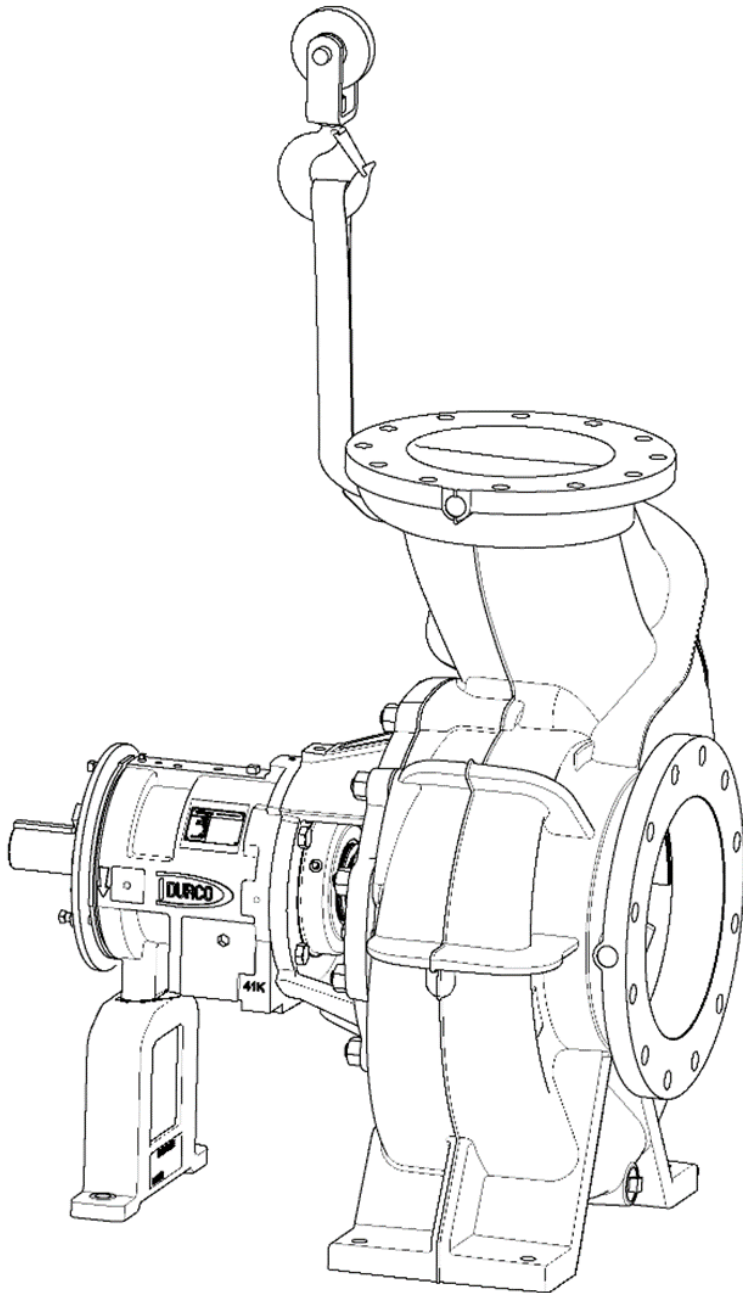

Figure 17: Lifting Bare Pump
Page **43** of **139**

4.4.1.8 Assembled pump with baseplate and motor

Use spreader beams with dropper chains attached to a lifting beam, as shown in Figure 18. This method eliminates compressive loads on the baseplate. Do not use slings through the lifting holes. Using lifting holes located in the baseplate corners (Type D and Type E bases), hook with SOS chain slings, connect the master links to the spreader beam hooks. Attach the spreader beam master links to the lifting beam hooks. Adjust the lifting beam bail to balance the load.

CAUTION Do not lift or transport baseplates with motors larger than a NEMA 449 Frame, or above 1590 kg (3500 lb). Permanent damage to the baseplate may result.

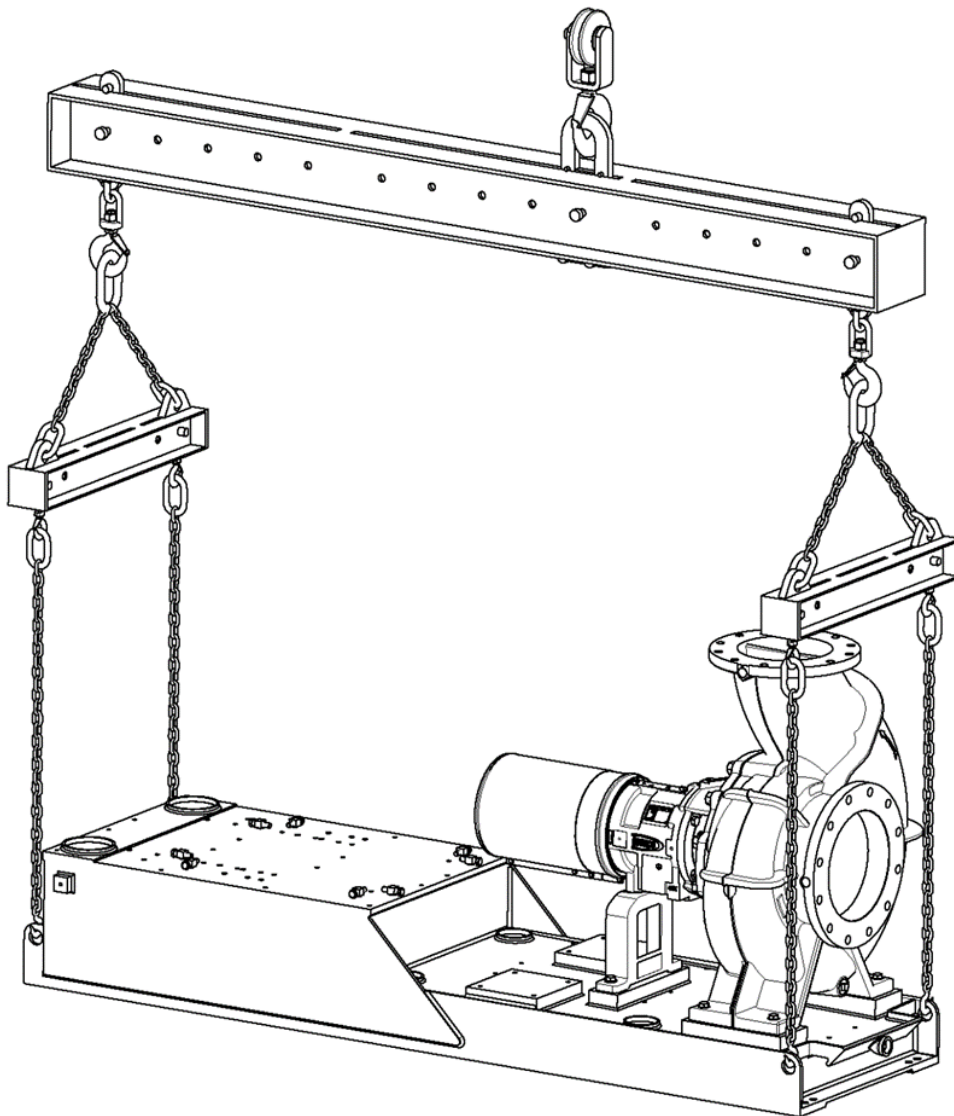

Figure 18: Lifting Assembled Pump with Baseplate

4.5 Storage and packing

NOTICE

Store the pump in a clean, dry location away from vibration. Leave flange covers in place to keep dirt and other foreign material out of the pump casing. Turn the pump shaft at regular intervals to prevent brinelling of the bearings and the seal faces, if fitted, from sticking.

The pump may be stored as above for up to six months. Consult Flowserve for preservative actions when a longer storage period is needed.

4.5.1 Short term procedures

Normal packaging is designed to protect the pump and parts during shipment and for dry, indoor storage for up to six months or less. The following is an overview of our normal packaging:

1. All loose unmounted items are packaged in a water proof plastic bag and placed under the coupling guard
2. Inner surfaces of the bearing housing, shaft (area through bearing housing) and bearings are coated with Cortec VpCl®-329 rust inhibitor, or equal

NOTICE

Bearing housing are not filled with oil prior to shipment

3. Re-greaseable bearings are packed with grease (EXXON POLYREX EM for horizontal pumps)
4. The internal surface of ferrous casings, covers, flange faces, and the impeller surface are sprayed with Cortec VpCl®-389, or equal
5. Exposed shafts are taped with Polywrap
6. Flange covers are secured to both the suction and discharge flanges
7. In some cases, with assemblies ordered with external piping, components may be disassembled for shipment
8. The pump must be stored in a covered, dry location

4.5.2 Long term storage and packing

Long term storage is defined as more than six months, but less than twelve months. The procedure Flowserve follows for long-term storage of pumps is given below. These procedures are in addition to the short-term procedure.

1. Each assembly is hermetically (heat) sealed from the atmosphere by means of tack wrap sheeting and rubber bushings (mounting holes)
2. Desiccant bags are placed inside the track wrapped packaging
3. A solid wood box is used to cover the assembly

This packaging will provide protection for up to twelve months from humidity, salt laden air, dust etc.

After unpacking, protection will be the responsibility of the user. Addition of oil to the bearing housing will remove the inhibitor. If units are to be idle for extended periods after addition of lubricants, inhibitor oils, and greases should be used. Every three months, the pump shaft should be rotated approximately ten (10) revolutions.

5 Installation

5.1 Inspection and preparation

5.1.1 Location

The pump should be located to allow room for access, ventilation, maintenance, and inspection with ample headroom for lifting and should be as close as practicable to the supply of liquid to be pumped. Refer to the general arrangement drawing for the pump set.

5.1.2 Part assemblies

The supply of motors and baseplates are optional. Equipment must be removed from the baseplate, when installed correctly. *It is the responsibility of the installer to align the pump and motor set, as detailed in Section 5.3 Installation.*

5.1.3 Protection of openings and threads

When the pump is shipped, all taped connection, threads and all openings are covered or plugged. This protection/covering should not be removed until installation. If for any reason, the pump is removed from service, this protection should be reinstalled. When equipment is removed from the baseplate, in a non-weather protected location, reinstall hardware with Henkel Loctite® 242 locker and sealant applied to thread. This prevents moisture and debris from entering unprotected threaded hole.

5.1.4 Rigid baseplate – overview

The baseplate provides a rigid foundation for the pump and driver. Its primary function is to maintain alignment between the pump and driver shafts. Two styles of grouted baseplates are available for the Mark 3 Group 4, Type D and Type E, as shown in Figure 19.

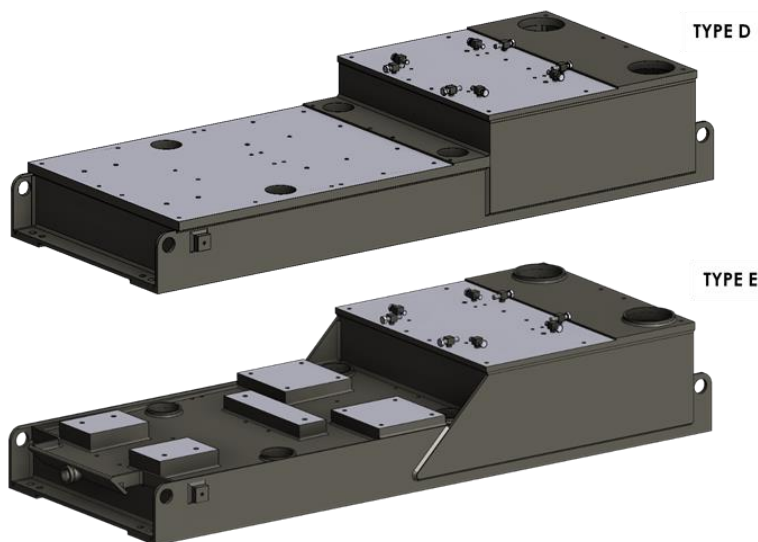

Figure 19: Type D & Type E Baseplates

Baseplates intended for grouted installation are designed to use the grout as a stiffening member. It must provide certain functions that ensure a reliable installation. Three of these requirements are:

1. The baseplate must provide sufficient rigidity to assure the assembly can be transported and installed, given reasonable care in handling, without damage. It must also be rigid enough when properly installed to resist operating loads.

NOTICE

After factory pre-alignment verification is completed, motors larger than a NEMA 449T frame are unmounted, packaged and shipped separately from the pump and baseplate.

2. The baseplate must provide a reasonably flat mounting surface for the pump and driver. Uneven surfaces will result in a soft-foot condition that may make alignment difficult or impossible. Experience indicates that a baseplate with a top surface flatness of 1.25 mm/m (0.015 in/ft) across the diagonal corners of the baseplate provides such a mounting surface. Therefore, this is the tolerance to which we supply our standard Type D baseplate. Some users may desire an even flatter surface, which complies with API 686-2009 Section 3 paragraph 3.9.4.4 for level requirements. Flowserve will supply flatter baseplates upon request at extra cost. For example, mounting surface flatness of 0.17 mm/m (0.002 in/ft) is offered, as standard, on the Flowserve Type E "Ten Point" baseplate, as shown in Figure 19.
3. The baseplate must be designed to allow the user to final field align the pump and driver to within their own particular standards and to compensate for any pump or driver movement that occurred during handling. Normal industry practice is to achieve final alignment by moving the motor to match the pump. Flowserve practice is to pre-align confirm in our shop that the pump assembly can be accurately aligned. Before shipment, the factory verifies that there is enough horizontal movement capability at the motor to obtain a "perfect" final alignment when the installer puts the baseplate assembly into its original, top levelled, unstressed condition. When a baseplate, pump and motor assembly is supplied as a unit, a label showing the completed pre-alignment verification results is attached to the coupling guard.

5.2 Baseplate mounting

The following steps are grouting instructions to install Type D and Type E baseplates.

5.2.1 Mounting grouted baseplates

1. The pump foundation should be located as close to source of the fluid to be pumped as practical.
2. There should be adequate space for workers to install, operate, and maintain the pump. The foundation should be sufficient to absorb any vibration and should provide a rigid support for the pump, motor and baseplate.
3. Recommended mass of a concrete foundation should be at minimum three times that of the pump, motor and base. Refer to Figure 20

NOTICE

Foundation bolts are imbedded in the concrete inside a sleeve to allow some movement of the anchor.

NOTICE

If the baseplate is sandblasted in preparation for grouting, all equipment must be removed and protected from blasting media.

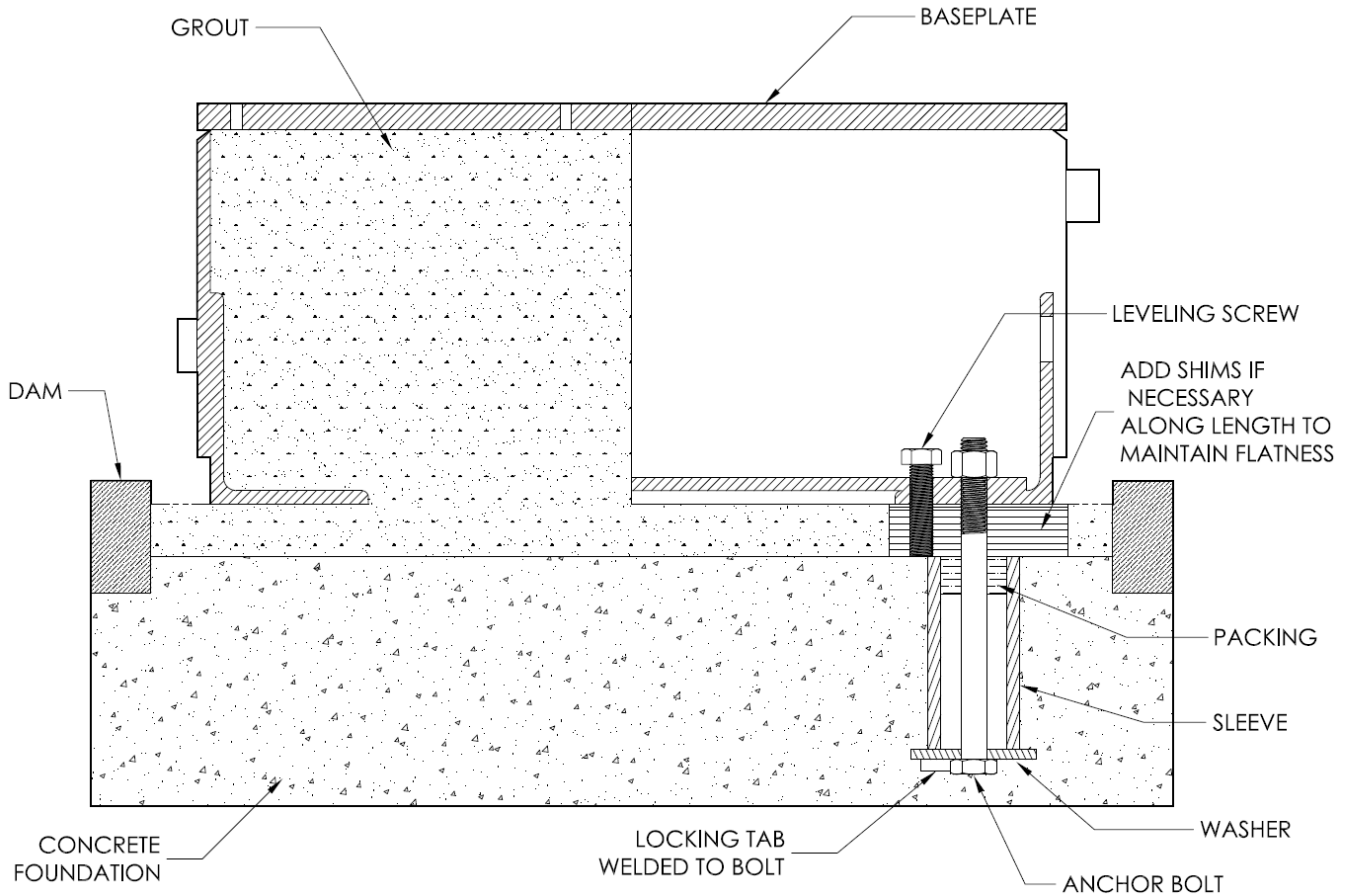

Figure 20: Grouted Mount Baseplate

4. Level Type D baseplate mounting surfaces longitudinally and transversely within 1.25 mm/m (0.015 in/ft). Level Type E baseplate mounting surfaces longitudinally and transversely within 0.42 mm/m (0.005 in/ft); level within 0.30 mm/m (0.0035 in/ft) is achievable in most cases, but not required. The machined coplanar and parallel mounting surfaces are to be referenced when levelling the baseplate. This may require that the pump and motor be removed from the baseplate to reference the machined faces. DO NOT stress the baseplate.
5. Do not bolt the suction or discharge flanges of the pump to the piping, until the baseplate foundation is completely installed. Use levelling jackscrews to level the baseplate. Check for levelness in both the longitudinal and lateral directions, to values in paragraph 4. If necessary, shims should be placed along the middle edge of the base. Do not rely on the bottom of the baseplate to be flat. The bottom baseplate surface is not machined, and it is unlikely that the field mounting surface is flat.
6. After levelling the baseplate, tighten the anchor bolts. If shims were used, make sure that the levelling screws are in contact with the foundation before tightening. Failure to do this may result in a twist of the baseplate, which could make it impossible to obtain final alignment.

7. Check the level of the baseplate to make sure that tightening the anchor bolts did not disturb the level of the baseplate. If the anchor bolts did change the level, adjust the levelling screws, and shims if used, as needed to level the baseplate.
8. Continue adjusting the levelling screws and tightening the anchor bolts until the baseplate is level.
9. Check initial alignment. If the pump and/or motor were removed from the baseplate proceed with step 10 first, then the pump and/or motor should be reinstalled onto the baseplate using Flowserve's factory preliminary alignment procedure as described in Section 5.2.2, and then continue with the following. As described above, pumps are given a preliminary alignment at the factory. This preliminary alignment is done in a way that ensures that, if the installer duplicates the factory conditions, there will be sufficient clearance between the motor hold down bolts and motor foot holes to move the motor into final alignment. If the pump and motor were properly reinstalled to the baseplate or if they were not removed from the baseplate and there has been no transit damage, and if the above steps were done properly, the pump and driver should be within 0.38 mm (0.015 in) FIM (Full Indicator Movement) parallel, and 0.0025 mm/mm (0.0025 in/in) FIM angular. If this is not the case, first check to see if the driver mounting fasteners are centered in the driver feet holes. If not, re-center the fasteners and perform a preliminary alignment to the above tolerances by shimming under the motor for vertical alignment, and by moving the pump for horizontal alignment.
10. Grout the baseplate. A non-shrinking grout should be used. Make sure the grout fills all areas under the baseplate. After the grout has cured, check for voids and repair them. Jackscrews, shims and wedges should be removed from under the baseplate at this time. If they were to be left in place, they could rust, swell, and cause distortion in the baseplate. Fill the voids left from removal of the jackscrews and shims with flexible seam sealant.
11. After grouting baseplate some distortion may occur during grouting cure. The post-grout cure level criterion, for Type E baseplates, is a maximum of 0.67 mm/m (0.008 in/ft) (both longitudinally and transversely). For Type D baseplates the criterion, is a maximum of 1.50 mm/m (0.018 in/ft) Mounting plates that settle unevenly and/or beyond the specified level tolerance shall be corrected. Correction of level may include removal and regrouting or field machining of the equipment mounting surfaces.
12. Run piping to the suction and discharge of the pump. There should be no piping loads transmitted to the pump after connection is made. Place dial indicators vertically and horizontally at the end of the pump shaft. Zero the indicators and observe any movement as the suction flange fasteners are tightened in increments of 10%, 30%, 60% and 100% of the required final torque. (See ASME PCC-1-2013 for additional details) Repeat the process on the discharge flange. Movement more than 0.05 mm (0.002 in), indicates excess pipe strain is present. Loosen flange fasteners, remove the flange gasket, and correct the source of pipe strain. Replace the flange gasket(s), and then repeat this step until pipe strain is eliminated.

5.2.2 Initial alignment procedure

The purpose of factory alignment is to ensure that the user will have full utilization of the clearance in the motor holes for final job-site alignment. To achieve this, the factory alignment procedure specifies that the pump be aligned in the horizontal plane to the motor, with the motor foot bolts centered in the motor holes. This procedure ensures that there is sufficient clearance in the motor holes for the customer to field align the motor to the pump, to zero tolerance. This philosophy requires that the customer can place the base in the same condition as the factory. Thus, the factory alignment will be done with the base sitting in an unrestrained

condition on a flat and level surface. This standard also emphasizes the need to ensure that shaft spacing is adequate to accept the specified coupling spacer.

The factory alignment procedure is summarized below:

1. The baseplate is placed on a flat and level workbench in a free and unstressed position.
2. The baseplate is levelled as necessary. Levelling is accomplished by placing shims under the rails of the base at the appropriate anchor bolt hole locations. Levelness is checked in both the longitudinal and lateral directions.
3. The motor and appropriate motor mounting hardware is placed in the baseplate and the motor is checked for any planar soft-foot condition. If any is present it is eliminated by shimming.
4. The motor feet holes are centered on the motor mounting fasteners. This is done by using a centering nut, as shown in Figure 21.

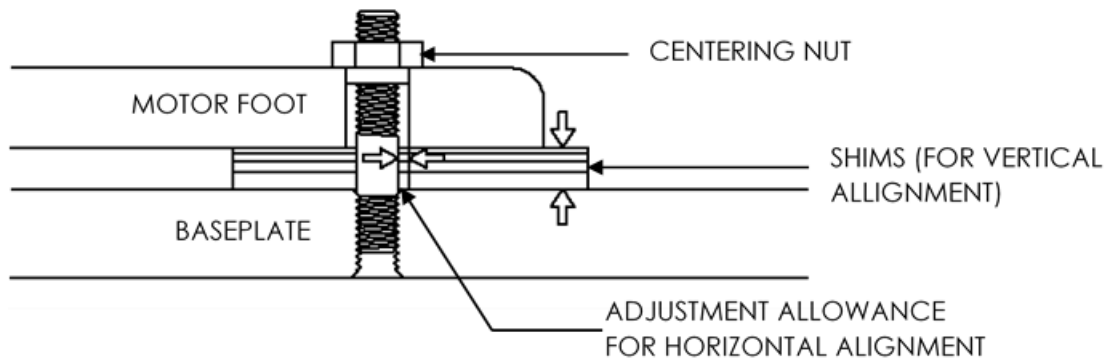

Figure 21: Center Mounting Feet Holes

5. The motor is fastened in place by tightening the nuts on two diagonal motor mounting studs.
6. The pump is put onto the baseplate and levelled. The foot piece under the bearing housing is adjustable. It is used to level the pump, if necessary.

NOTICE

If an adjustment is necessary, add or remove shims [3126.1] between the foot piece and the bearing housing.

The standard shim [3126.1] thickness is 0.76 mm (0.030 in); 0.13 mm (0.005 in) and 0.25 mm (0.010 in) are available.

7. The spacer coupling gap is verified.
8. The parallel and angular vertical alignment is made by shimming under the motor.
9. The motor feet holes are again centered on the motor mounting studs using the centering nut. At this point the centering nut is removed and replaced with a standard nut. This gives maximum potential mobility for the motor to be horizontally moved during the final, field alignment. All four motor feet are tightened down.
10. The pump and motor shafts are then aligned horizontally, both parallel and angular, by moving the pump to the fixed motor. The pump feet are tightened down.

11. Both horizontal and vertical alignment is again final checked as is the coupling spacer gap.
12. The nominal DBSE is 6 mm (0.25 in) longer than the coupling spacer length, facilitating installation and removal of the coupling spacer. Example: A pump/motor combination requiring a 178 mm (7.00 in) spacer coupling has a nominal DBSE of 184 mm (7.25 in)

NOTICE

13. See section 5.3.7 for Final Shaft Alignment

5.3 Installation

5.3.1 Pump and shaft alignment check

After connecting the piping (Section 5.3.7), rotate the pump drive shaft clockwise (viewed from motor end) by hand several complete revolutions to be sure there is no binding and that all parts are free. Recheck shaft alignment (Section 5.2.2). If piping caused unit to be out of alignment, correct piping to relieve strain on the pump.

5.3.2 Pump lubricants

5.3.2.1 Oil Bath: APE4 / OPE4

Oil bath is available on all product models. The standard bearing housing configuration is oil bath lubricated and is not lubricated by Flowserve. Before operating the pump, fill the bearing housing to the center of the oil sight glass with the proper type oil, when equipped sight glass or Watchdog oiler. (See Table 9: *Oil Sump Capacity* for approximate amount of oil required – do not overfill.)

The oil level in the bearing housing must be maintained at ± 3 mm ($\pm 1/8$ in) from the center of the sight glass. The sight glass has a 6 mm (1/4 in) hole in the center of its reflector. The bearing housing oil level must be within the circumference of the center hole to ensure adequate lubrication of the bearings.

NOTICE

The correct oil level can only be obtained when the pump is level in the longitudinal and transverse plans. Failure to level the pump may result in bearing damage and/or oil leakage. See Section 5 for levelling instructions.

To add oil to the housing, clean the area adjacent to and then remove the vent/breather [6521] at the top of the bearing housing, pour in oil until it is visually half way up in the sight glass [8221] or Watchdog oiler [3856] integral sight glass. Oil added to the bearing housing through vent location the falls directly on to the shaft. It takes several minutes for the oil level to rise to it final level after adding oil. To avoid overfilling the bearing housing, wait several minutes after the oil level has reached the bottom of the center hole in the sight glass reflector [8221]. Then, add additional oil slowly to raise the oil level to the center of the reflector. When not equipped with a sight glass, the correct oil level is obtained with the constant level oiler in its lowest position, which results in the oil level being at the top of the oil inlet pipe nipple, or half way up in the sight glass window. Oil must be visible in the bottle at all times.

See Table 10: *Recommended Oils* for recommended lubricants. **DO NOT USE DETERGENT OILS.** The oil must be free of water, sediment, resin, soaps, acid and fillers of any kind. It should contain rust oxidation inhibitors and anti-foam additives. The proper oil viscosity is determined by the bearing housing operating temperature as given in Table 12: *Oil Viscosity Grades*.

Note that on APE4 power ends there is no constant level oiler and no vent/breather (replaced by a plug). This is the ASME B73.1 compliant configuration and is preferred. As stated above, proper oil level is the center of the “bull’s eye” sight glass [8221]. Refer to Figure 22

NOTICE Only add oil when the pump has not operated for a least five minutes. Due to windage of the bearing housing oil, the observed oil level will appear to drop when the pump is running. This is normal operation. Do not add additional oil while the pump is running.

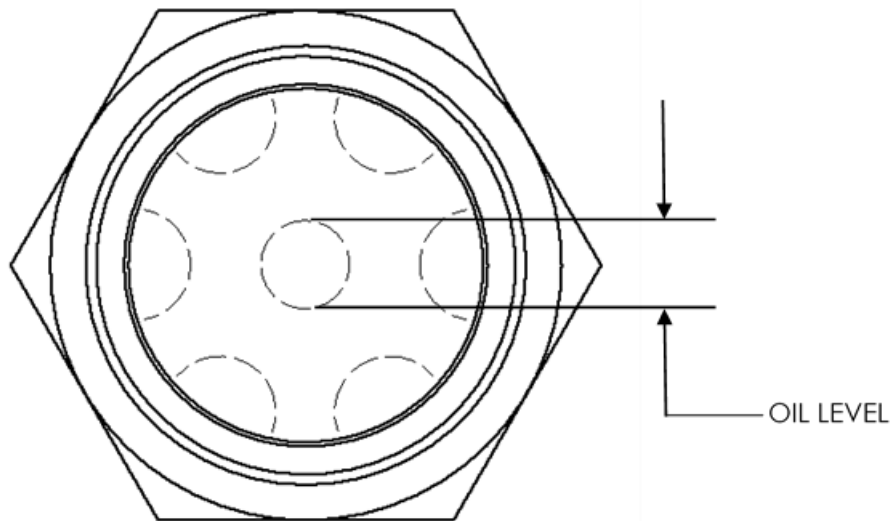

Figure 22: Sight Glass [8221]

In many pumping applications lubricating oil becomes contaminated before it loses its lubricating qualities or breaks down. For this reason, it is recommended that the first oil change take place after approximately 160 hours of operation, at which time, the used oil should be examined carefully for contaminants. During the initial operating period, monitor and record the oil temperature. See Table 12: *Oil Viscosity Grades* for maximum acceptable temperatures. Verify that the initial oil fill viscosity is appropriate for the previously recorded oil temperature. The normal oil change interval is based on temperature and is shown in Table 13: *Lubricant Intervals*.

Table 9: Oil Sump Capacity

Frame 41K	2500 ml (84.5 fl. oz.)
Frame 42K	2700 ml (91.3 fl. oz.)

Table 10: Recommended Oils

Centrifugal pump lubrication	Oil	Oil bath/ Purge oil mist/ pure oil mist lubrication		
	Viscosity cSt @ 40 °C	32	46	68
	Oil temperature range *	-5 to 58 °C (23 to 136 °F)	-5 to 70 °C (23 to 158 °F)	-5 to 80 °C (23 to 176 °F)
	Designation according to ISO 3448 and DIN51524 part 2	ISO VG 32 32 HLP	ISO VG 46 46 HLP	ISO VG 68 68 HLP
Oil companies and lubricants	BP Castrol †	Energol™ HLP-HM 32	Energol™ HLP-HM 46	Energol™ HLP-HM 68
	ESSO †	Nuto™ HP 32	Nuto™ HP 46	Nuto™ HP 68
	elf/TOTAL †	ELFOLNA DS 32 AZOLLA ZS 32	ELFOLNA DS 46 AZOLLA ZS 46	ELFOLNA DS 68 AZOLLA ZS 68
	LSC® (For oil mist) **	LSO 32 (Synthetic oil)	LSO 46 (Synthetic oil)	LSO 68 (Synthetic oil)
	Mobil †	Mobil DTE™ 24	Mobil DTE™ 25	Mobil DTE™ 26
	Q8 †	Q8 Haydn 32	Q8 Haydn 46	Q8 Haydn 68
	Shell †	Shell Tellus 32	Shell Tellus 46	Shell Tellus 68
	Chevron Texaco †	Rando® HD 32	Rando® HD 46	Rando® HD 68
	SRS Industrial Lubricants †	Wiolan HS 32	Wiolan HS 46	Wiolan HS 68
	Fuchs †	Renolin CL 32	Renolin CL 46	Renolin CL 68
	Royal Purple **	SYNFILM 32	SYNFILM 46	SYNFILM 68

(*) Note that it normally takes 4 hours for bearing temperature to stabilize and the final temperature will depend on the ambient, r/min, pumpage temperature and pump size. Also some oils have a greater viscosity index than the minimum acceptable of 95 (eg Mobil DTE 10 Excel™ Series) which may extend the minimum temperature capability of the oil. Always check the grade capability where the ambient is less than -5 °C (23 °F). An oil heater is recommended for temperatures below -12 °C (14 °F).

(†) Use LSC for oil mist. Oil parameters provide flash point >166 °C (331 °F), density >0.87 @ 15 °C (59 °F), pour point of -10 °C (14 °F) or lower.

(**) Normal compounded oils CANNOT be used with oil mist as anti-foam additives need to be avoided. Most oils recommended for wet splash lubrication contain foam inhibitors, as well as, antioxidants and anticorrosion additives, so they are unsuitable for oil mist. Some synthetic lubricants may attack the Nitrile seals when used in the bearing housing. The LSC LSO oils are recommended for oil mist applications. The APE4 and OPE4 power end are equipped with fluoroelastomers O-rings, for compatibility with synthetic lubricants.

Where the ambient temperature is very low, special lubricants are required. When oil lubrication is utilized and the ambient is less than -5 °C (23 °F), ensure the oil pour point is at least 15 °K (27 °F) below the lowest anticipated ambient temperature, and ensure the upper operating range of the oil is not exceeded. ISO VG 46 oil is generally selected for an initial lubrication schedule, when ambient temperatures are expected to be between 7 °C (45 °F) and 32 °C (90 °F).

Other drivers and gearboxes, if appropriate, should be lubricated in accordance with their manuals.

Table 11: Recommended Greases

General Purpose Grease	Mobil Polyrex™ EM (or compatible) Polyurea with mineral oil. Factory fill. 0.885g/ml
Food Grade	Klübersynth UH1 64-62. (NLGI 2) NSF H1 registered, complies with FDA 21 CFR § 178.3570, 0.920g/ml
Low Temp	Aeroshell 22 -60 to 38 °C (-76 to 100 °F), 0.868g/ml Aeroshell 7 -35 to 60 °C (-31 to 140 °F), 0.966g/ml

Note: Grease lubricated pumps and electric motors are supplied pre-greased.

Table 12: Oil Viscosity Grades

Maximum Oil Temperature	ISO Viscosity Grade	Minimum Viscosity Index
Up to 58 °C (136 °F)	32	95
Up to 70 °C (158 °F)	46	95
Up to 80 °C (176 °F)	68	95
Up to 90 °C (194 °F)	100	95

NOTICE The maximum temperature that the bearings can be exposed to is 105 °C (220 °F).

Table 13: Lubricant Intervals*

Lubricants	Under 60 °C (140 °F)***	60-70 °C (140-158 °F)***	71-80 °C (158-176 °F)***	80-90 °C (176-194 °F)***
Grease	12 months	6 months	3 months	1.5 months
Mineral oil	12 months	6 months	3 months	1.5 months
Synthetic oil**	24 months	18 months	18 months	18 months

(*) Assuming good maintenance and operation practices, and no contamination.

(**) May be increased to 36 months after initial oil change with APE4 power end.

(***) Bearing temperatures up to 16 °C (30 °F) higher than housing.

5.3.2.2 Re-greaseable: RPE4

Single shielded re-greaseable bearings

When the grease lubrication option is specified the bearing housing [3200] is equipped with, a single shielded inboard (radial) bearing [3011], outboard (thrust) bearing retainer [2530] with integral grease shield, oil return blocking pin [6810], grease fittings [3853.1 & .2] and an inboard (radial) bearing grease relief fitting [9220].

NOTICE

The orientation of the bearing shield, as shown in Figure 23

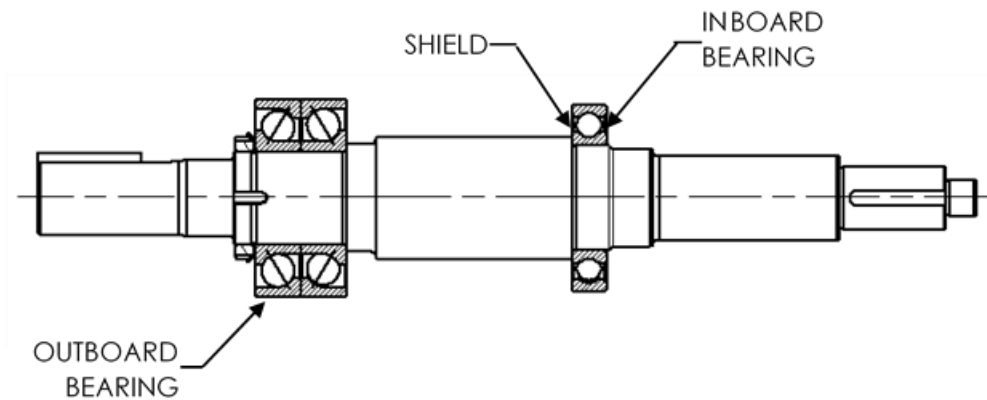

Figure 23: Bearing Shield Orientation

Pump bearings are packed with Mobil Polyrex™ EM grease prior to assembly. See Table 13: *Lubricant Intervals* for the recommend re-lubrication interval. For re-lubrication, a grease with the same type base (polyurea) and oil (mineral) should be used. To re-grease the radial bearing, add grease to the inboard grease fitting until grease exits the relief fitting on the opposite side of the bearing housing. To re-grease the thrust bearing, add the measured amount of grease specified in Table 14: *Grease Lubrication Amount*. Refer to Figure 24 for the grease fitting locations. After eight (8) re-lubrication intervals or three (3) years, it is recommended that the power end be disassembled and thoroughly cleaned, removing any used grease. See Section 8 for complete maintenance instructions.

NOTICE

Do not intermix greases shown in Table 11: *Recommended Greases*. They are not compatible.

Table 14: Grease Lubrication Amount**

Power End	Initial lube*	Re-lubrication
Frame 41K inboard	77g	24g
Frame 41K outboard	125g	66g
Frame 42K inboard	115g	31g
Frame 42K outboard	173g	82g

(*) If new bearings are not lubricated, they should be hand packed, approximately 70% of the open bearing volume, with the initial lube quantity prior to installation.

(**) Listed quantities are for Polyrex™EM with a density of 0.885g/ml. Grease quantity must be adjusted for the density of the grease applied. Multiply the ratio of {0.885/grease density} by the quantities listed to arrive at the required amount in grams.

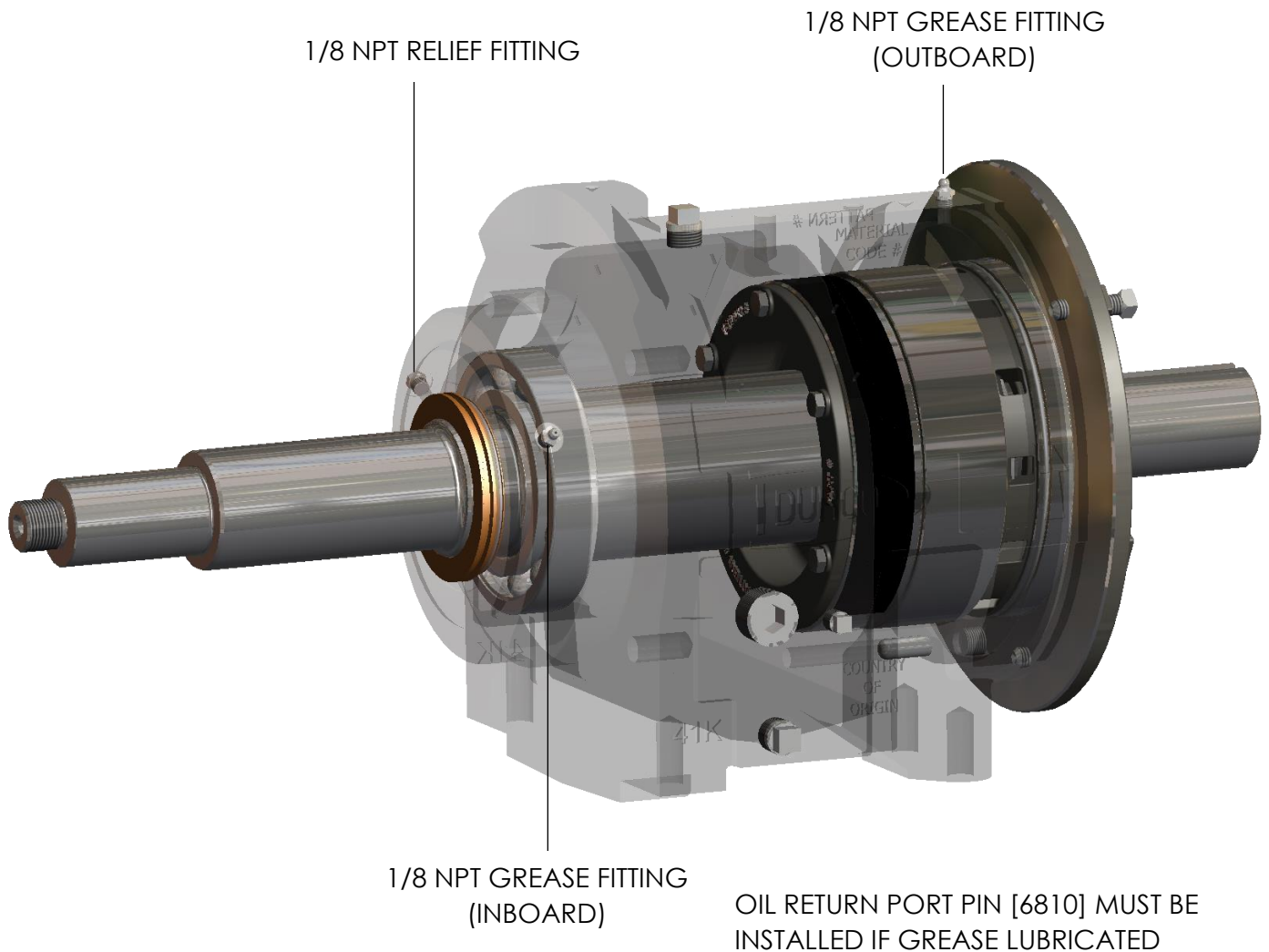

Figure 24: Re-greaseable Option

NOTICE Do not fill the housing with oil when greased bearings are used. The power end must be configured for oil; APE4 or OPE4 power end configuration required for oil.

NOTICE Do not convert the power end to grease lubrication without installing the grease return pin [6810] in the bearing housing [3200]. The inboard bearing [3011] must contain a shield. The bearing retainer [2530] functions as a shield for the outboard bearings [3013]. See Figure 34: RPE4 Power End Assembly

5.3.2.3 Grease for life

Grease for life option is not available with the Mark 3 Group 4 models.

5.3.2.4 Oil Mist: MPE4

To further limit dirt ingress and dew point issues within the bearing housing a ½ NPT. connection is available for a low-pressure instrument air or nitrogen supply where applicable.

The oil-mist fitting connections are located so that oil mist flows through the rolling element bearings to the sump. The thrust bearing inlet connection is a plugged 1/8 NPT port located on top of the rear most section of the bearing housing. The two radial bearing inlet connections are plugged 1/8 NPT ports located inside the adapter 25 degrees above horizontal. Either of the radial bearing connections can be used for the reclassifier connection. The unused connection must remain plugged. A plugged ½ NPT bottom drain is provided on the bearing housing. See section 3.5.3.4 for connection locations, *Oil mist lubrication system*. Do not allow oil level to remain above the center of the bearing housing sight glass window with purge mist (wet sump) systems. The thrust bearing oil return port must be closed with the Bearing Housing Pin [6810].

5.3.3 Impeller clearance

The impeller [2200] clearance was set at the factory. No further impeller adjustment should be necessary, see Table 15: *Impeller Clearance Setting*, unless the pump serviced. For reverse-vane impellers, the clearance is set to the cover [1220], while the semi-open impeller clearance is set to the casing [1100]. See section 8.8.3, for *Setting impeller clearance and impeller replacement*.

Table 15: Impeller Clearance Setting

Temperature °C (°F)	Clearance mm (in.)
-73 to 204 (-100 to 400)	0.81 (0.032)

Notes:

1. Rotation of bearing carrier from center of one lug to center of next results in axial shaft movement of 0.10 mm (0.004 in)
2. Set Reverse vane impeller clearance to cover, and semi-open impeller clearance to casing

5.3.4 Direction of rotation

All Mark 3 Group 4 pumps turn clockwise as viewed from the motor end. Direction arrows are cast in each side of the bearing housing [3200], as well as, the front and rear of the casing [1100], as shown in Figure 25. Bump the motor starter button without the pump connected to the motor. Verify that the motor rotates clockwise.

⚠ CAUTION It is essential that the rotation of the motor be checked before connecting the shaft coupling. Incorrect rotation of the pump, for even a short time, can dislodge and damage the impeller, casing, shaft and shaft seal.

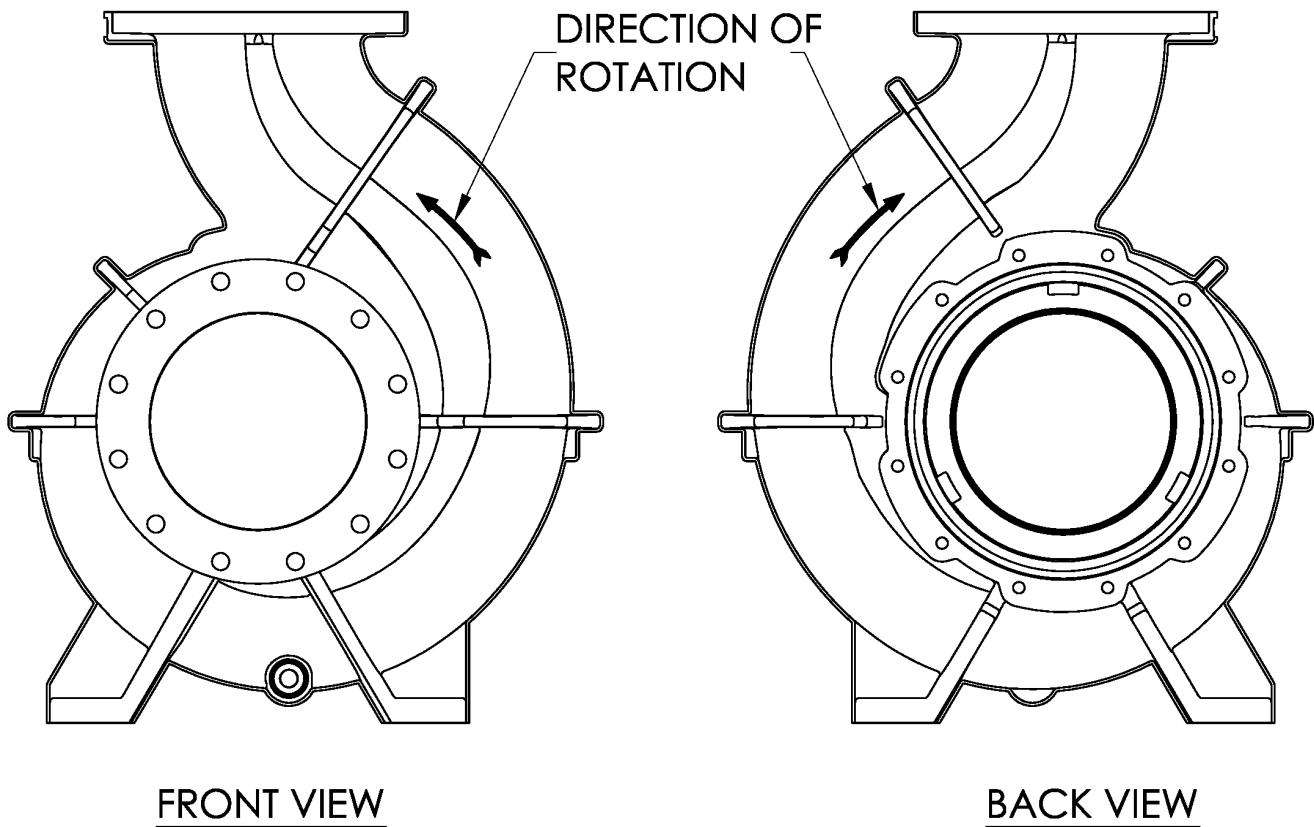

Figure 25: Direction of Rotation

5.3.5 Coupling installation

CAUTION The coupling (Figure 26) should be installed as advised by the coupling manufacturer. Pumps are shipped without the spacer installed. If the spacer has been installed to facilitate alignment, then it must be removed prior to checking rotation. Remove all protective material from the coupling and shaft before installing the coupling.

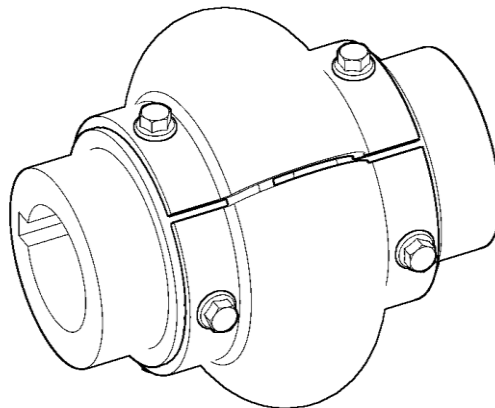

Figure 26: Coupling (typical)

5.3.6 Guarding

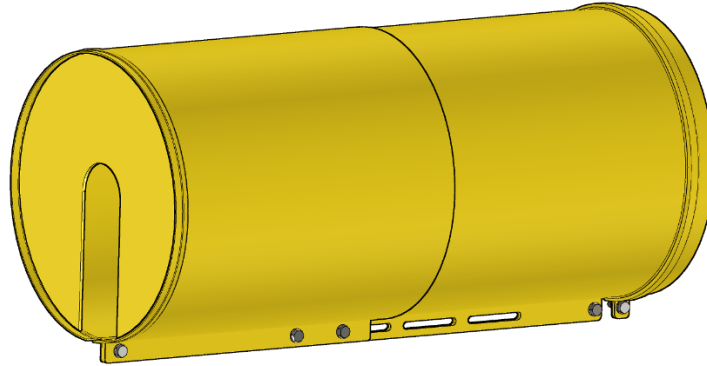

Figure 27: Assembled Guard

CAUTION

Power must never be applied to the driver when the coupling guard is not installed.

NOTICE

In member countries of the EU and EFTA, it is a legal requirement that fasteners for guards must remain captive in the guard to comply with the Machinery Directive 2006/42/EC. When releasing such guards, the fasteners must be unscrewed in an appropriate way to ensure that the fasteners remain captive.

Flowserve coupling guards are safety devices intended to protect workers from inherent dangers of the rotating pump shaft, motor shaft and coupling. It is intended to prevent entry of hands, fingers or other body parts into a point of hazard by reaching through, over, under or around the guard. No standard coupling guard provides complete protection from a disintegrating coupling. Flowserve cannot guarantee their guards will completely contain an exploding coupling.



Guarding is supplied and fitted to the pump set. If this has been removed or disturbed, ensure pump driver has been disconnected from its power supply.

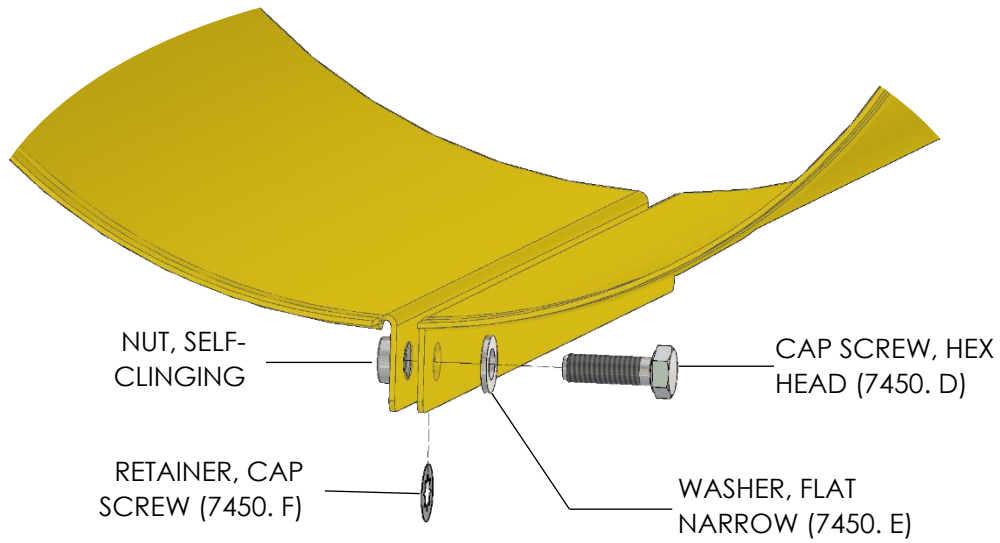
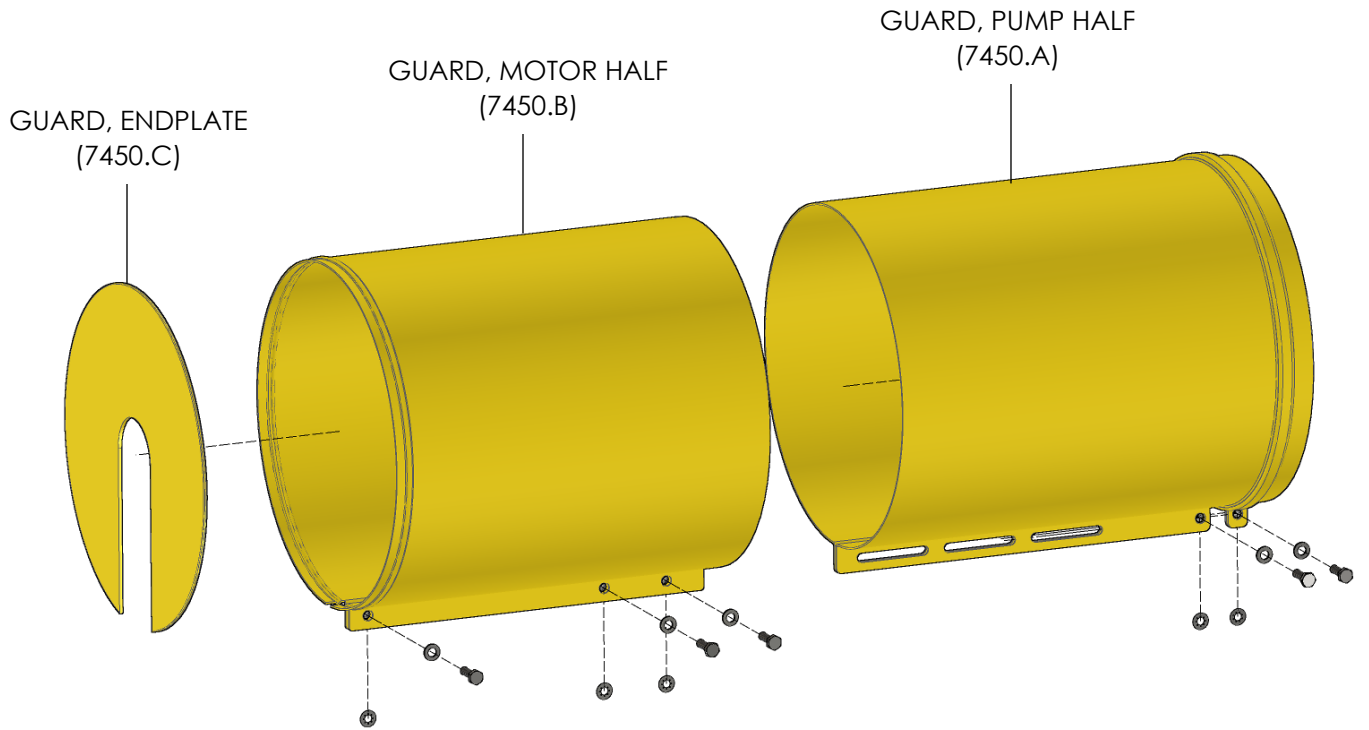

Figure 28: Guard Assembly

5.3.6.1 Removing coupling guard

Refer to Figure 28: Guard Assembly

1. De-energize the driver. Isolate from the power supply following your site's lockout-tagout (tag and lock) procedures.
2. Loosen all cap screws [7450. D] in the slotted holes in the center of the coupling guard. Cap screws should remain attached to the guard.
3. Slide the Motor Half [7450. B] towards the Pump Half [7450.A]
4. Remove the Endplate [7450. C], by slightly spreading the bottom of the Motor Half apart.
5. Remove the Motor Half, by slightly spreading the bottom apart and lifting upwards.
6. Remove the Pump Half from the bearing carrier [3240], by slightly spread the bottom apart and lifting upwards.

5.3.6.2 Installing coupling guard

Refer to Figure 28: Guard Assembly

1. De-energize the driver. Isolate from the power supply following your site's lockout-tagout (tag and lock) procedures.
2. Place Pump Half [7450.A] around bearing carrier [3240], by slightly spread bottom apart and placing over bearing carrier.
3. Loosely tighten the (2) cap screw [7450.D] in the Pump Half.
4. Place Motor Half [7450.B] around the Pump Half, by slightly spreading the bottom apart.
5. Place Endplate [7450.C] in the internal circumferential groove in the Motor Half.
6. Loosely tighten the (3) cap screw on the Motor Half.
7. Slide the assembled Motor Half towards the driver until it or the Endplate contacts the driver. If the driver is equipped with a bearing isolator, leave a distance of 6mm (0.25in) to the isolator rotor.
8. Once both halves of the guard are positioned correctly, tighten the (5) Cap Screws into the self-clinging nuts [7450.G]. Torque (5) Cap Screws to 12Nm (9 ft-lb).

5.3.7 Final shaft alignment check

1. Check and level the baseplate if needed. See 5.2.1 Mounting grouted baseplates
2. Mount and level pump, if not completed previously. Level the pump by putting a level on the discharge flange.
3. If not level, adjust the foot piece by adding or deleting shims [3126] between the foot piece [3143] and the bearing housing [3200].
4. Check initial alignment. If pump and driver have been remounted or the specifications given below are not met, perform an initial alignment as described in Section 5.2.2. This ensures there will be sufficient clearance between the motor hold down bolts and motor foot holes to move the motor into final alignment. The pump and driver should be within 0.38 mm (0.015 in) FIM (full indicator movement) parallel, and 0.0025 mm/mm (0.0025 in/in) FIM angular.

5. Run piping to the suction and discharge of the pump. There should be no piping loads transmitted to the pump after connection is made. Recheck the initial alignment to verify that there are no significant changes. If either the vertical or horizontal alignment changes more than 0.05 mm (0.002 in) after final torque of flange bolts, correct pipe strain before continuing to final alignment.
6. Perform final alignment. Check for soft-foot under the driver. Place a dial indicator base on the baseplate with the indicator in contact with the top on the motor foot. Then loosen the holding down bolt while noting any deflection reading on the Dial Test Indicator – a maximum of 0.05 mm (0.002 in) is considered acceptable, but any more will have to be corrected by adding shims, for example, if the dial indicator shows the foot lifting 0.15 mm (0.006 in) then this is the thickness of shim to be placed under that foot. Tighten down and repeat the same procedure on all other feet until all are within tolerance.
7. When satisfactory alignment is obtained the number of shims in the pack should be minimized. It is recommended that no more than five shims be used under any foot. Final horizontal alignment is made by moving the driver. Maximum pump reliability is obtained by having near perfect alignment. Flowserve recommends no more than 0.05 mm (0.002 in) TIR parallel, and 0.0005 mm/mm (0.0005 in/in) angular misalignment. It is recommended that the motor shaft is set 0.05 mm (0.002 in) below the pump shaft during cold alignment, to allow for vertical thermal growth of the motor. (See section 8.6.11, Installed pump)
8. Operate the pump for at least two hours or until it and the driver reaches final operating temperature. Shut the pump down and recheck alignment while the pump is hot. Piping thermal expansion and motor vertical growth may change the alignment. Realign pump as necessary.

5.3.8 Priming and auxiliary supplies

The Mark 3 Group 4 standard pump will not move liquid unless the pump is primed. A pump is said to be “primed” when the casing and the suction piping are completely filled with liquid. To prime open discharge valves a slight amount. This will allow any entrapped air to escape and will normally allow the pump to prime, if the suction source is above the pump. When the suction source is below the pump, close the discharge valve and open the suction valve. The pump requires manual venting to prime the pump with vacuum. Once the pump fills with liquid, isolate the vacuum source and start the pump.

When a condition exists where the suction pressure may drop below the pump’s suction capability (NPSHr), it is advisable to add a low-pressure control device to shut the pump down when the pressure drops below a predetermined minimum.

6 Commissioning

CAUTION

These operations must be carried out by fully qualified personnel.

Pre-commissioning procedure

Prior to starting the pump, it is essential that the following checks be made. These checks are all described in detail in Section 8, *Maintenance*.

1. Pump and motor properly secured to the baseplate
2. All fasteners tightened to the correct torque
3. Coupling guard in place and not rubbing
4. Rotation check, see Section 5.3.4, *Direction of rotation*. **This is essential**
5. Impeller clearance setting
6. Shaft seal properly installed
7. Seal support system operational
8. Bearing are lubricated
9. Bearing housing cooling system operational, if fitted
10. Support leg cooling for center line mounting option operational
11. Heating/cooling for jacketed casing/cover operational
12. Pump instrumentation is operational
13. Pump is primed, See Section 5.3.8, *Priming and auxiliary supplies*
14. Rotation of shaft by hand

As a final step in preparation for operation, it is important to rotate the shaft by hand to be certain that all rotating parts move freely, and that there are no foreign objects in the pump casing.

WARNING

Driver power must be isolated. Lockout-tagout required prior to checking for free rotation.

7 Operation

7.1 Start-up

1. Fully open the suction valve. The suction valve must remain open while the pump is operating. Any throttling or adjusting of flow must be done through the discharge valve. Partially closing the suction valve can create cavitation and related pump performance problems.

NOTICE Never operate pump with the suction valve partially or fully closed. Damage to the pump is likely.

⚠ WARNING Never operate pump with both the suction and discharge valves closed. This could cause an explosion.

2. If liquid supply is not above pump, prime pump. See Section 5.3.8, *Priming and auxiliary supplies*
3. All cooling, heating, and flush lines must be started and regulated.
4. Start the driver (typically, the electric motor).

NOTICE Always operate the pump above 400 rpm. Otherwise damage to the labyrinth seals will occur.

5. Slowly open the discharge valve until the desired flow is reached. Maintain capacity above the Minimum Continuous Stable Flow (MCSF) listed in Section 7.2.1

⚠ WARNING The discharge valve must be opened within a short interval after starting the driver. Failure to do so could cause a dangerous build-up of heat, and possibly an explosion. See section 7.2.2 *Minimum thermal flow*

7.2 Normal operation

7.2.1 Minimum Continuous Stable Flow (MCSF)

Minimum continuous stable flow (MCSF) is the lowest flow at which the pump can operate and still meet the bearing life, shaft deflection and bearing housing vibration limits documented in ASME B73.1. Pumps may be operated at lower flows, but it must be recognized that the pump may exceed one or more of these limits. For example, vibration may exceed the limit set by the ASME standard. The size of the pump, the energy absorbed, and the liquid pumped are some of the considerations in determining MCSF.

The minimum continuous stable flow (MCSF) is based on a percentage of the best efficiency point (BEP). Table 16: *Minimum Continuous Stable Flow* identifies the MCSF for each Mark 3 Group 4 pump models. **Do not operate the pump below the MCSF shown on the Hydraulic Datasheet.**

When operating on a VFD at speeds not listed, the MCSF is obtained by linearly interpolating between the speeds shown in Table: 16 *Minimum Continuous Stable Flow*.

Table 16: Minimum Continuous Stable Flow

Pump Size	60 Hz		50 Hz	
	RPM	Min. Flow (% of BEP)	RPM	Min. Flow (% of BEP)
41K8X4-19 OP	1780	48%	1480	21%
	1180	19%	980	21%
41K8X4-19 RV	1780	49%	1480	29%
	1180	30%	980	30%
41K8X6-19 OP	1780	15%	1480	13%
	1180	14%	980	29%
41K8X6-19 RV	1780	51%	1480	36%
	1180	38%	980	40%
41K10X6-19 OP	1780	52%	1480	47%
	1180	38%	980	49%
41K10X6-19 RV	1780	69%	1480	61%
	1180	24%	980	39%
41K12X10-19 OP	1180	49%	980	51%
	885	48%	740	60%
41K12X10-19 RV	1180	37%	980	38%
	885	34%	740	14%
42K12X8-22 OP	1180	62%	980	49%
	885	62%	740	70%
42K12X8-22 RV	1180	60%	980	25%
	885	25%	740	25%
42K12X10-22 OP	1180	65%	980	63%
	885	65%	740	70%
42K12X10-22 RV	1180	65%	980	14%
	885	19%	740	20%

7.2.2 Minimum thermal flow

All Mark 3 pumps also have a *minimum thermal flow*. This is defined as the minimum flow that will not cause an excessive temperature rise. Minimum thermal flow is application dependent.

⚠️ WARNING Do not operate the pump below minimum thermal flow, as this could cause an excessive temperature rise. Contact a Flowserve sales engineer for determination of minimum thermal flow, if you are not qualified to determine this value.

Avoid running a centrifugal pump at drastically reduced capacities or with discharge valve closed for extended periods of time. This can cause rapid temperature rise and the liquid in the pump may reach its boiling point. If this occurs, the mechanical seal will be exposed to vapor. The lack of fluid lubrication to the seal, may damage the seal faces. Continued running under these conditions when the suction valve is also closed can create an explosive condition due to the confined vapor at high pressure and temperature.

Thermostats may be used to safeguard against overheating by shutting down the pump at a predetermined temperature.

Safeguards should also be taken against possible operation with a closed discharge valve, such as installing a bypass back to the suction source. The size of the bypass line and the required bypass flow rate is a function of the input horsepower and the allowable temperature rise.

7.2.3 Reduced head

As the discharge valve is opened, discharge pressure will drop and capacity will increase. Power drawn by the pump will increase with the increase capacity. Increased motor temperature, is an indication of overload. A motor temperature above 60 °C (140 °F) is an indication of overload (consult motor manufacture for specific maximum temperature recommendations). If overloading occurs, throttle the discharge.

Reduced discharge is also an indication higher than normal flow. Cavitation and recirculation may occur, damaging the pump. If abnormal noise is heard, throttle the pumps.

7.2.4 Surging condition

A rapidly closing discharge or check valve can cause a damaging pressure surge (water hammer). A dampening arrangement should be provided in the piping.

⚠️ CAUTION Pressure rise due to water hammer can exceed the MDP (Maximum Design Pressure) for the pump. The mechanical seal, gaskets or casing can fail, causing a loss of the pumped liquid.

7.2.5 Operation in sub-freezing conditions

When using the pump in sub-freezing conditions where the pump is periodically idle, the pump should be properly drained or protected with thermal devices which will keep the liquid in the pump from freezing.

7.2.6 Performance and operation limits

This product has been selected to meet the specification of your purchase order. See section 2.1, Intended use. The data in the following sub-sections contains additional information to help with your installation. It is typical, and factors such as liquid being pumped, temperature, material of construction, and seal type may influence this data. If required, a definitive statement for your application can be obtained from Flowserve.

7.2.7 Alloy cross reference chart

Table 17: Alloy Cross-Reference

Flowserve Material code	Designation	Durco Legacy Codes	ACI Designation	Equivalent Wrought Designation	ASTM Specifications	Material Group No.
E3020	Ductile iron	DCI	None	None	A395, Gr. 60-40-18	1.0
C3009	Carbon steel	DS	None	Carbon steel	A216, Gr. WCB	1.1
C3062	Durco CF8	D2	CF8	304	A744, Gr. CF8	2.1
C3069	Durco CF3	D2L	CF3	304L	A744, Gr. CF3	2.3
C3063	Durco CF8M	D4	CF8M	316	A744, Gr. CF8M	2.2
C3067	Durco CF3M	D4L	CF3M	316L	A744, Gr. CF3M	2.3
C3107	Durcomet 100	CD4M	CD4MCuN	Ferralium®	A995, Gr. 1B	2.8
C4028	Durimet 20	D20	CN7M	Alloy 20	A744, Gr. CN7M	3.17
C4029	Durcomet 5	DV	None	None	None	2.2
K3005	Durco CY40	DINC	CY40	Inconel® 600	A494, Gr. CY40	3.5
K3007	Durco M35	DMM	M351	Monel® 400	A494, Gr. M35-1	3.4
K3008	Nickel	DNI	CZ100	Nickel 200	A494, Gr. CZ100	3.2
K4007	Chlorimet 2	DC2	N7M	Hastelloy® B	A494, Gr. N7M	3.7
K4008	Chlorimet 3	DC3	CW6M	Hastelloy® C	A494, Gr. CW6M	3.8

® Ferralium is a registered trademark of Langley Alloys.

® Hastelloy is a registered trademark of Haynes International, Inc.

® Inconel and Monel are registered trademarks of International Nickel Co. Inc.

7.2.8 Pressure-temperature ratings

The pressure-temperature (P-T) ratings for Mark 3 Group 4 pumps are shown in Table 18. Determine the appropriate casing "Material Group No." in Table 17: *Alloy Cross-Reference*. Interpolation may be used to find the pressure rating for a specific temperature.

Example:

The pressure temperature rating for a Mark 3 Group 4 pump with Class 150 flanges and CF8M construction at an operating temperature of 150 °C (140 °F) is found as Follows:

1. The correct pressure - temperature chart is Table 18: *P-T Rating for 150# Flanges*
2. From Table 17: *Alloy Cross-Reference*, the correct material group for CF8M (D4) is 2.2
3. From Table 18: *P-T Rating for 150# Flanges*, the pressure-temperature rating is 14.8 bar (215 psig)
 - a. Linearly interpolate between listed temperatures to determine P-T ratings at other temperatures.



The maximum discharge pressure must be less than or equal to the P-T rating. Discharge pressure may be approximated by adding the suction pressure and the differential head developed by the pump.

Table 18: P-T Rating for 150# Flanges

Temp °C	Material Group No.										
	1.0	1.1	2.1	2.2	2.8	3.2	3.4	3.5	3.7	3.8	3.17
	barg										
-73	-	-	19.0	19.0	20.0	12.7	15.9	20.0	20.0	20.0	15.9
-29	17.2	19.6	19.0	19.0	20.0	12.7	15.9	20.0	20.0	20.0	15.9
-18	17.2	19.6	19.0	19.0	20.0	12.7	15.9	20.0	20.0	20.0	15.9
38	17.2	19.6	19.0	19.0	20.0	12.7	15.9	20.0	20.0	20.0	15.9
50	17.0	19.2	18.3	18.4	19.5	12.7	15.4	19.5	19.5	19.5	15.4
100	16.0	17.7	15.7	16.2	17.7	12.7	13.8	17.7	17.7	17.7	13.5
150	14.8	15.8	14.2	14.8	15.8	12.7	12.9	15.8	15.8	15.8	12.3
200	13.9	13.8	13.2	13.7	13.8	12.7	12.5	13.8	13.8	13.8	11.3
Temp °F	Material Group No.										
	1.0	1.1	2.1	2.2	2.8	3.2	3.4	3.5	3.7	3.8	3.17
	psig										
-100	-	-	275	275	290	185	230	290	290	290	230
-20	250	285	275	275	290	185	230	290	290	290	230
0	250	285	275	275	290	185	230	290	290	290	230
100	250	285	275	275	290	185	230	290	290	290	230
200	235	260	230	235	260	185	200	260	260	260	200
300	215	230	205	215	230	185	190	230	230	230	180
400	200	200	190	195	200	185	180	200	200	200	160

7.2.9 Maximum suction pressure

The maximum suction pressure for Mark 3 Group 4 pumps with reverse-vane (RV) impeller is located in Table 19: *Maximum Suction Pressure (RV)*. Suction pressure is limited to the lower of the maximum suction pressure listed or the P-T rating determined in Section 7.2.8 *Pressure temperature ratings*. For semi-open (OP) impellers, suction pressure is only limited by the P-T rating.

Table 19: Maximum Suction Pressure (RV)

Pump Size	Max. Suction Pressure barg (psig)
41K12X10-16	5.7 (80)
41K14X14-16	16.9 (245)
41K8X4-19	6.4 (90)
41K8X6-19	7.5 (110)
41K10X6-19	8.2 (120)
41K12X10-19	15.4 (220)
41K14X12-19	16.0 (230)
42K10X8-19	9.4 (135)
42K16X16-19	16.4 (235)
42K12X8-22	12.8 (185)
42K12X10-22	13.3 (190)
42K14X12-22	13.8 (200)
42K16X14-22	6.2 (90)

Notes:

For suction pressure above 4 barg (60 psig) other factors may reduce the maximum allowable suction pressure. Refer to application specific Hydraulic Datasheet for details

7.3 Cleaning, disinfecting, and sterilizing

One of the major causes of pump failure is the presence of contaminants in the bearing housing. This contamination can be in the form of moisture, dust, dirt and other solid particles such as metal chips. Contamination can also be harmful to the mechanical seal (especially the seal faces) as well as other parts of the pump. For example, dirt in the impeller hub bore could cause the impeller to not be seated properly against the shaft. For these reasons, it is very important that proper cleanliness be maintained. Some guidelines are listed below.

- After draining the oil from the bearing housing, periodically send it out for analysis. If it is contaminated, determine the cause and correct.
- The work area should be clean and free from dust, dirt, oil, grease etc.
- Hands and gloves should be clean.
- Only clean towels, rags and tools should be used.

7.4 Shut-down

When the pump is being shut down, the procedure should be the reverse of the start-up procedure.

1. Slowly close the discharge valve
2. Shut down the driver
3. Close the suction valve



Closing the suction valve while the pump is running is a safety hazard and could seriously damage the pump and other equipment.

8 Maintenance, disassembly, inspection of parts, & assembly

8.1 Maintenance procedure

It is the plant operator's responsibility to ensure that all maintenance, inspection and assembly work is carried out by authorized and qualified personnel who have adequately familiarized themselves with the subject matter by studying this manual in detail. (See Section 2)



Any work on the machine must be performed when it is at a standstill and de-energized state. It is imperative that the procedure for shutting down the machine is followed, as described in Section 7.4, *Shut-down*.

Guard fasteners must remain captive during dismantling of guards, as described in Section 5.3.6, *Guarding*.

On completion of work all guards and safety devices must be re-installed and made operative again. Before restarting the machine, the relevant instruction listed in Section 6, Commissioning, must be observed.

Oil and grease leaks may make the ground slippery. Machine maintenance must always begin and finish by cleaning the ground and the exterior of the machine.

If platforms, stairs and guard rails are required for maintenance, they must be placed for easy access to areas where maintenance and inspection are to be carried out. The positioning of these accessories must not limit access or hinder lifting of the part to be serviced.

When air or compressed inert gas is used in the maintenance process, the operator and anyone in the vicinity must be careful and have the appropriate PPE, Personal Protective Equipment.

Do not spray air or compressed inert gas on skin

Do not direct an air or gas jet towards other people

Never use air or compressed inert gas to clean clothes

Never use air or compressed inert gas to spin bearings



Follow your company's lock-out tag-out procedures. If none exist perform the following steps:

Before working on the pump, take measures to prevent the pump from being accidentally started. Place a warning sign on the starter device:

“Machine under repair: do not start.”

With electric drive equipment, lock the main switch open and withdraw any fuses. Put a warning sign on the fuse box or main switch:

“Machine under repair: do not connect.”



Never clean equipment with flammable solvent or carbon tetrachloride. Protect yourself against toxic fumes when using cleaning agents, using appropriate PPE.

Refer to Table 22: *Parts List* shown in Section 8.5 for items number reference used throughout this section.

8.1.1 Preventive maintenance

The following sections of this manual give instructions on how to perform a complete maintenance overhaul. However, it is also important to periodically repeat the pre-commission procedures listed in Section 6. These checks will help extend pump life as well as the length of time between major overhauls.

8.1.2 Need for maintenance records

A procedure for keeping accurate maintenance records is critical part of any program to improve pump reliability. There are many variables that can contribute to pump failures. Often long term and repetitive problems can only be solved by analysing these variables through pump maintenance records.

8.2 Schedule

Table 20: Maintenance Schedule

Frequency	Task
Daily	<p>Check suction and discharge gauges</p> <p>Check for abnormal conditions (high/low temperature, flows, vibration, pressure etc.)</p> <p>Check motor current/driver power.</p> <p>Check for leakage from seals and joints.</p> <p>Check all lubricants levels (i.e. bearings housing oilers, seal plan 52/53, seal supply systems) (if applicable).</p> <p>Check for free flow of cooling medium (if applicable).</p> <p>Check stand-by pump is at applicable temperature and available to start as required.</p>
Weekly	<p>Check unit vibration</p> <p>Check operators log for loss of unit performance</p>
Monthly	<p>Check all lubricants for contaminations by sample analysis.</p> <p>Check all paint or protective coatings.</p> <p>Check all power/instrument cable glands for tightness</p>
Every Six Months	<p>Change all lubricants. See Table 13: <i>Lubrication Intervals</i> for specific recommendations.</p>
Yearly	<p>Check foundation fixing, bolting, grouting for looseness, cracking or general distress.</p> <p>Check unit alignment against previous inspections.</p> <p>Check calibration of instruments.</p>
Every Three Years	<p>Check internal conditions of pump and all auxiliary piping for corrosion/erosion.</p> <p>Check internal pump components for wear.</p>

NOTICE

This schedule is a recommendation only and is intended to be amended by site experience of the prevailing conditions. It outlines recommendations for the pump only and must be supplemented by schedules for other equipment on the package.

8.3 Special tools

A typical range of tools that will be required to maintain these pumps is listed below. SAE standard tools are required (standard inch).

- Hand wrenches
- Socket wrenches
- Allen wrenches
- Soft mallet
- Screwdrivers

Special equipment

- Bearing pullers
- Bearing induction heaters
- Dial indicators
- Spanner wrench
- Torque wrenches
- Flowserve Mark 3 Group 4 tool kit (see below)

To simplify maintenance, it is recommended that Flowserve Mark 3 Group 4 tool kit, as shown in Figure 29, is used. This tool kit includes a handy impeller wrench, which simplifies installation and removal of the impeller. It also contains “nose cones” which protect shaft threads and O-rings during maintenance. This tool kit can be ordered from your local Flowserve sales engineer or from a Flowserve distributor or representative.



Figure 29: Mark 3 Group 4 tool kit

8.4 Required replacement parts for maintenance

- Mechanical process fluid seals
- Bearing housing seals
- Bearings
- Shaft or shaft sleeve
- Impeller
- Gaskets / O-rings

8.5 Disassembly

Table 21: Torque Requirements

Item	Location & Description		Frame 41K		Frame 42K	
			Nominal size	Fasteners Nm (ft-lb)	Nominal size	Fasteners Nm (ft-lb)
2912	Impeller	Nut ¹	1.250-12 UNF	380 (280)	1.375-12 UNF	530 (390)
6570.1	Bearing Retainer	Screw	.375-16 UNC	18 (13)	.375-16 UNC	18 (13)
6570.4	Bearing Housing Foot	Cap Screw	.750-10 UNC	150 (110)	.750-10 UNC	150 (110)
6570.5	Adapter	Screw	.750-10 UNC	150 (110)	.750-10 UNC	150 (110)
6570.6	Cap Screw – 16"	Token Bolt	.500-13 UNC	43 (32)	N/A	N/A
6570.6	Cap Screw – 19"	Token Bolt	.625-11 UNC	86 (64)	.625-11 UNC	86 (64)
6570.6	Cap Screw – 22"	Token Bolt	N/A	N/A	.625-11 UNC	86 (64)
6570.8	IPS Beacon™ 2	Button Head	.25-28 UNF	8.5 (6.3)	.25-28 UNF	8.5 (6.3)
6580.1	Casing – 16"	Nuts	.750-10 UNC	110 (79)***	N/A	N/A
6572.1	Impeller	Studs				
6580.1	Casing – 19"	Nuts	.875-9 UNC	170 (130)***	.875-9 UNC	170 (130)***
6572.1	Impeller	Studs				
6580.1	Casing – 22"	Nuts	N/A	N/A	.875-9 UNC	170 (130)***
6572.1	Impeller	Studs				
6580.2	Gland*	Nuts	.625-11 UNC	54 (40)	.625-11 UNC	54 (40)
6572.2		Studs				
6580.2	Mechanical Seal** Gland with O-ring	Nuts	.625-11 UNC	68 (50)	.625-11 UNC	68 (50)
6572.2		Studs				
6814	Bearing Carrier	Set Screw	.500-13 UNC	37 (27)	.500-13 UNC	37 (27)
6541.1	Shaft	Locknut	AN 16	267 - 273 (197 - 275)	AN 18	336 - 508 (248 - 375)
-	Foot to Baseplate	Cap Screw	.750-10 UNC	150 (110)	.750-10 UNC	150 (110)
-	Casing to Baseplate	Cap Screw	.750-10 UNC	150 (110)	.875-9 UNC	250 (190)

Note:

1. Use Nickel Anti-Seize lubricant on the impeller nut thread.
 2. Unless noted values shown are for non-lubricated / non-coated threads.
 3. Gasket joints torque values are for unfilled PTFE gaskets. Other gaskets materials may require additional torque to seal. Exceeding metal joint torque values is not recommended.
 4. Use only AS
 5. A193 studs and A194 nuts. This is a requirement for pressure retaining fastener per ASTM Boiler Pressure Vessel Code BPVC. Studs ends must be stamped with the ASTM A193 Grade designation. Examples: B7, B8, B8M, B7TF. Grade B8C1 is only suitable for packing gland studs.
- * Use the values shown if the torque value is not supplied by the seal manufacture.
- ** These values apply to factory supplied Flowserve ISC2 Series seals only. For all other seals follow the manufacture's recommendations.
- *** These values apply to B8, B8M, and B7TF studs. If needed to seal the joint, B7FT stud torque can be increased up to 20%, and B8 stud torque can be increased up to 10%.

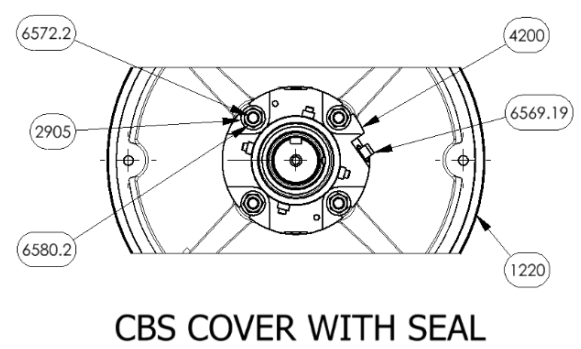
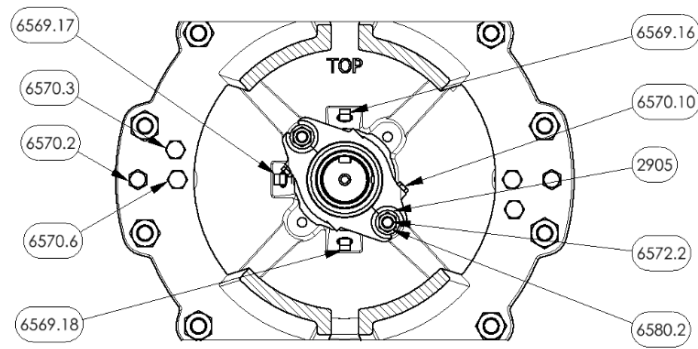
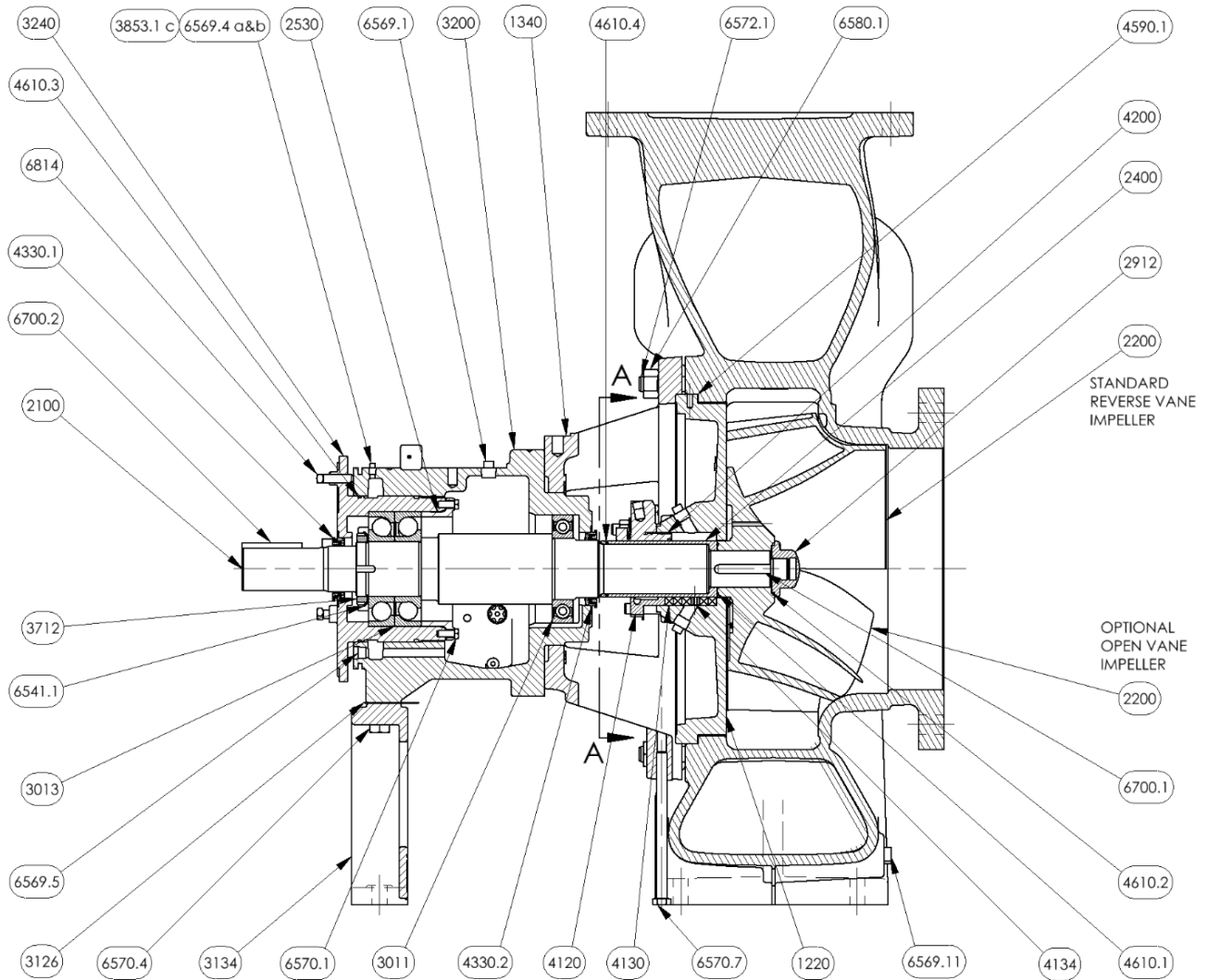

**SECTION A-A
CBS COVER WITH PACKING**

CBS COVER WITH SEAL

Figure 30: Sectional of pump with APE4 & CBS cover

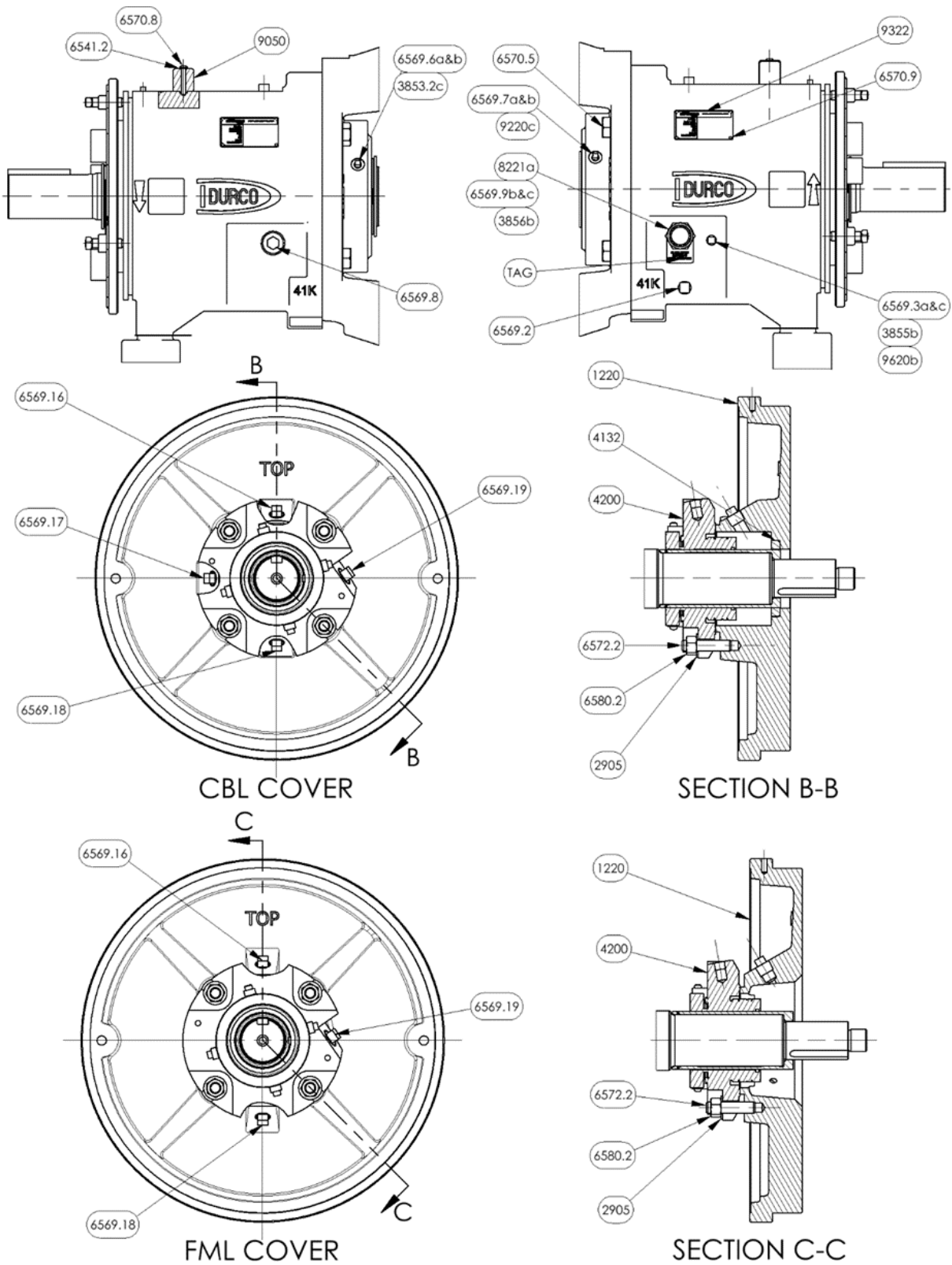

Figure 31: Sectional of APE4 bearing housing, CBL & FML Covers

Table 22: Parts List

ITEM	TITLE	ITEM	TITLE
1100	Casing	6569.2	Plug- Drain (magnetic) ^a
1220	Casing Cover	6569.3	Plug – Oiler Tap ^{a/c/d}
1340	Adapter	6569.4	Plug – Thrust bearing ^{a/b/d}
2100	Shaft	6569.5	Plug – Thrust Bearing Drain Port
2200	Impeller RV/OP	6569.6	Plug – Radial Bearing (right) ^{a/b/d}
2400	Shaft Sleeve	6569.7	Plug – Radial Bearing (left) ^{a/b/d}
2530	Retaining Ring (oil) ^{a/b/d}	6569.8	Plug – Sight Glass (right)
2530	Retaining Ring (grease) ^{NS/c}	6569.9	Plug – Sight Glass (left) ^{NS/b/c/d}
2905	Plain Washer	6569.11	Plug – Casing Drain (optional)
2912	Impeller Nut	6569.12	Plug – Casing Suction (optional) ^{NS}
3011	Radial Bearing w/o shield ^{a/b/d}	6569.13	Plug – Casing Discharge (optional) ^{NS}
3011	Radial Bearing with shield ^{NS/c}	6569.16	Plug – Cover Seal Chamber (optional-FML)
3013	Thrust Bearing	6569.17	Plug – Cover Seal Chamber, Flush (optional)
3126	Shim - Foot	6569.18	Plug – Cover Seal Chamber, Bottom (optional)
3134	Foot – Bearing housing	6569.19	Plug – Mechanical Seal
3200	Bearing housing	6570.1	Cap Screw – Bearing Retainer
3240	Bearing carrier	6570.2	Cap Screw – Jack Bolts, Casing
3712	Locknut - Shaft	6570.3	Cap Screw – Jack Bolts, Cover
3853.1	Grease Fitting – Thrust Bearing ^{NS/c}	6570.4	Cap Screw – Bearing Housing Foot
3853.2	Grease Fitting – Radial Bearing ^{NS/c}	6570.5	Cap Screw – Adapter
3855	Oiler Opto-Matic ^{NS/b}	6570.6	Cap Screw – Token Bolt
3856	Oiler Watchdog ^{NS/b}	6570.7	Cap Screw – Adapter Support
4120	Gland Packing	6570.8	Button Socket Cap Screw – Beacon (optional)
4130	Packing	6570.9	Driver Screw – Nameplate
4132	Throat Bushing	6570.10	Cap Screw – Split Gland
4134	Lantern Ring - Packing	6572.1	Stud – Casing
4200	Mechanical Seal	6572.2	Stud – Gland
4330.1	Bearing Isolator (outboard)	6580.1	Nut – Casing
4330.2	Bearing Isolator (inboard)	6580.2	Nut – Gland
4590.1	Gasket – Casing / Cover	6700.1	Key – Impeller
4610.1	O-Ring – Impeller	6700.2	Key – Coupling
4610.2	O-Ring – Impeller Nut	6810	Pin – Bearing Housing ^{NS/c/d}
4610.3	O-Ring – Bearing Carrier	6814	Set Screw – Bearing Carrier
4610.4	O-Ring – Sleeve	8221	Gauge – Sight Glass ^a
6521	Breather ^{NS/b}	9050	IPS Beacon™ 2 (optional)
6541.1	Lock Washer – Shaft	9322	Nameplate
6541.2	Lock Washer – Beacon (optional)	9220	Relief Fitting ^{NS/c}
6569.1	Plug – Vent ^{a/c/d}	9620	Nipple ^{NS/b}
6569.2	Plug – Drain ^{b/c}	TAG	Tag – Oil Level ^{a/b}

Note: The following subscripts also apply for Figures: 30 and 31 Only
 APE4 power end is shown in sectionals
 a = APE4 power end b = OPE4 power end c = RPE4 power end d = MPE4 power end NS = Not Shown in Sectionals

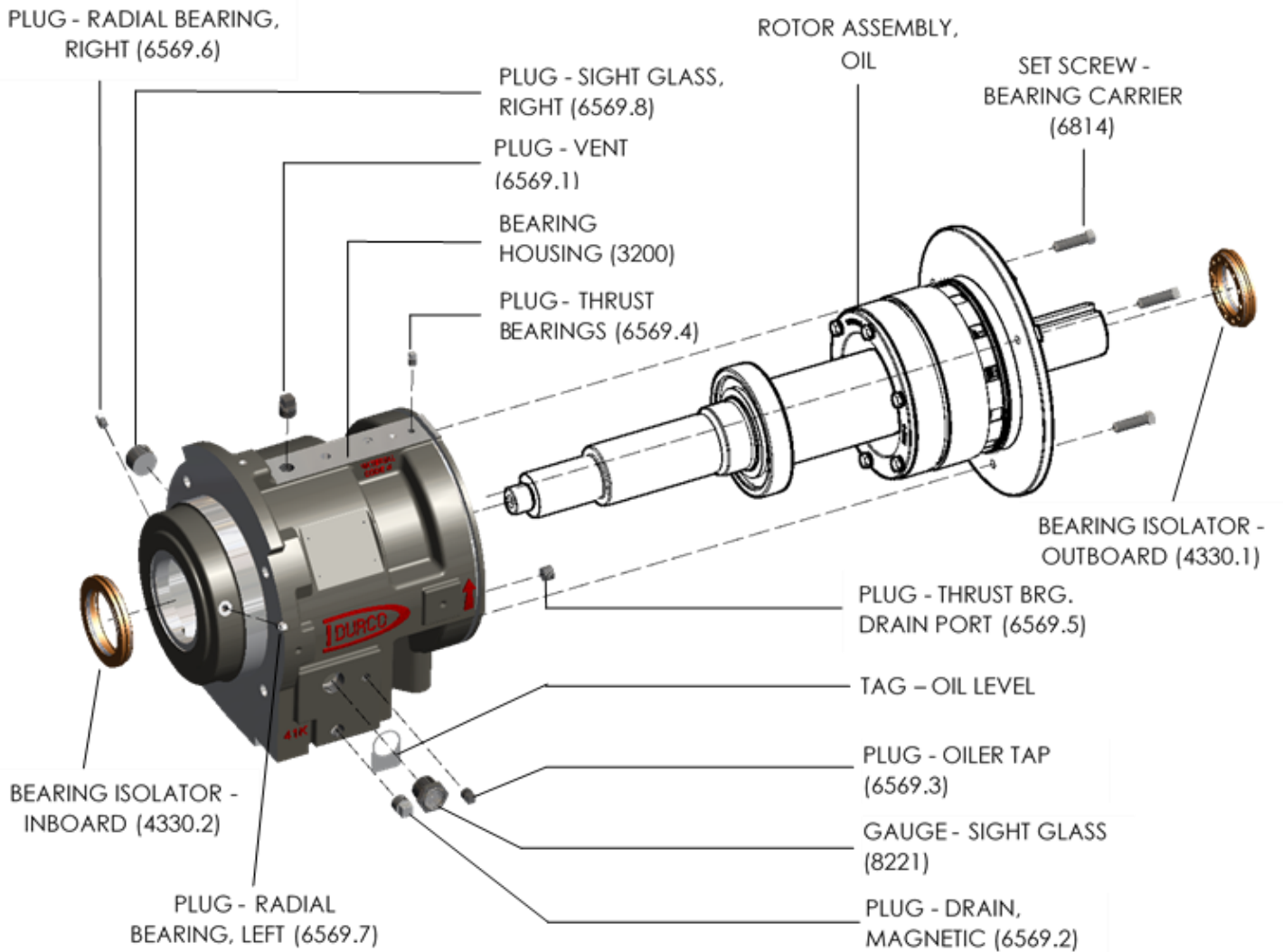

Figure 32: APE4 Power End

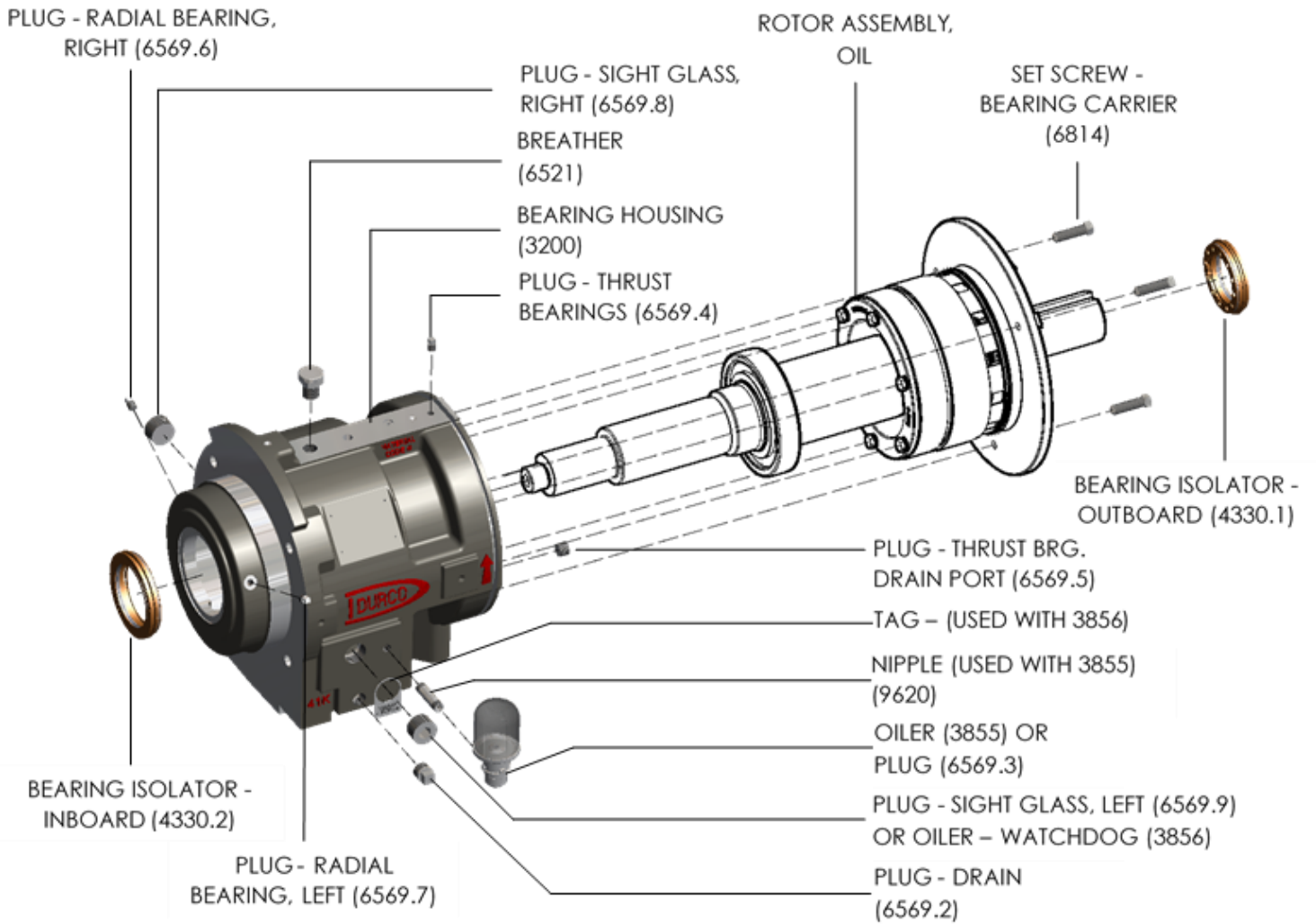

Figure 33: OPE4 Power End Assembly

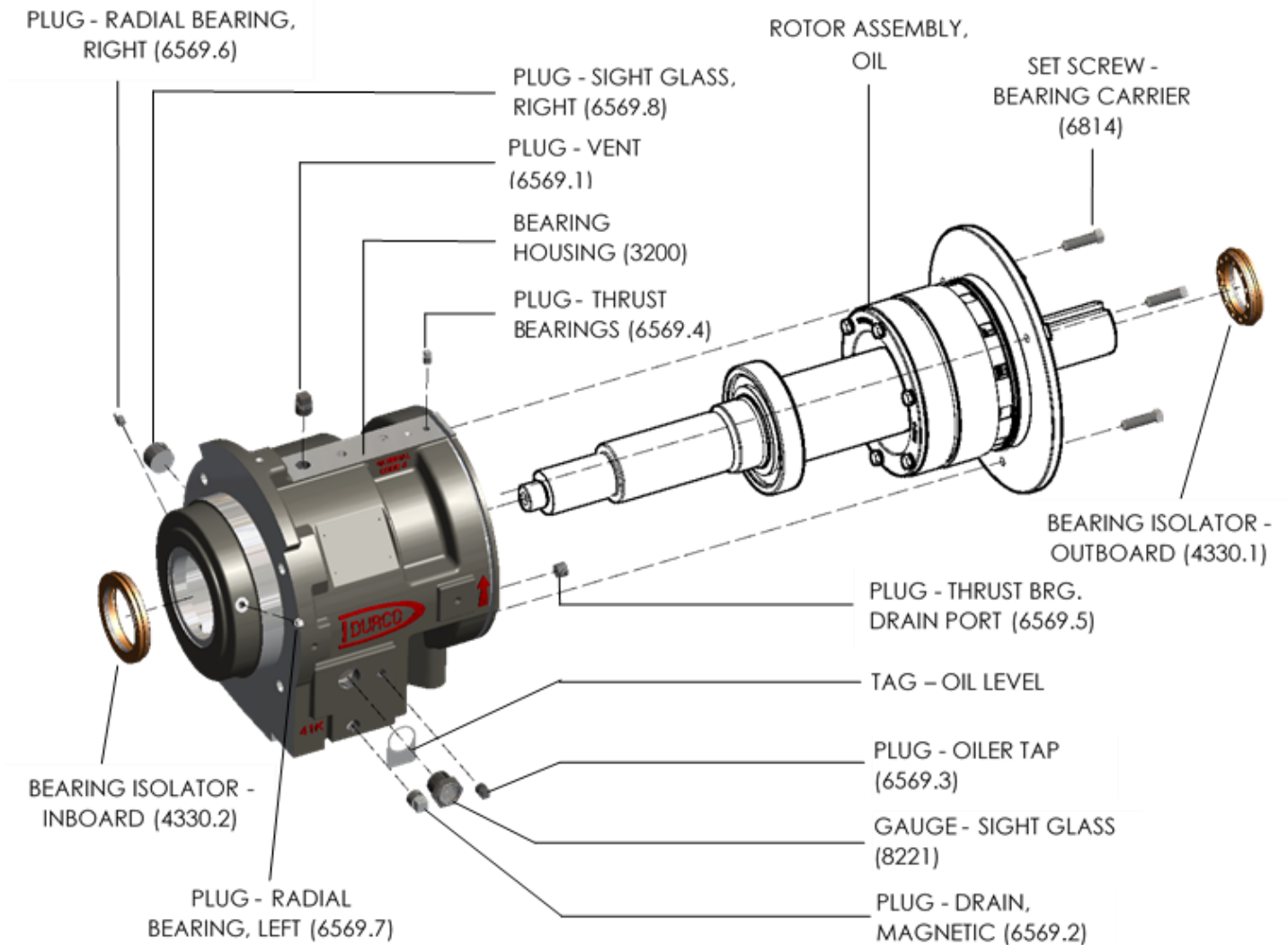

Figure 34: RPE4 Power End Assembly

CAUTION

The power end / rear cover assembly is heavy, as are the individual components. Follow the lifting procedure found in Section 4, *Transportation*, when moving, disassembling or assembling the pump. Always follow facility safety guidelines when lifting.

8.5.1 Power end removal

1. Before performing any maintenance, lock-out and tag-out driver.

⚠ CAUTION

Lock out power to driver to prevent personal injury.

2. Close the discharge and suction valves, and drain all the liquid from the pump.
3. Close all valves on auxiliary equipment and piping, then disconnect all auxiliary piping.
4. Decontaminate the pump as necessary.

⚠ WARNING

If the pumps contain dangerous chemicals, it is important to follow plant safety guidelines to avoid personal injury or death.

5. Remove the coupling guard. (see Section 5.3.6)
6. Remove the spacer from the coupling.
7. Remove casing fasteners [6580.1].
8. Remove the fasteners holding the bearing housing foot to the baseplate.
9. Move the (back pullout assembly) power end, rear cover, impeller and seal chamber assembly away from the casing. Discard the casing/cover gasket [4590.1]
10. Install the adapter support screw [6570.7].
11. Transport the assembly to maintenance shop.

8.5.2 Pump disassembly

1. Remove the coupling hub from the pump shaft [2100].
2. If oil or oil mist lubricated, remove drain plug [6569.2] from the bearing housing [3200] to drain oil. Recycle or disposed of using local environmental regulation methods.
3. Bolt or clamp the bearing housing foot [3134] securely to a heavy work table. Using the coupling key [6700.2], mount the impeller wrench from the Flowserve Mark 3 tool kit (Figure 29) to the end of the shaft, as shown in Figure 51: Removing Impeller. With the impeller wrench handle pointing to the left when viewed from the impeller end, with an impact wrench, loosen the impeller nut [2913], turning counter-clockwise.
4. Carefully remove impeller. Mark 3 Group 4 impellers weight up to 77 kg (170 lb). Secure the impeller, as shown in Figure 13: Lifting Impeller. Remove the impeller key [6700.1]
5. Discard the impeller and impeller nut O-rings [4610.1] and [4610.2].

⚠ CAUTION

Do not apply heat to the impeller. If liquid is entrapped in the hub, an explosion could occur.

7. If equipped with a cartridge type mechanical seal [4200], reinstall the seal setting clips or tabs, per the seal manufacturer's instructions. This will ensure that the proper seal compression is maintained.
8. Remove the seal or packing gland nuts [6580.2] and washers [2905], if so equipped.
9. If a component type outside mechanical seal is used, loosen the set screws on the rotating unit and remove it from the shaft. Remove the gland and the stationary seat. Remove the stationary seat from the gland. Discard all O-rings and gaskets.
10. If a cartridge type inside mechanical seal [4200] is used, loosen the set screws on the rotating unit and remove it from the shaft, see Figure 49: FML Cover with Cartridge Seal. Then pull the

gland [4120] and stationary seat off the shaft. Remove the stationary seat from the gland. Discard all O-rings and gaskets.

11. If a component type inside mechanical seal is used, remove the gland and the stationary seat. Remove the stationary seat from the gland. Loosen the set screws in the rotating unit and remove it from the shaft. Discard all O-rings and gaskets.
12. If packing [4130] is used, remove it and the seal cage [lantern ring, 4134], using a packing puller.
13. To remove the cover, first secure with a long shank lifting eye, as shown in Figure 12: Lifting Cover. Remove the two token bolt screws [6570.6], that attach the Cover [1220] to the adapter. Carefully remove lift and remove the cover.
14. If packing is used, remove the packing gland [4120]
15. If the pump has a hook type sleeve [2400] it can now be removed. Discard the sleeve O-ring [4610.4]

NOTICE

Do not pry against the shaft.

16. Loosen the (3) three set screws [6814] on the bearing carrier [3240]. The bearing carrier must be completely unscrewed from the bearing housing. The face of the bearing carrier has three square lugs that protrude from the surface. Turn the bearing carrier [3240] counter-clockwise, using an open-end wrench on one of the rectangular lugs.
17. The carrier O-ring [4610.3], radial bearing [3011] fit in the bearing housing [3200], and the inboard bearing isolator [4330.2] O-rings on the shaft [2100] will cause some resistance in removing the bearing carrier assembly from the housing. Temporarily, screw the impeller nut [2912] on to the shaft hand tight. A slight impact, with a soft mallet, on the impeller nut, will free the bearing carrier assembly with the shaft and bearings, see Figure 44: Rotor Assembly - Oil. Further disassembly is not required unless the bearings are to be replaced, or cleaned (grease lubrication).

CAUTION

The rotor assembly weight up to 80 kg (176 lb). Use appropriate lifting equipment.

18. Remove the (6) bearing retainer – cap screws [6570.1] and bearing retainer [2530]. Remove the carrier [3240] from the thrust bearing [3013].
19. One tab on the lock-washer will be engaged in the locknut. Bend the tab on the lock-washer [6541.1] away from the locknut [3712]. The bearing locknut and lock-washer may now be removed from the shaft [2100]. Discard the lock-washer.
20. An arbor or hydraulic press may be used to remove the bearings [3011] and [3013] from the shaft. It is extremely important to apply even pressure to the inner bearing race only. Never apply pressure to the outer race as this exerts excess load on the balls and causes damage.

CAUTION

Applying pressure to the outer race could will damage the bearing. And, the outer bearing race to separate from the balls and inner race.

21. On the adapter [1340] side of the bearing housing [3200], remove the plugs [6569.6 & 7] or grease fitting [3853.2] and [9220] from the bearing housing.
22. The bearing housing [3200] must be separated from the adapter [1340]. This is accomplished by removing the (4) cap screws [6570.5], which thread into the bearing housing.
23. If the bearing isolators [4330] are removed from either the bearing carrier or bearing housing they must not be reused, discard appropriately. The isolator rotor O-rings should be replaced, if reusing the isolators.
24. If magnetic seals are used, maintain the seals as specified by manufacturer.

25. Remove Oiler and/or sight glass

a) OPE4 design

- Remove the Trico Watchdog oiler/sight glass [3856] or Opti-Matic oiler [3855] and oil level tag, if equipped, from the bearing housing. See Figures 35 and 36.

b) APE4 design

- Remove the sight glass [8221] and oil level tag from the bearing housing. See Figures 35 and 36.

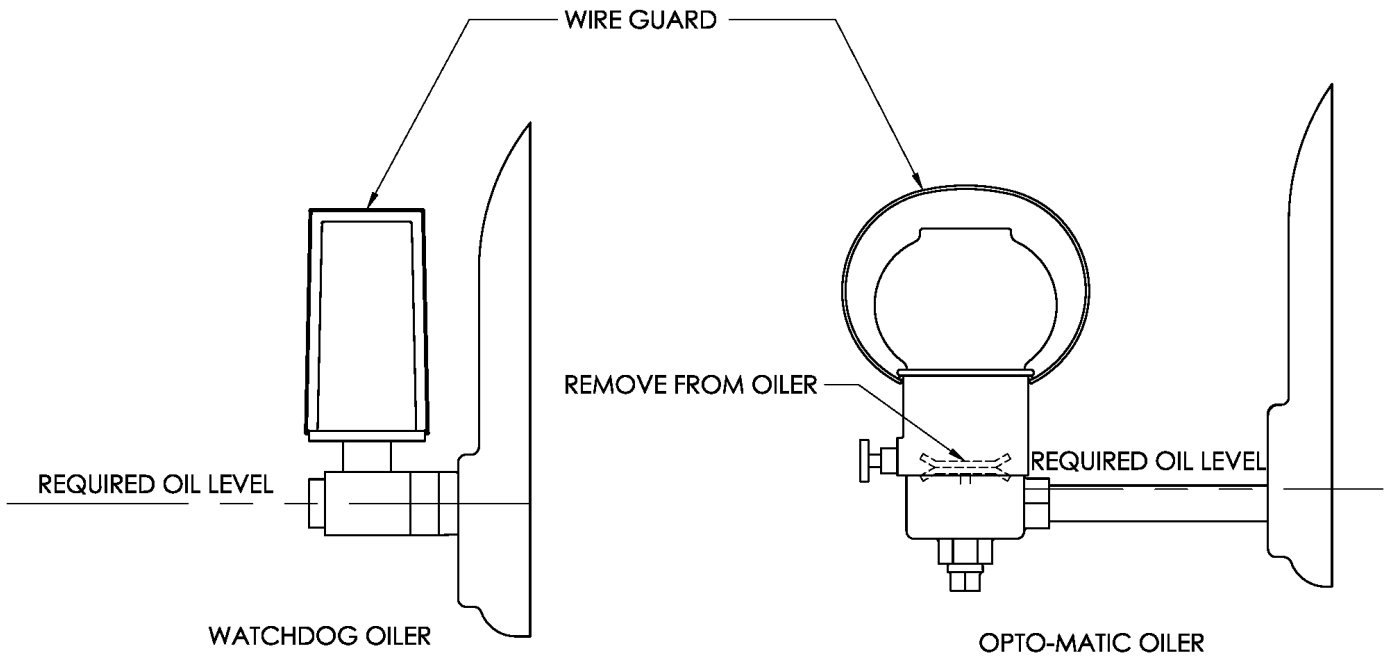

Figure 35: Oilers options



Figure 36: Oil Level Tag

8.6 Inspection of parts

8.6.1 Cleaning/inspection

All parts should now be thoroughly cleaned and inspected. New bearings, O-rings, gaskets, and lip seals should be used. Any parts that show wear or corrosion should be replaced with new genuine Flowserve parts.

⚠ CAUTION It is important that only non-flammable, non-contaminated cleaning fluids are used. These fluids must comply with plant safety and environmental guidelines.

8.6.2 Critical measurements and tolerances

To maximize reliability of pumps, it is important that certain parameters and dimensions are measured and maintained within specified tolerances. It is important that all parts be checked. Any parts that do not conform to the specifications should be replaced with new Flowserve parts. All geometrical and dimensional values contained in this document are at a standard reference temperature of 20 °C (68 °F). See ISO 1:2016

8.6.3 Parameters that should be checked by users

Flowserve recommends that the user check the measurements and tolerance in Table 23: *Measurements & Tolerances* whenever pump maintenance is performed. Each of these measurements is described in more detail on the following pages.

8.6.4 Additional parameters checked by Flowserve

The parameters listed below are somewhat more difficult to measure and/or may require specialized equipment. For this reason, they are not typically checked by our customers, although they are monitored by Flowserve during the manufacturing and/or design process.

8.6.5 Shaft and sleeve (if fitted)

Replace if grooved, pitted or worn. Prior to mounting bearings or installing the shaft into the bearings housing, check the following parameters.

8.6.5.1 Diameter/tolerance, under bearings

To ensure proper fit between the shaft and bearings, verify that both the inboard (IB) and outboard (OB) shaft diameter is consistently within the minimum/maximum values shown in table 24: *Bearing Fits*. A micrometer should be used to check these outside diameters (O.D.) dimensions on the shaft.

8.6.6 Bearings

It is recommended that bearings not be re-used after removal from the shaft. Prior to mounting bearings, check the following parameters.

8.6.6.1 Diameter/tolerance, inside diameters

In order to ensure proper fit between bearings and the shaft, verify that the inside diameter (I.D.) of both the IB and OB bearings are consistently within the minimum/maximum values shown in Table 24: *Bearing Fits*. A bore gauge should be used to check I.D. of the bearings.

8.6.6.2 Diameter/tolerance, outside diameters

To ensure proper fit between bearings and the bearing housing, verify that the outside diameter (O.D.) on both the IB and OB bearings are consistently within the minimum/maximum values shown in Table 24: *Bearing Fits*. A micrometer should be used to check the O.D. on the bearings.

8.6.7 Impeller balancing

Shaft whip is deflection where the centerline of the impeller is moving around the true axis of the pump. It is not caused by hydraulic force but rather by a mass imbalance within the rotating element. Shaft whip shortens the life of mechanical seals, because the rotating face must move with each shaft revolution in order to maintain contact. To minimize shaft whip it is imperative that the impeller is balanced. All impellers manufactured by Flowserve are balanced after they are trimmed. If for any reason, a customer trims an impeller, it must be re-balanced. See note 1 under Table 23: *Measurements and tolerances* regarding acceptance criteria.

8.6.8 Bearing housing/carrier

Prior to installing the shaft into the bearing housing, check the following parameters.

8.6.8.1 Diameter/tolerance, at bearing surface

To ensure proper fit between the bearing housing/carrier and the bearings, verify that the inside diameter (I.D.) of both the IB and OB bearings surfaces are consistently within the minimum/maximum values shown in Table 23: *Measurements & Tolerances*. An inside micrometer or bore gauge should be used to check I.D. dimensions in the bearings housing.

Table 23: Measurements & Tolerances

Topic	ASME B73.1 Standard mm (in.)	Suggested by major seal vendor mm (in.)	Suggested and/or provided by Flowserve mm (in.)
Shaft Journals Diameter tolerance, under bearings	N/S	-	0.013 (0.0005)
Impeller Balance	ISO 21940-11 G6.3	-	ISO 21940-11 G6.3
Bearing Housing Journals Inside diameter, tolerance at bearings	N/S	-	0.02 (0.001)
Power end assembly Shaft runout (See note 4) Shaft sleeve runout Radial Deflection – static Shaft End Play	0.05 (0.002) 0.05 (0.002) N/S N/S	0.03 (0.001) 0.05 (0.002) 0.08 (0.003) 0.05 (0.002)	0.03 (0.001) 0.05 (0.002) 0.05 (0.002) 0.00 (0.000)
Seal Chamber Face squareness to shaft Register concentricity	0.08 (0.003) 0.13 (0.005)	0.03 (0.001) 0.13 (0.005)	0.08 (0.003) 0.13 (0.005)
Complete pump Shaft movement caused by pipe strain Alignment Vibration at bearing housing	N/S N/S See note 3	0.05 (.002) - -	0.05 (0.002) See note 2 See note 3

Notes:

N/S = not specified.

1. The maximum values of acceptable unbalance are:
 - a) 1500 r/min: 40 g•mm/kg (1800 r/min: 0.021 oz-in/lb) of mass.
 - b) 2900 rpm: 20 g•mm/kg (3600) rpm: 0.011 oz-in/lb) of mass.
 - c) Flowserve performs a two-plane dynamic balance, as required by the ASME B73.1 standard. All balancing is performed to the ISO 21940-11 Grade 6.3 tolerance criteria.
2. The ASME B73.1 standard does not specify a recommended level of alignment. Flowserve recommends that the pump and motor shafts be aligned to within 0.05 mm (0.002 in.) parallel FIM (full indicator movement) and 0.0005 mm/mm (0.0005 in./in.) angular FIM. Closer alignment will extend MTBPM. For a detailed discussion of this subject see the alignment section of this manual.
3. The ASME B73.1, Paragraph 7.1.4
4. The ASME B73.1, Paragraph 5.5.3

Table 24: Bearing Fits

Bearing to Shaft			Bearing to Carrier		
OB Brg./Shaft mm (in.)	Frame 41K	Frame 42K	OB Brg./Carrier mm (in.)	Frame 41K	Frame 42K
Bearing	79.985/80.000 (3.1490/3.1496)	89.985/90.000 (3.5427/3.5433)	Bearing	169.982/170.000 (6.6922/6.6929)	189.979/190.000 (7.4795/7.4803)
Shaft	80.002/80.015 (3.1497/3.1502)	90.005/90.018 (3.5435/3.5440)	Shaft	80.002/80.015 (6.6935/6.6945)	190.015/190.043 (7.4809/7.4820)
Fit	0.003 T-0.030 T (0.0001 T-0.0012 T)	0.003 T-0.033 T (0.0001 T-0.0013 T)	Fit	0.015 L-0.058 L (0.0006 L-0.0023 L)	0.015 L-0.064 L (0.0006 L-0.0025 L)
IB Brg./Shaft mm (in.)	Frame 41K	Frame 42K	IB Brg./Carrier mm (in.)	Frame 41K	Frame 42K
Bearing	89.985/90.000 (3.5427/3.5433)	99.985/100.000 (3.9364/3.9370)	Bearing	159.982/160.000 (6.2985/6.2992)	179.979/180.000 (7.0858/7.0866)
Shaft	90.005/90.018 (3.5435/3.5440)	100.002/100.018 (3.9371/3.9377)	Shaft	160.015/160.040 (6.2998/6.3008)	180.015/180.043 (7.0872/7.0883)
Fit	0.003 T-0.033 T (0.0001 T-0.0013 T)	0.003 T-0.033 T (0.0001 T-0.0013 T)	Fit	0.015 L-0.058 L (0.0006 L-0.0023 L)	0.015 L-0.064 L (0.0006 L-0.0025 L)

Note: All geometrical and dimensional values contained in this document are at a standard reference temperature of 20 °C (68 °F). See ISO 1:2016

T = Interference fit
L = Loose fit

8.6.9 Power end inspection

Perform the follow checked to the assembled bearing housing, carrier, bearings, shaft, seals and adapter.

8.6.9.1 Shaft/shaft sleeve runout

Shaft runout is the amount the shaft is “out of true” when rotated in the pump. It is measured by attaching a dial indicator to a stationary part of the pump so that its contact point indicates the radial movement of the shaft surface as the shaft is rotated slowly. If a shaft sleeve is used, then shaft sleeve runout must be checked. It is analogous to shaft runout. Measurement of shaft runout/shaft sleeve runout will disclose any out of roundness of the shaft, any eccentricity between the shaft and the sleeve, any permanent bend in the shaft, and/or any eccentricity in the way the shaft or bearings are mounted in the bearing housing.

Excessive shaft runout can shorten the life of the bearings and the mechanical seal. The following diagrams show how to measure shaft/shaft sleeve runout. Note that both ends need to be checked. The runout should be 0.05 mm (0.002 in.) FIM or less at the gland end of the seal chamber.

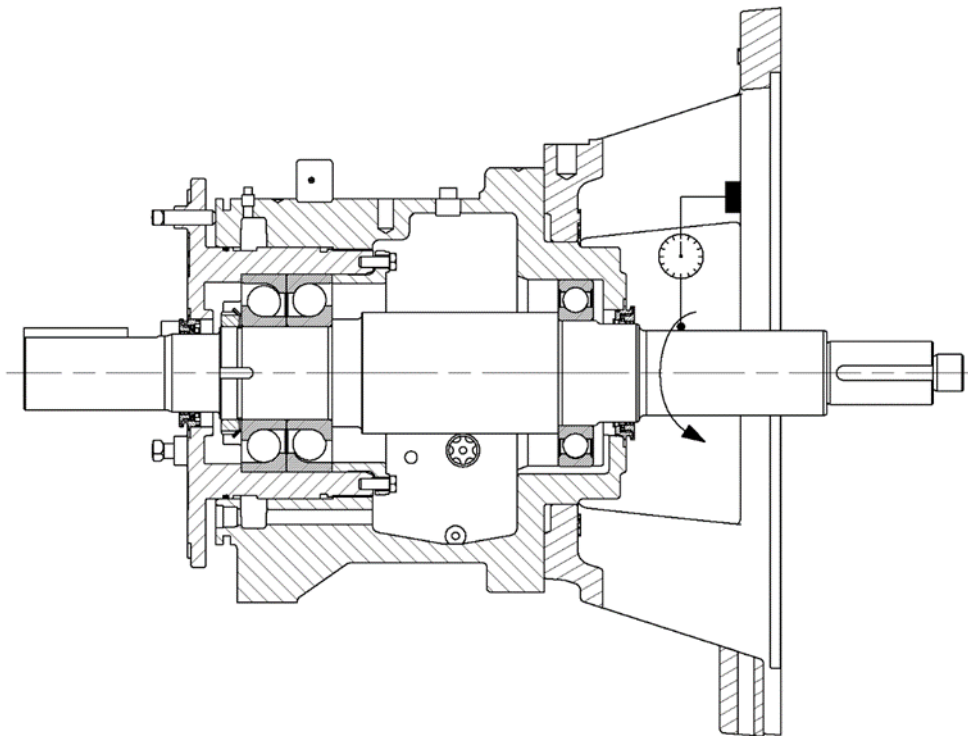

Figure 37: Runout

8.6.9.2 Radial deflection – static

Radial movement of the shaft can be caused by a loose fit between the shaft and the bearing and/or the bearing and the housing. Tighten bearing the (3) three bearing carrier set screws [6814] to the torque value shown in Table 21: *Torque Requirements*. Movement is measured by attempting to displace the shaft vertically by applying an upward force of approximately 9.1 kg (20 lb) to the impeller end of the shaft. While applying this force, indicator movement is observed, as shown in Figure 38. Check movement at a point as near as possible to the location of the seal faces. A movement of more than 0.05 mm (0.002 in.) is not acceptable.

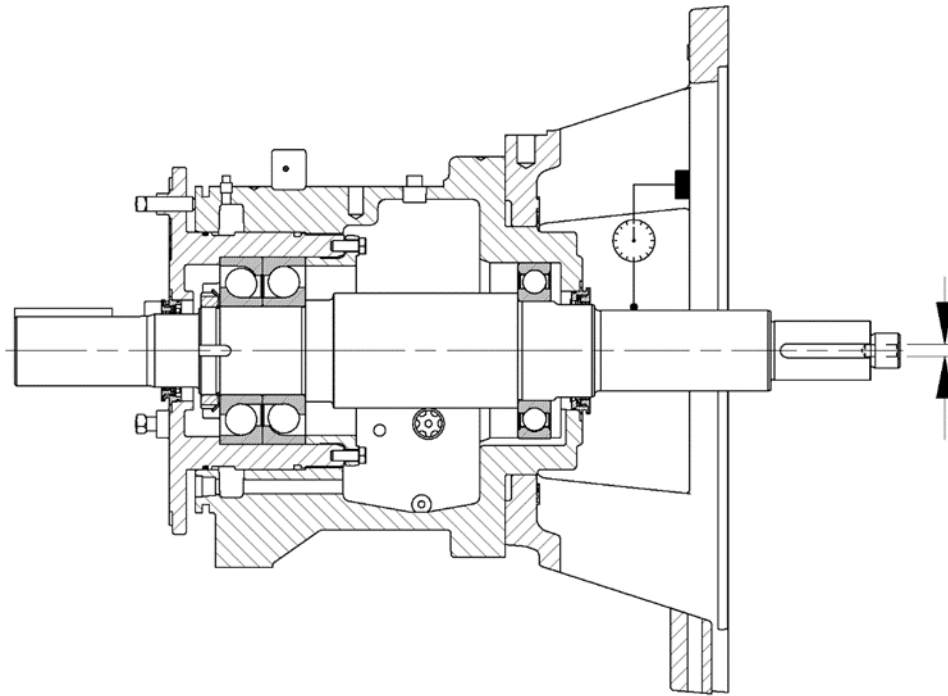

Figure 38: Radial Deflection

8.6.9.3 Shaft endplay

The maximum amount of axial shaft movement, or endplay, on a Mark 3 Group 4 pump should be 0.013 mm (0.0005 in.) With the bearing carrier set screws [6814] tighten to the torque value shown in Table 21: *Torque Requirements*, and standard BEGAY designation thrust bearings installed, endplay is measured, as shown in Figure 39. Observe indicator movement while lightly impacting the shaft from each end in turn with a soft mallet. Shaft endplay can cause several problems. It can cause fretting or wear at the point of contact between the shaft and the secondary sealing element. It can also cause seal overloading or under loading and possibly chipping of the seal faces. It can also cause the faces to separate if significant axial vibration occurs.

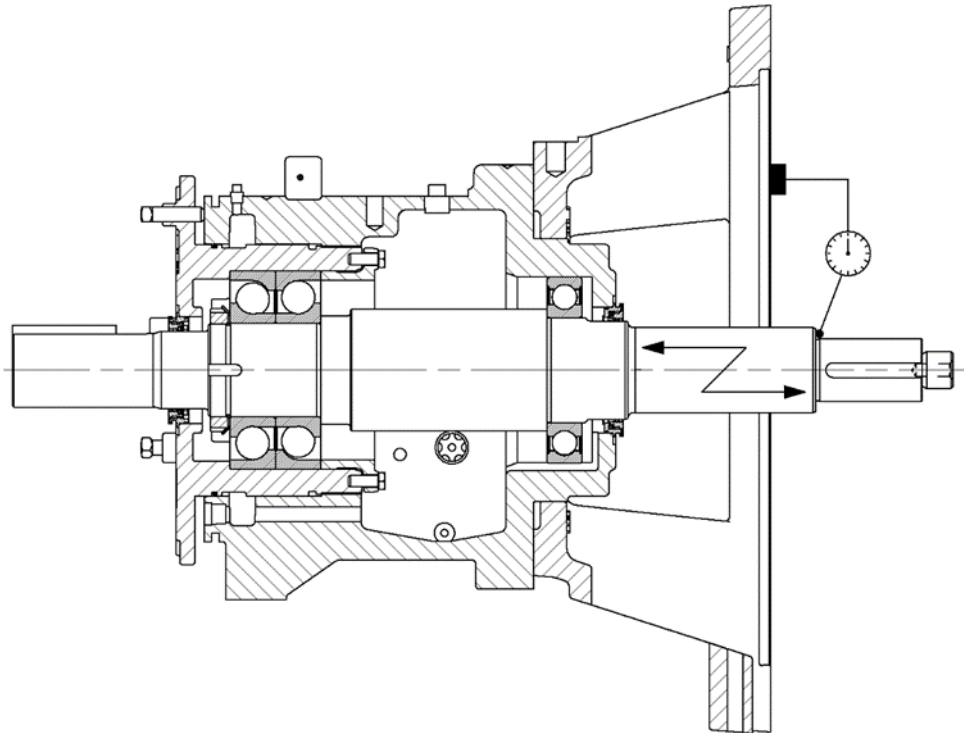

Figure 39: Endplay

8.6.10 Seal chamber inspection

Perform the following checks with the assembled power end and rear cover.

8.6.10.1 Seal chamber face perpendicularity to shaft

Also referred to as "Seal Chamber Face Runout." This runout occurs when the seal chamber face is not perpendicular to the shaft axis. This will locate the gland askew in relation to the shaft axis, which causes the stationary seat to be cocked, resulting in excess seal rotor movement, wear and a possible leak. This runout should be less than 0.08 mm (0.003 in.) FIM and should be measured, as shown in Figure 40.

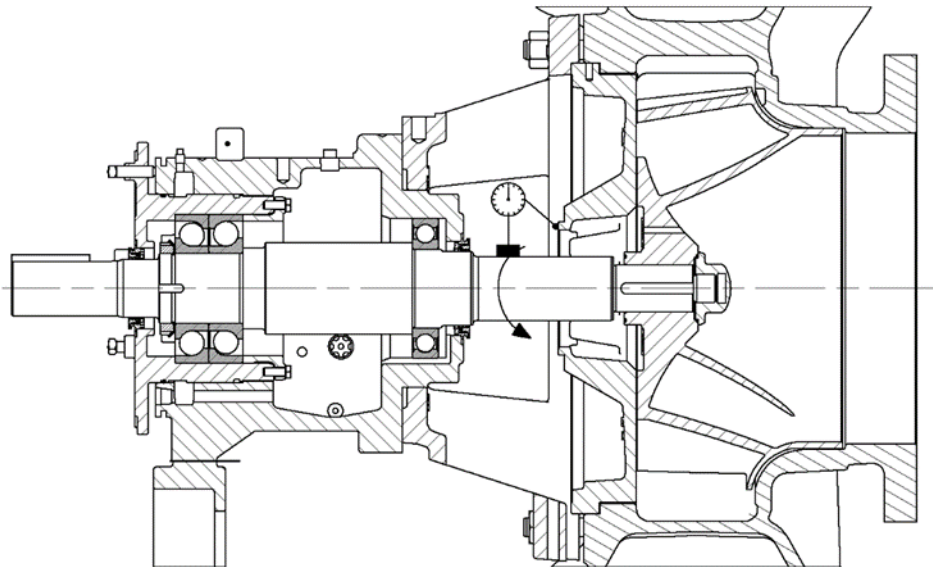

Figure 40: Face Perpendicularity

8.6.10.2 Seal Chamber register concentricity

An eccentric seal chamber bore or gland register can interfere with the piloting and centering of the seal components and alter the hydraulic loading of the seal faces, resulting in reduction of seal life and performance. The seal chamber register concentricity with the shaft or sleeve should be less than 0.13 mm (0.005 in.) TIR. The diagram below shows how to measure this concentricity.

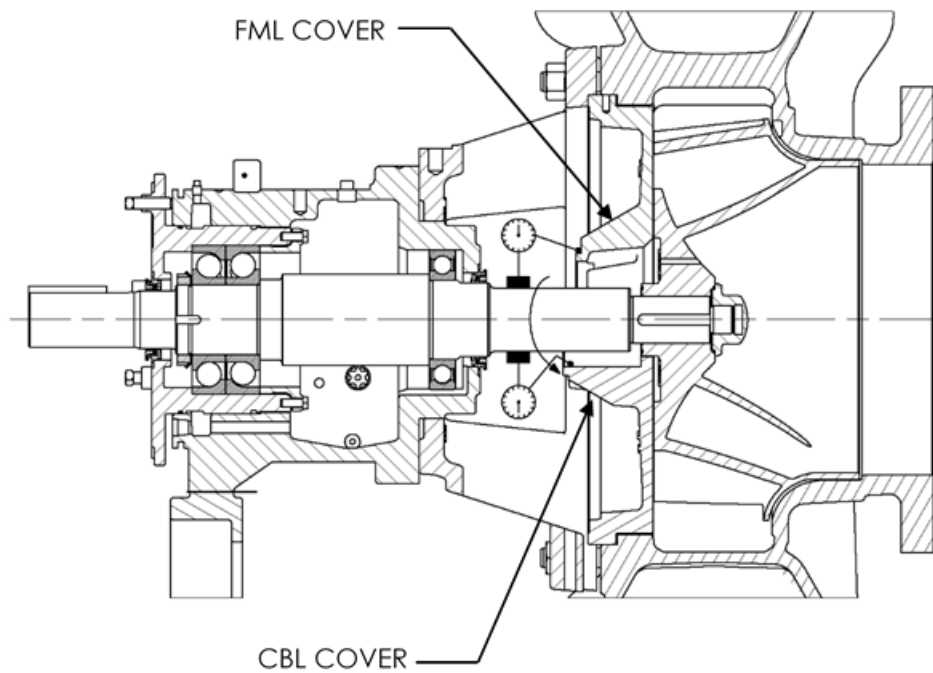

Figure 41: Concentricity

8.6.11 Installed pump: complete pump installed

The following must be checked during the installation and initial run-in of the pump.

8.6.11.1 Shaft movement caused by pipe strain

Pipe strain is excessive force put on the pump casing by the piping. Pipe strain should be measured, as shown in Figure 42. Install dial indicators or laser equipment as shown before attaching the piping to the pump. The flanges should now be bolted to the piping separately, starting with the suction. Continuously observed the indicators for movement. Tighten the flange bolts in steps. First to 10% of total torque, 30%, 60% and then 100% of total final torque. The maximum shaft movement in either direction, after final tightening, is 0.05 mm (0.002 in.). If the movement exceeds 0.05 mm (0.002 in.), loosen the flange bolts, make corrections to the piping or supports. Replace the flange gaskets and repeat the procedure. If multiple pumps are attached to common suction or discharge piping, piping strain is to be checked simultaneously on all pumps.

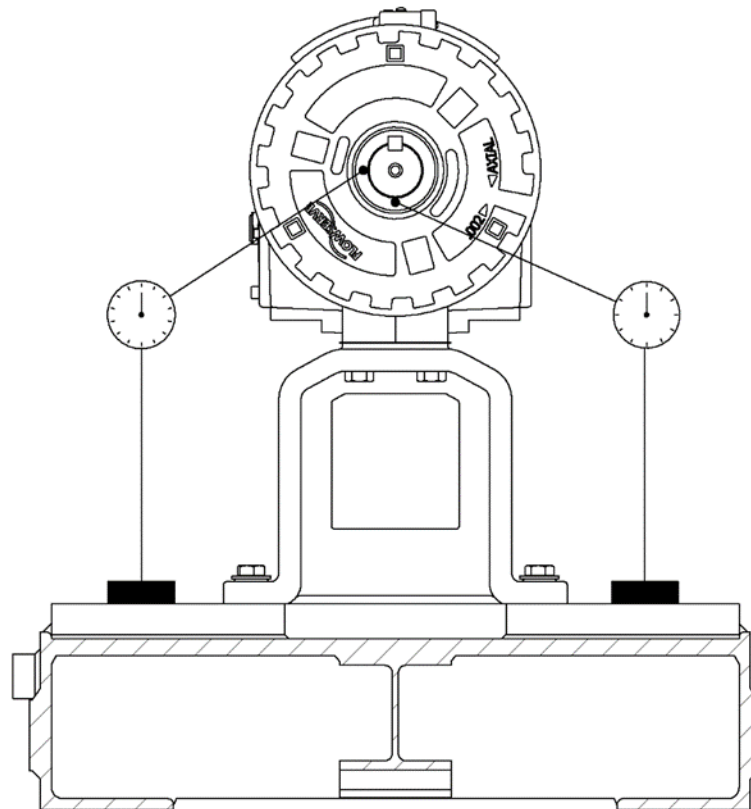

Figure 42: Pipe Strain Movement

8.6.11.2 Final alignment

Misalignment of the pump and motor shafts can cause the following problems:

- Failure of the mechanical seal
- Failure of the motor and/or pump bearings
- Failure of the coupling
- Excessive vibration/noise

The schematics below show the technique for a typical reverse rim alignment using dial indicators. It is important that this alignment be done after the flanges are connected, and at typical operating temperatures.

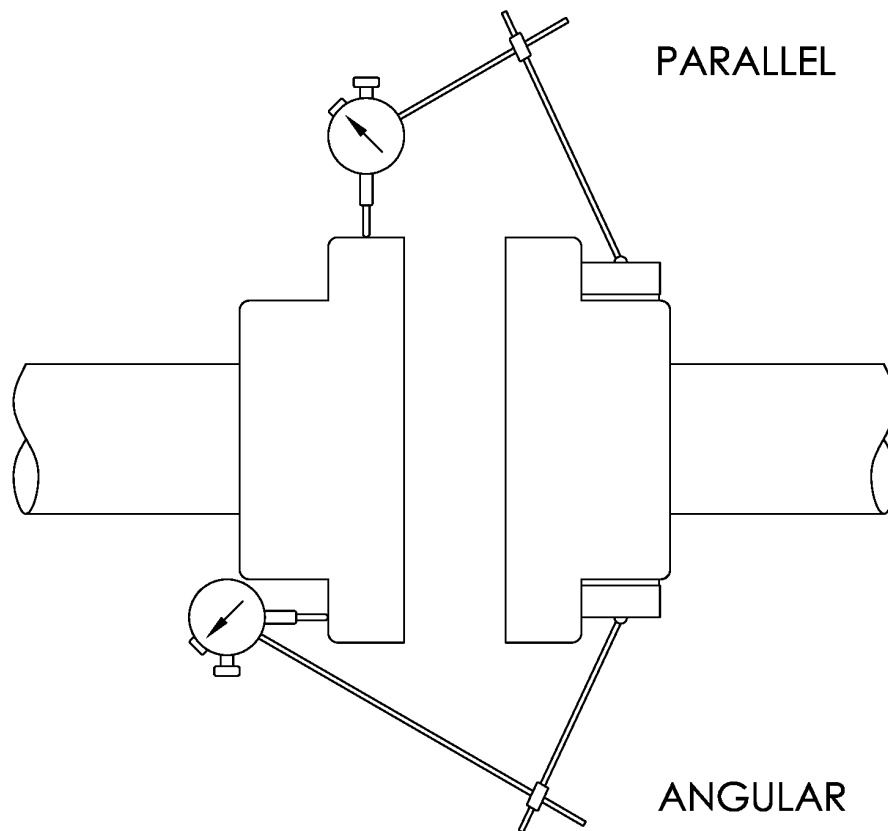

Figure 43: Alignment

Many companies today are using laser alignment which is more sophisticated and accurate technique. With this method a laser and sensor measure misalignment. This is fed to a computer with a graphic display that shows the required adjustment for each of the motor feet.

Detailed final alignment instructions are outside the scope of this document. Only experienced trained personnel should perform the final alignment. Flowserve can provide this service at additional cost.

See Section 5.3.7 for recommended final shaft alignment limits.

8.6.11.3 Vibration analysis

Vibration analysis is a type of condition monitoring where a pump's vibration “signature” is monitored on a regular, periodic basis. The primary goal of vibration analysis is extension of Mean Time Between Pump Maintenance (MTBPM). By using this tool Flowserve can often determine not only the existence of a problem before it becomes serious, but also the root cause and possible solution.

Modern vibration analysis equipment can not only detect if a vibration problem exists, but can also suggest the possible source of the problem. On a centrifugal pump, these causes can include the following:

- Unbalance
- Misalignment
- Soft-foot
- Defective bearings
- Resonance
- Hydraulic forces
- Pipe Strain
- Cavitation
- Recirculation

Once identified, the problem can be corrected, leading to increased MTBPM for the pump. Flowserve does not make vibration analysis equipment; however, Flowserve strongly urges customers to work with an equipment supplier or consultant to establish an on-going vibration analysis program. See note 4 under Table 23: *Measurements and tolerances*, regarding acceptance criteria.

8.7 Power end assembly

PTFE tape provides a very reliable seal over a wide range of fluids, but it has a serious shortcoming if not installed properly. If, during application to the threads, the tape is wrapped over the end of the male thread, the tape is wrapped over the end of the male thread, strings of the tape will be formed when threaded into the female fitting. These strings can then tear away and lodge in the piping system.

If this occurs in the seal flush system, small orifice can become blocked effectively shutting off flow. For this reason, Flowserve does not recommend the use of PTFE tape as a thread sealant.

Flowserve has investigated and tested alternate sealants and has identified LOCTITE® 567™ provides an effective seal on tapered threads. The lubricating properties of this compound prevent galling on all metal pipe threads and fittings. LOCTITE® 567™ offers high temperature performance and oil tolerance.

 **CAUTION** It is important that all pipe threads be sealed properly.

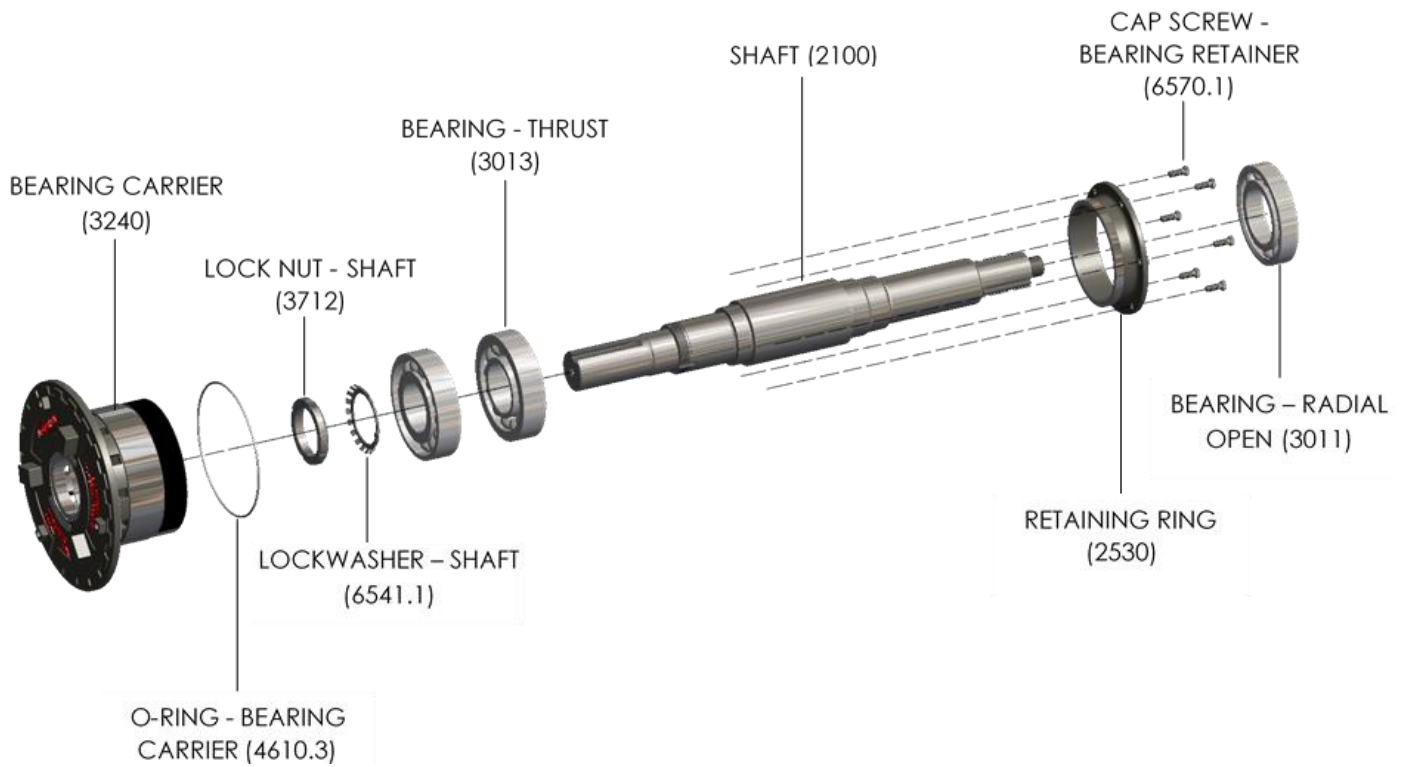

Figure 44: Rotor Assembly, Oil

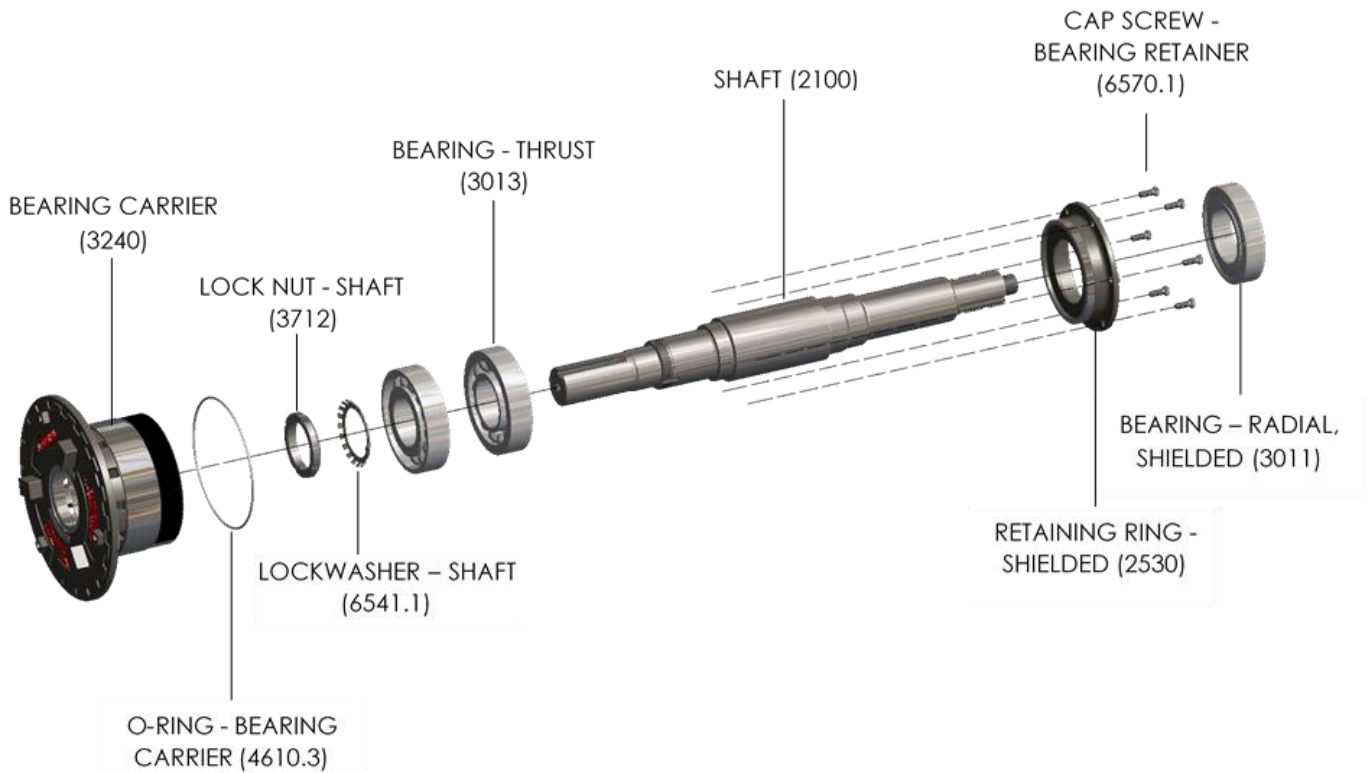

Figure 45: Rotor Assembly, Grease

8.7.1 Bearing installation

Mounting of bearings on shafts must be done in a clean environment. Bearings and power end life can be drastically reduced if even very small foreign particles work their way into the bearings. Wear clean gloves.

Bearings should be removed from their protective packing only immediately before assembly to limit exposure to possible contamination. After removing the packing, they should only come in contact with clean hands, fixtures, tools and work surfaces.

Table 25: *Flowserve Mark 3 Group 4 Bearings* gives the SKF part numbers for bearings in Flowserve Mark 3 Group 4 pumps. Note that the term Inboard Bearing (IB) refers to the bearings nearest to the casing. Outboard Bearing (OB) refers to the bearings nearest to the motor. See Figure 23: *Bearing Shield Orientation*

NOTICE Both bearings have a slight interference fit which requires that they be pressed on the shaft with an arbor or hydraulic press. Tables: 24 identifies the bearings fits. Even force should be applied to only the inner race. Never press on the outer race, as the force will damage the balls and races.

An alternate method of installing bearings is to heat the bearings to 93 °C (200 °F) by means of an oven or induction heater. The shaft temperature must be below 38 °C (100 °F) before attempting to install bearings. With this approach the bearing must be quickly positioned on the shaft.

Never heat the bearings above 110 °C (230 °F). Doing so may cause the bearings fit to permanently change, leading to early failure.

1. Install the radial IB bearing [3011] on the shaft [2100]
If the power end is equipped with single shielded re-greaseable bearings, position shield, as shown in Figure 23: *Bearing Shield Orientation*.
2. Before installing the thrust bearings [3013] on the shaft [2100]. Place the bearing retainer [2530.1] onto the outboard end of the shaft and slide down to the inboard bearing.
3. Install the duplex angular contact bearings. The bearing must be mounted back-to-back with the wider thrust sides of the outer races in contact with each other shown in Figure 46. Only bearings designed for universal mounting should be used. The SKF designation is "BEGAY".

NOTICE The inboard bearings must be positioned against the shoulder and the bearing retainer placed on the shaft oriented, as shown in Figure 23: *Bearing Shield Orientation*.

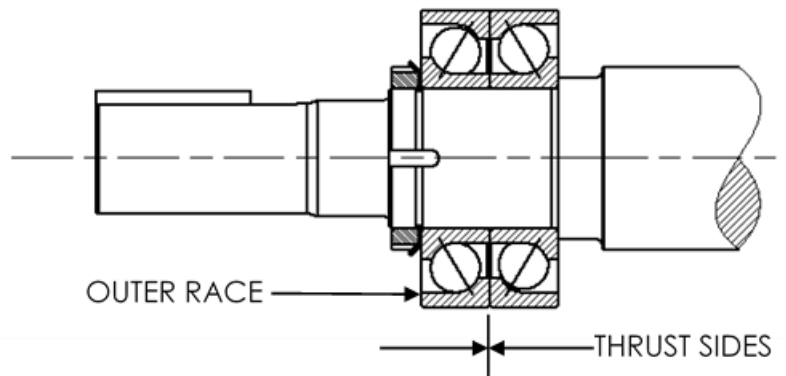

Figure 46: Duplex angular contact bearing

NOTICE

It must be understood that fixtures and equipment used to press the bearing must be designed so no load is ever transmitted through the bearing balls. This would damage the bearing.

4. If the thrust bearing [3013] is installed by the heating method, the install the locknut [3712] immediately after the bearing is placed on the shaft and tightened to ensure the bearing remains in contact with the shaft shoulder. As the bearing cools tighten the locknut repeatedly. Once cool remove the locknut.
5. Install lock washer [6451.1] and locknut [3712]. Torque the locknut to the minimum value shown in Table 21: *Torque Requirements*. Then continue turning the locknut clockwise until a single notch aligns with a tang on the lock washer. Bend one of the lock washer tangs into the corresponding groove on the locknut.
6. Let the shaft assembly cool to room temperature before proceeding to the bearing carrier [3240] installation. Protect from airborne debris.

Table 25: Flowserve Mark 3 Group 4 Bearings

Frame	Type of bearing	Duplex angular contact ball bearing (outboard) ⁶	Deep groove ball bearing (inboard) ⁶
41 K	Oil bath/mist – open	7316 BEGAY	6218/C3 ¹
	Re-greaseable single shielded	Note 4	6218-Z/C3 ²
42 K	Oil bath/mist – open	7318 BEGAY	6220/C3 ¹
	Re-greaseable single shielded ²	Note 4	6220-Z/C3 ²

Notes:

1. These bearings are open on both sides. They are lubricated by oil bath or oil mist.
2. These bearings are pre-greased by Flowserve. Replacement bearings will generally not be pre-greased, so grease must be applied by the user. They have a single shield, which is located away from the grease reservoir. The grease reservoir is initially filled with grease by Flowserve. Lubrication fittings are provided, to allow the customer to periodically replenish the grease, as recommended by the bearings and/or grease manufacturer.
3. The codes shown are SKF codes. Standard inboard bearings have the C3, greater than “normal” clearance. These clearances are recommended by SKF to maximize bearing life, in most applications. Flowserve Engineering may specify other clearances in some applications. Always verify the replacement bearing designation is identical to the original.

-
4. Re-greaseable – single shielded bearings are not available in the duplex configuration; however, open oil bath-type bearings are used for the re-greaseable configuration. The bearing retainer features an integral shield to retain grease. These bearings must be pre-greased during assembly. Lubrication fittings are provided, to allow the user to periodically replenish the grease, as recommended by the bearing and/or grease manufacturer.
 5. Deep groove bearings configurations are supplied only with steel cages. Angular contact ball bearings are supplied with machined brass cages.
 6. Only SKF – Explore performance class bearings are approved for uses in the Mark 3 Group 4 pump. SKF bearing are often counterfeited. Purchasing bearings from Flowserve to assure authenticity. If bearings are purchased from a non-Flowserve supplier and are suspected to be counterfeit, SKF advises that sharp pictures of all visual markings on the bearing and/or its package is taken and sent to genuine@skf.com T.

8.7.2 Bearing carrier installation

1. Install new O-ring [4610.3] onto the bearing carrier.
2. Slide the bearing carrier [3240] over the outboard (OB) bearing [3013].
3. Slide the bearing retainer [2530] against the OB bearing. Install the (6) six socket head cap screws [6570.1]. See Table 21: *Torque Requirements*, for correct torque values.

8.7.3 Rotor installation

1. Place the bearing housing, with the inboard bearing bore facing down, on a work surface or assembly fixture capable of supporting a minimum of 227 kg (500 lb). A 230 to 254 mm (9.00 to 10.00 in) diameter opening in the work surface is require for the end of the bearing housing to pass through. The opening allows the shaft [2100] pass through the bearing housing. 18 in of clearance is required below the work surface, allowing the shaft [2100] pass through the bearing housing.
2. *If previously removed, reinstall the thrust bearing oil return port plug [6569.5] in the bearing housing [3200]. Apply LOCTITE® 567™ to the plug prior to installation. Failure to install this plug will result is a total loss of lubricating oil. See Figure 34: RPE4 Power End Assembly for the correct location.*
3. Install a swivel lifting eye on the outboard end of the shaft. The internal shaft threads are ½-13 UNC – 2B, 1.00 in thread depth. Hook the lifting eye and carefully lift the rotor assembly in to a vertical position with a crane.
4. Lubricate the bearing carrier [3240] O-ring and threads, and bearing housing [3200] internal bores with oil. The shaft, bearings, and bearing carrier, *rotor assembly*, can now be installed into the bearing housing. See Figures 44 & 45
5. Slowly lower the rotor assembly in to the bearing housing [3200] until the bearing carrier [3240] threads contact the bearing housing threads. See Figure 34: *RPE4 Power End Assembly* for the correct orientation.
6. To avoid damaging the threads the they must be properly indexed. With the rotor assembly still attached to the crane, and a portion of the rotor assemblies weight still supported, rotate the bearing carrier [3240] counter-clockwise, until the rotor assembly drops approximate 1.6 mm (0.06 in) further in to the bearing housing [3200]. The bearing housing and carrier threads are now indexed.
7. Thread the bearing carrier [3240] into the bearing housing [3200] by turning it clockwise. Thread the bearing carrier onto the housing until the carrier flange is approximately 3 mm (0.13 in.) from the bearing housing. Install the (3) three set screws [6570.3] loosely, not to contact the bearing housing.

8. Reinstall any tags, plugs, site gages and oiler, as shown.
 - a) APE4, ASME Power End (See Figure 33)
 - If the adapter is to be install immediately after completion of the power end, do not install Radial bearing plugs [6569.4] & [6569.5], at this time.
 - b) OPE4, Oiler Power End (See Figure 34)
 - If the adapter is to be install immediately after completion of the power end, do not install Radial bearing plugs [6569.4] & [6569.5], at this time.
 - c) RPE4, Regreaseable Power End (See Figure 35)
 - If the adapter is to be install immediately after completion of the power end, do not install the Radial bearing grease fitting [3853.2], and Radial bearing relief fitting [9200]
 - d) MPE4, (Not Shown) all opening are plugged
 - If the adapter is to be install immediately after completion of the power end, do not install Radial bearing plugs [6569.4] & [6569.5], at this time.

8.7.4 Adapter Installation

1. Assemble the adapter [1340] to the bearing housing [3200]. Thread the cap screws [6570.5] through the adapter and into the tapped holes in the bearing housing.
2. Install the radial bearing plugs [6569.4] & [6569.5], or radial bearing grease fitting [3853.2], and radial bearing relief fitting [9200], as required.
3. If the pump is equipped with a hook type sleeve [2400], install the sleeve O-ring [4610.4] in the sleeve's internal groove. Lubricate the O-ring with oil or Parker-O-Lube. Slip the sleeve into place over the impeller end of the shaft [2100].

8.7.5 Bearing housing seals

8.7.5.1 Flowserve® Bearing Gard™ Bearing Isolators

The standard bearing housing seal is the Flowserve Bearing Gard™. It is a permanent, non-wearing bearing protection device. Its main purpose is to retain lubrication in the bearing housing and prevent the ingress of contamination as this can lead to premature failure of the lubrication and bearings. The Bearing Gard™ also services to regulate the passage of atmosphere in and out of the bearing housing.

NOTICE

Bearing Gard's labyrinth is designed to contain oil and repel water. It is not designed for use in either horizontal or vertical application that are flooded with oil or other liquid.

NOTICE

To ensure safe and reliable operation of the Bearing Gard™ follow all installation, operation, and maintenance instructions. Failure to comply with these instructions may result in frictional heating of the Bearing Gard™ components and will result in loss in performance.

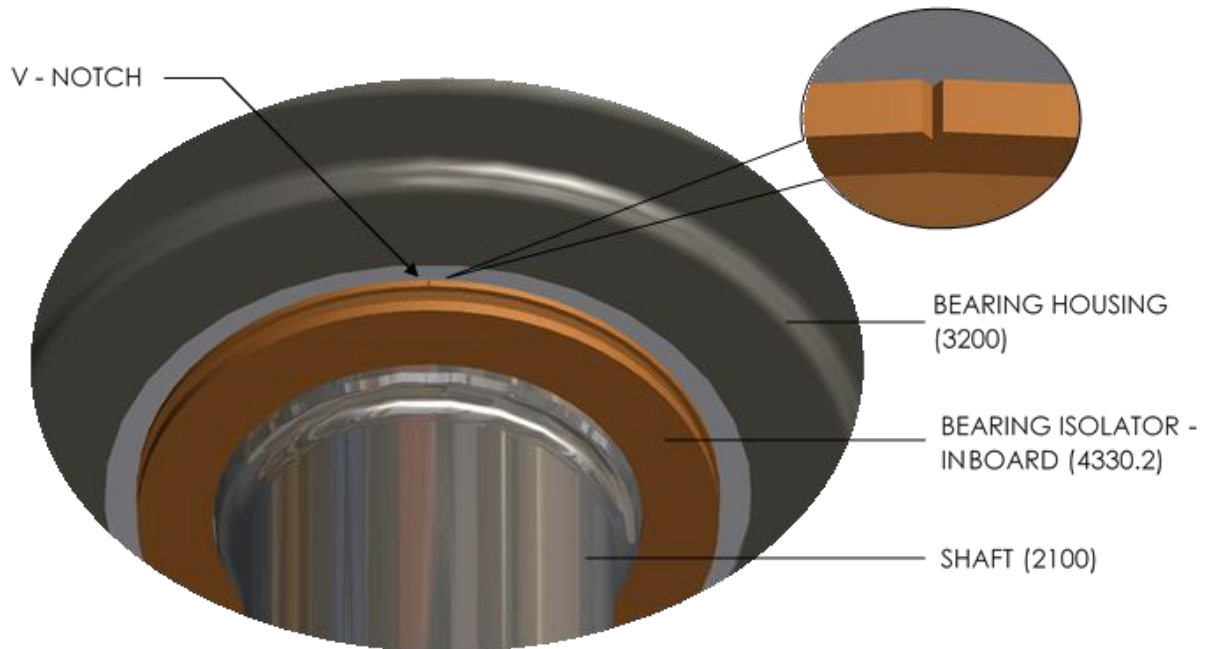

Figure 47: Inboard (IB) Bearing Gard™ Orientation (V-Notch)

8.7.5.2 Preparation for Installation

Do not disassemble the Bearing Gard™. It is designed to be installed as an assembly. Leave the Bearing Gard™ in its original packaging until installation.

1. Inspect for and remove sharp edges from the housing bore, and shaft steps where Bearing Gard™ O-Rings must pass.
2. Thoroughly clean both the shaft and housing bore.
3. Ensure Bearing Gard™ shaft O-ring position is located on an area of the shaft free from scratches, nicks, or dings.
4. Shaft and housing surface must be 0.8 micrometer (32 µin) or better.

8.7.5.3 Inboard Installation [4330.2]

See section 8.7.5.1 for proper V-Notch position before installing. Do not disassemble the Bearing Gard™. It is designed to be installed as an assembly. Leave the Bearing Gard™ in its original packaging until installation.

1. Lightly lubricate O-rings, shaft, and housing bore with the lubricant provided.
2. Align the Bearing Gard™ in housing so the oil and contaminant outlets are located on the bottom at 6 o'clock. The V-Notch must be vertically up when the pump assembly is complete.
3. Use an arbor press to push the Bearing Gard™ over the shaft into the housing bore. The tool should contact as much of rotor surface as possible. Do not hammer or hit the Bearing Gard™ directly. A sleeve for pressing in the isolator can be made of a Delrin®, HDPE tube or similar engineered plastic.
4. Visually confirm the Bearing Gard™ is fully seated against the bearing housing shoulder.

5. Spin shaft by hand. Listen and feel for any shaft binding for rubbing. If binding or rubbing occurs, repeat step 4 to reseal the isolator.
6. If shaft binding or rubbing remains, remove the Bearing Gard™ and verify equipment is within tolerance shown below in Table 26: *Bearing Gard™ Tolerance & Limits*.
7. Correct any defect and repeat steps 1 thru 4.

8.7.5.4 Outboard Installation [4330.1]

The outboard Bearing Gard™ will function in any radial position.

1. Rotate the power end assembly, so that the outboard end (coupling end) is facing up.
2. Lightly lubricate O-rings, shaft, and housing bore with the lubricant provided.
3. Use an arbor press to push the Bearing Gard™ over the shaft into the housing bore. The tool should contact as much of rotor surface as possible. Do not hammer or hit the Bearing Gard™ directly. A sleeve for pressing in the isolator can be made of a Delrin®, HDPE tube or similar engineered plastic.
4. Visually confirm the Bearing Gard™ is fully seated against the bearing housing shoulder.
5. Spin shaft by hand. Listen and feel for any shaft binding for rubbing. If binding or rubbing occurs, repeat step 4 to reseal the isolator.

Table 26: Bearing Gard™ Tolerance & Limits

Parts	Tolerance	
Shaft	± 0.051 mm	± 0.002 in.
Housing	± 0.025 mm	± 0.001 in.
Maximum axial movement (TIR)	0.63 mm	0.025 in.
Maximum radial runout (TIR)	0.13 mm	0.005 in.
Maximum Temperature *	190 °C	375 °F
Maximum Speed	30 m/s	6000 ft/min

* For ATEX parts, see attached document that is provided with pump

8.7.5.5 Lip Seals

NOTICE

Lip seals are not available. Shaft design and finishes DO NOT accommodate their operation. ASME B73.1 specifies labyrinth-type bearing isolators as standard. Flowserve no longer recommends lip seals on ASME B73.1 Chemical Process Pumps.

8.7.5.6 INPRO/SEAL® VBXX®-D Bearing Isolators

The installation instructions for the INPRO/SEAL® VBXX®-D bearing isolators are identical to the Flowserve Bearing Gard™, with the following modifications

1. The stator has an interference fit in the housing and the elastomer O-ring located on the outside diameter (O.D.) of the seal has been sized to overfill the groove in which it is located. When installing the seal into its corresponding housing, in addition to compressing the O-ring a certain amount of material may shear off. This sheared material should be removed.
2. If the INPRO/SEAL® is removed and reinstalled for any reason, replace the stator O-ring, as some of the material may have sheared off during the initial installation.
3. Install the inboard seal in the bore of the bearing housing with the single expulsion port positioned at the bottom 6 o'clock position. A V-Notch is not present on the stator to verify orientation after assembly.

8.7.5.7 Other Bearing Isolators and Magnetic seals

Follow the installation instruction provided by the manufacturer.

8.7.6 Operation

1. The maintain pump speed above 400 rpm, when Bearing Gard™ isolators are installed.
2. Contact your Flowserve seal representative for technical support of the Bearing Gard™.

8.8 Wet end assembly

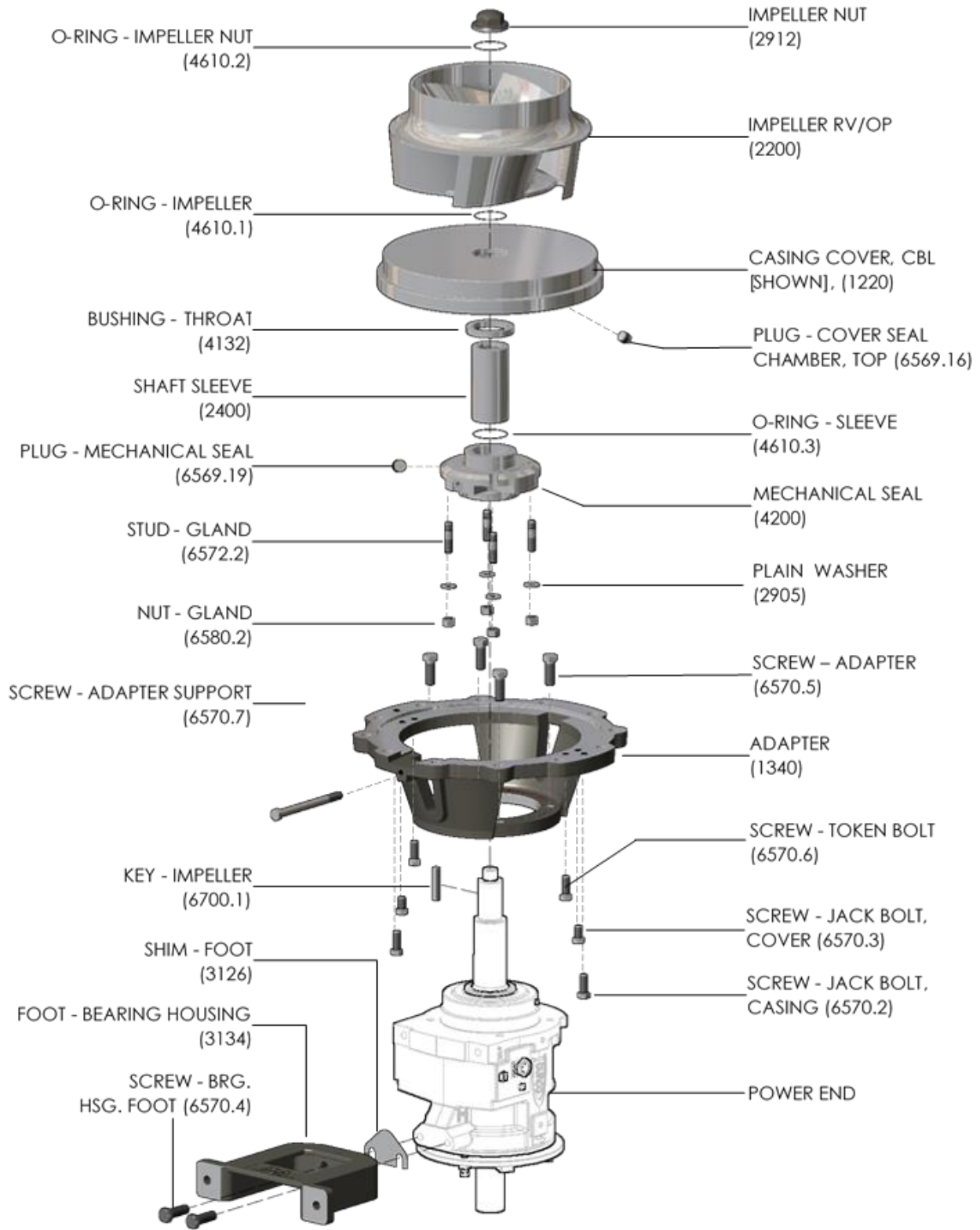

Figure 48: Back Pullout Assembly

8.8.1 Cartridge mechanical seals

Review the seal assembly instructions and drawings provided by the seal manufacturer.

1. A nose cone is not required. The outside diameter shaft [2100] or sleeve [2400] end is machined with a 20-degree lead chamfer to facilitate installation of the mechanical seal [4200]. Lubricate the shaft or sleeve and the mechanical seal O-ring (not shown) with the supplied lubricant or Parker-O-Lube.
2. Place the mechanical seal on the shaft end with the seal collar facing the bearing housing [3200]. Slide the mechanical seal onto the shaft until it lightly touches the bearing isolator [4330.2]. *Orient the seal ports as shown on the seal assembly drawing.*
3. Install the casing cover [1220] to the adapter [1340] with the word, "TOP" oriented, as shown in Figure 49 and 50, secure with (2) cap screws [6570.6]; token bolts. Now slide the mechanical seal to the casing cover [1220], using gland studs [6572.2], washers [2905] and gland nuts [6580.2], fasten the seal to the cover. Torque the gland studs to the value shown in the instructions supplied with the seal.
4. Install the impeller [2200] and then set the impeller clearance, as instructed in Section 8.8.3, *Setting impeller clearance and replacement.*
5. Hand tighten the seal collar set screw to lock the rotating unit to the shaft. Then torque to the value shown in the instructions supplied with the seal. If no value is provided torque set screws with 3/8-16 threads to 47 Nm (35 lb-ft) and 5/16-18 threads to 27 Nm (20 lb-ft).
6. Finally remove centering clips or tabs from the seal.

NOTICE

Retain centering clips and tabs for future maintenance.

8.8.2 Packing and split gland installation

1. Install the casing cover [1220] to the bearing housing adapter by using the cap screws [6570.6], token bolts.
2. Install and set the impeller clearance as outlined in Section 8.8.3
3. Install packing rings [4130] and lantern ring packing [4134] into the packing box in an alternating sequence. The typical order is, as shown in Figure 30. Always stagger the end gaps 90 degrees to ensure a better seal. To speed installation of each ring, have an assistant turn the pump shaft in one direction. This movement of the shaft will tend to draw the rings into the packing box. Corrugated cardboard rolled around the shaft or split tubing can be used to tamp the packing rings in to the packing box. Install rings in to the box in this order. P = Packing Ring, L = Lantern Ring
 - a. Clean service operating on a suction lift: 2P-L-3P
 - b. Clean service operating with a flooded suction: 2P-L-3P
 - c. Clean service with >2 barg (30psig) suction pressure: 3P-L-2P or 6P
 - d. Dirty service operating on a suction lift to <4barg (60psig): 3P-L-2P
 - e. Dirty service with >4 barg (60psig) suction pressure: *Packing Not Recommended*
4. The split gland [4120] is an assembly of two matched gland halves. Install the gland halves around the shaft. Bolt the halves together using (2) cap screws [6570.10] to form a gland assembly.
5. Attached the gland assembly [4120] using studs [6572.2], washers [2905] and gland nuts [6580.2].
6. Lightly snug up the gland nuts. Final adjustments must be made after the pump has begun operation. See Section 3.5.3.1 Seal/packing support system, for final adjustment procedures.

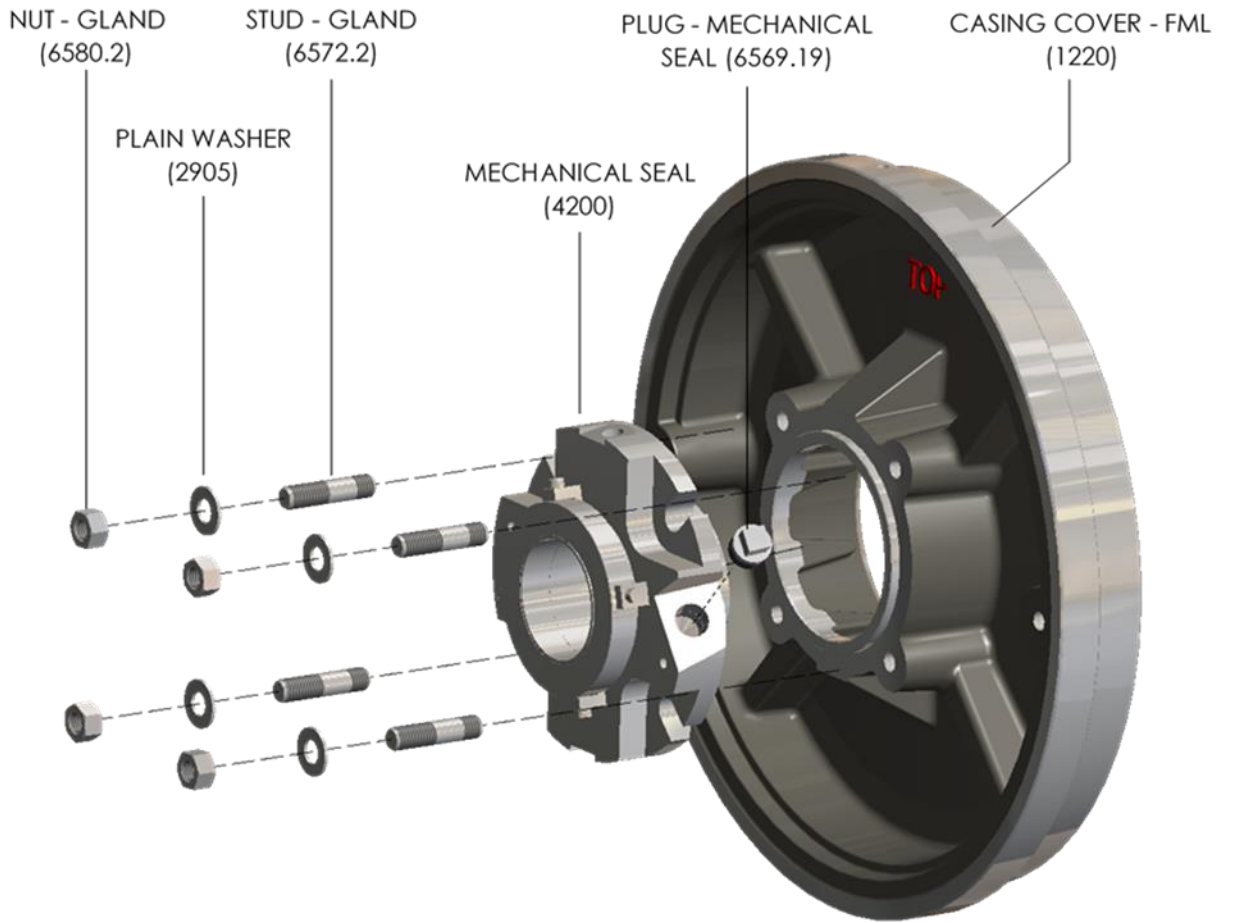

Figure 49: FML Cover with Cartridge Seal

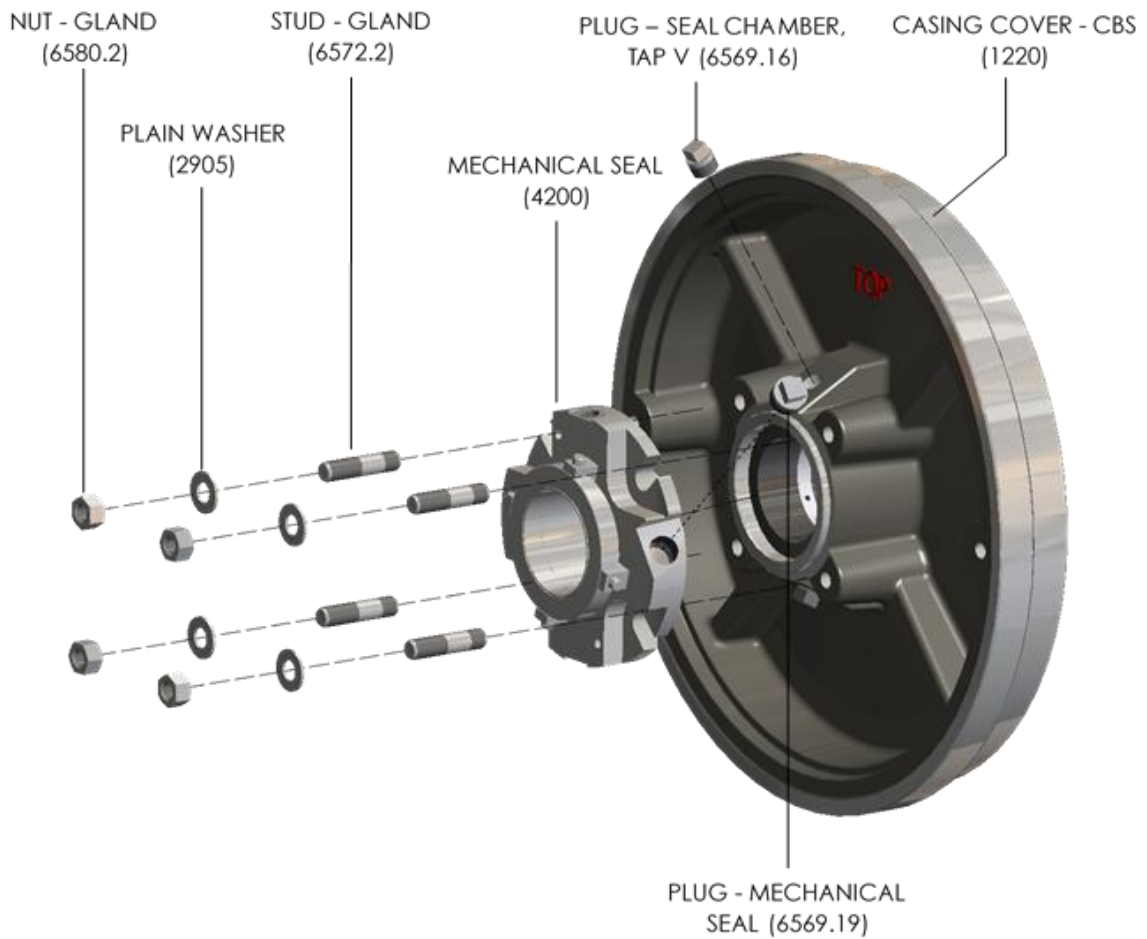

Figure 50: CBS Cover with Cartridge Seal

8.8.3 Setting impeller clearance and impeller replacement

A new impeller O-ring [4610.1] and impeller nut O-ring [4610.2] must be installed whenever the impeller has been removed from the shaft. Impeller clearance settings may be found in Section 5.3.3. Impeller balancing instruction may be found in Section 8.6.7.



Do not adjust the impeller clearance with the seal set. Doing so may result in seal leakage and/or damage. Hazardous material may be released.

CAUTION

The impeller could have sharp edges, which could cause injury. It is very important to wear heavy gloves.

CAUTION

It is recommended that a crane and rigging or two people install a Group 4 impeller. Depending on pump size and trim, impeller weight is 32-77 kg (70-170 lbs).

8.8.3.1 Removal of Impeller

Follow the steps below to properly remove impeller, refer to Figure 51. For lifting techniques see section 4.4.1, *Lifting pump components*.

1. Ensure that pump casing [1100] is removed.
2. Place power end with assembly fastened on a level work surface, by the foot [3134].
3. Place the impeller wrench supplied in the Mark 3 Group 4 tool kit on the shaft [2100] with the shaft key [6700.2].
4. Turn the impeller wrench clockwise until impeller wrench handle touches the work surface.
5. Remove the impeller nut [2912] by rotating counter clockwise using an impact wrench.
6. Discard impeller nut O-ring [4610.2]
7. Secure impeller with suitable clamp. Remove impeller and impeller key [6700.1] from the shaft. Refer to Section 4.4.1.3 Impeller [2200] for lifting instructions.
8. Discard impeller O-ring [4610.1].
- 9.



Figure 51: Removing Impeller

8.8.3.2 Installing new impeller

NOTICE

Ensure Back Pullout Assembly, Figure 48, is properly installed up to the Cover [1220]

1. Start the impeller [2200] installation by placing impeller wrench onto the shaft with shaft key.
2. Turn impeller wrench clockwise until impeller wrench touches the work station.
3. Add new impeller O-ring [4610.1].
4. Place impeller key in slot between shaft and impeller.
5. Slide impeller onto the shaft. Ensure the impeller keyway is aligned with impeller key.
6. Install a new impeller nut O-ring [4610.2] on the impeller nut [2912].
7. Lubricate the impeller nut threads. Hand tighten impeller nut.
8. Verify the impeller and impeller nut are fully seated and the O-Rings are not pinched.
9. Tighten the impeller nut to the torque value listed in *Table 21: Torque Requirements*. See Note 1



Figure 52: Installing Impeller

8.8.3.3 Installation and clearance setting for Reverse Vane (RV) Impellers

Flowserve reverse vane (RV) impellers are set off the cover. This allows the impeller to be set without the casing. Set the impeller clearance by loosening the set screws [6814] and rotating the bearing carrier [3240] to obtain the proper clearance. Turn the bearing carrier counter-clockwise until the impeller [2200] comes into light rubbing contact with the cover [1220]. Rotating the shaft at the same time will accurately determine this zero setting. Now, rotate the bearing carrier clockwise to get the proper clearance. Refer to Table 15: *Impeller Clearance Setting* for the impeller clearance based on the fluid operating temperature.

Rotating the bearing carrier one width of the indicator patterns cast into the bearing carrier moves the impeller axially 0.10 mm (0.004 in.). See Figure 53

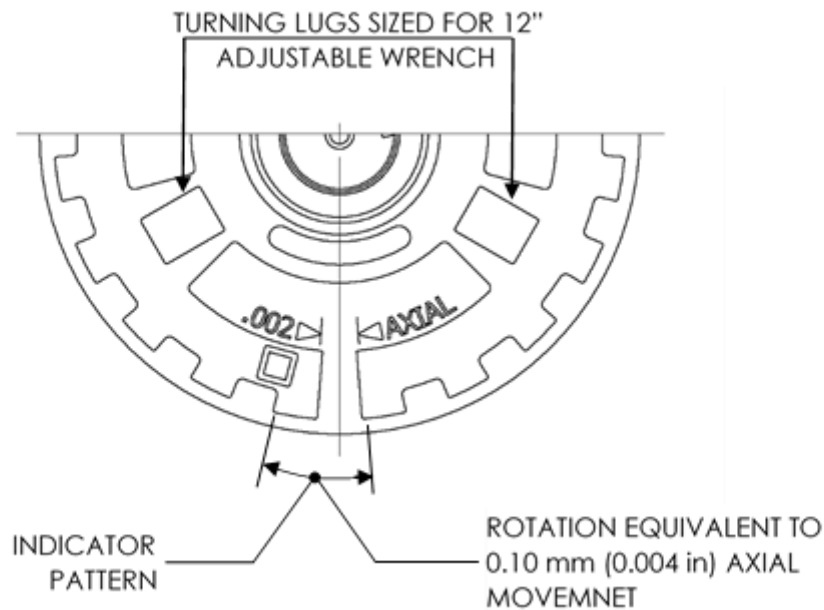

Figure 53: Bearing Carrier Indicator

Determine how far to rotate the bearing carrier by dividing the desired impeller clearance by 0.10 mm (0.004 in.) (one indicator pattern). Tightening the set screws [6814] will move the impeller 0.05 mm (0.002 in.) closer to the cover, due to the internal looseness in the bearing carrier threads. This must be considered when setting impeller clearance. Rotate the bearing carrier clockwise the required amount to obtain desired RV impeller clearance to the cover.

NOTICE After adjustment, uniformly tighten the (3) three set screws [6814] in incremental steps up to the final torque, value locking the bearing carrier in place. See Table 21: *Torque Requirements*



Figure 54: Bearing Carrier Markings

Example: When setting a pump with a RV impeller with an operating temperature of 100 °C (212 °F), the impeller setting the off the cover [1220] wear surface is 0.81 mm (0.032 in.), as shown in Table 15: *Impeller Clearance Setting*. To compensate for additional movement caused by tightening the set screws [6814], add 0.05 mm (0.002 in.) to the specified impeller clearance. Thus, an initial adjustment of 0.86 mm (0.034 in.) is needed.

First, turn the bearing carrier [3240] counter-clockwise until the impeller [2200] comes into light rubbing contact with the cover. Using a felt tip pen mark the initial reference point on the bearing housing [3200] and the bearing carrier, as shown in Figure 54. Then make mark a second mark on the bearing carrier the predetermined number of indicator patterns counter-clockwise from the initial reference point. Rotate the bearing carrier clockwise until the second mark aligns with the initial reference point on the bearing housing.

To complete the setting, lock the bearing carrier. Uniformly tighten the (3) three set screws [6814] in incremental steps up to the final torque. See Table 21: *Torque Requirements*

To determine the number of indicator patterns that you will need to rotate the carrier, divide 0.10 mm (0.004 in.) into the desired setting;

From above 0.86 mm / 0.10 mm or (0.034 in. / 0.004 in.) = 9.5 patterns, round up to the nearest half pattern if required. Rotate the bearing carrier clockwise 9.5 indicator patterns which results in a clearance of 0.81 mm (0.032 in.).

8.8.3.4 Installation and clearance setting for Semi-Open Vane (OP) Impellers

Like all semi-open style impellers, the Flowserve semi-open impeller clearance must be set off the casing. The casing must be installed to accurately set the impeller clearance. (Realizing that this can be difficult, Flowserve strongly promotes the use of reverse vane impellers, which do not require the presence of the casing to properly set.)

With the back pullout assembly installed in the casing [1100], See Section 8.8.4. Set the impeller clearance by loosening the set screws [6814] and rotating the bearing carrier [3240] to obtain the proper clearance. Turn the bearing carrier clockwise until the impeller [2200] comes into light rubbing contact with the casing [1100]. Rotating the shaft at the same time will assist in determine this zero setting. Now, rotate the bearing carrier clockwise to get the proper clearance. Refer to Table 15: *Impeller Clearance Setting* for the impeller clearance based on the fluid operating temperature.

Rotating the bearing carrier one width of the indicator patterns cast into the bearing carrier moves the impeller axially 0.10 mm (0.004 in.). See Figure 53

Determine how far to rotate the bearing carrier by dividing the desired impeller clearance by 0.10 mm (0.004 in.) (one indicator pattern). Tightening the set screws [6814] will move the impeller 0.05 mm (0.002 in.) closer to the cover [1240], due to the internal looseness in the bearing carrier threads. This must be considered when setting impeller clearance. Rotate the bearing carrier counter-clockwise the required amount to obtain the desired OP impeller clearance to the casing.

NOTICE

After adjustment, uniformly tighten the (3) three set screws [6814] in incremental steps up to the final torque, value locking the bearing carrier in place. See Table 21: *Torque Requirements*

See section 5.3.3 for impeller clearance settings.

Example: When setting a pump with a OP impeller with an operating temperature of 150 °C (302 °F), the impeller setting the off the casing [1100] wear surface is 0.81 mm (0.032 in.), as shown in Table 15: *Impeller Clearance Setting*. To compensate for additional movement caused by tightening the set screws [6814], subtract 0.05 mm (0.002 in.) to the specified impeller clearance. Thus, an initial adjustment of 0.76 mm (0.030 in.) is needed.

First, turn the bearing carrier [3240] clockwise until the impeller [2200] comes into light rubbing contact with the casing. Using a felt tip pen mark the initial reference point on the bearing housing [3200] and the bearing carrier, as shown in Figure 54. Then make mark a second mark on the bearing carrier the predetermined number of indicator patterns clockwise from the initial reference point. Rotate the bearing carrier counter-clockwise until the second mark aligns with the initial reference point on the bearing housing.

To complete the setting, lock the bearing carrier. Uniformly tighten the (3) three set screws [6814] in incremental steps up to the final torque. See Table 21: *Torque Requirements*

To determine the number of indicator patterns that you will need to rotate the carrier, divide 0.10 mm (0.004 in.) into the desired setting;

From above $0.76 \text{ mm} / 0.10 \text{ mm}$ or $(0.030 \text{ in.} / 0.004 \text{ in.}) = 8.5$ patterns, round up to the nearest half pattern if required. Rotate the bearing carrier clockwise 8.5 indicator patterns which results in a clearance of 0.81 mm (0.032 in.).

8.8.3.5 Back pullout assembly clearance setting for Semi-Open Vane (OP) Impellers

The above procedure, 8.8.3.4 Installation and clearance setting for Semi-Open Vane (OP) Impellers, is straightforward when doing the final setting of the impeller. However, it can be quite laborious when servicing a back pullout assembly as a spare and performing the preliminary setting to establish the location of the mechanical seal. For this reason, the following practice is recommended. Before the pump is taken out of service, install the mechanical seal locking clips or tabs. Loosen the seal collar set screws. Adjust the impeller, by turning the bearing carrier clockwise, until it touches the casing. Then rotate the bearing carrier counter-clockwise until the desired impeller clearance is obtained. Identify this location on the bearing carrier and then continue rotating the bearing carrier counter-clockwise until the impeller contacts the cover. Record the distance from the desired impeller clearance setting to when the impeller contacts the cover. The pump (back pullout assembly) is now removed from the casing and taken to the shop for maintenance. When it is time to set the seal, the impeller is simply set off the cover by the same distance recorded earlier.

NOTICE

The above technique is only applicable if all the original pump components are reinstalled. If the casing, cover, impeller or shaft is replaced, or casing gasket type changed this method must not be used.

8.8.4 Back pullout assembly installation in casing

1. Remove the adapter support screw [6570.7], not shown.
2. Install a new casing/cover gasket [4590.1] between the cover [1220] and casing [1100].
3. Lift the back pullout assembly in to the casing, See Section 4.4.1.6.
The pump casing and bearing housing feet must be on the baseplate or a machined worktable to align the feet on the same plane, prior to final tightening of the casing fasteners.
4. Lightly snug all casing nuts [6580.1]. Check that feet are in plane. If a 0.05 mm (0.002 in.) thick shim cannot be slid under the bearing housing or casing feet, continue to Step 5.
5. If the shim can be slid under a foot, loosen the casing nuts and rotate the bearing housing to bring the bearing housing foot in to plate. Repeat Step 4.
6. Tighten the casing nuts in a Cross-Pattern in three increments of final the torque value shown in Table 21: *Torque Requirements*. 30%, 60% and 100% of final torque.
7. Place the coupling key [6700.2] in the shaft [2100] keyway. Apply tape around the shaft and key. This will retain the key until the coupling is install.
8. The pump assembly is now complete. The (optional) IPS Beacon™ 2 [9050] can now be installed. A plastic thread protector or screw may be in the Beacon mounting threads. Remove if either is present. Attach the Beacon with button socket head cap screw [6570.8] and lock washer [6541.2]. Torque to value show in Table 21: *Torque Requirements*. See Figure 56

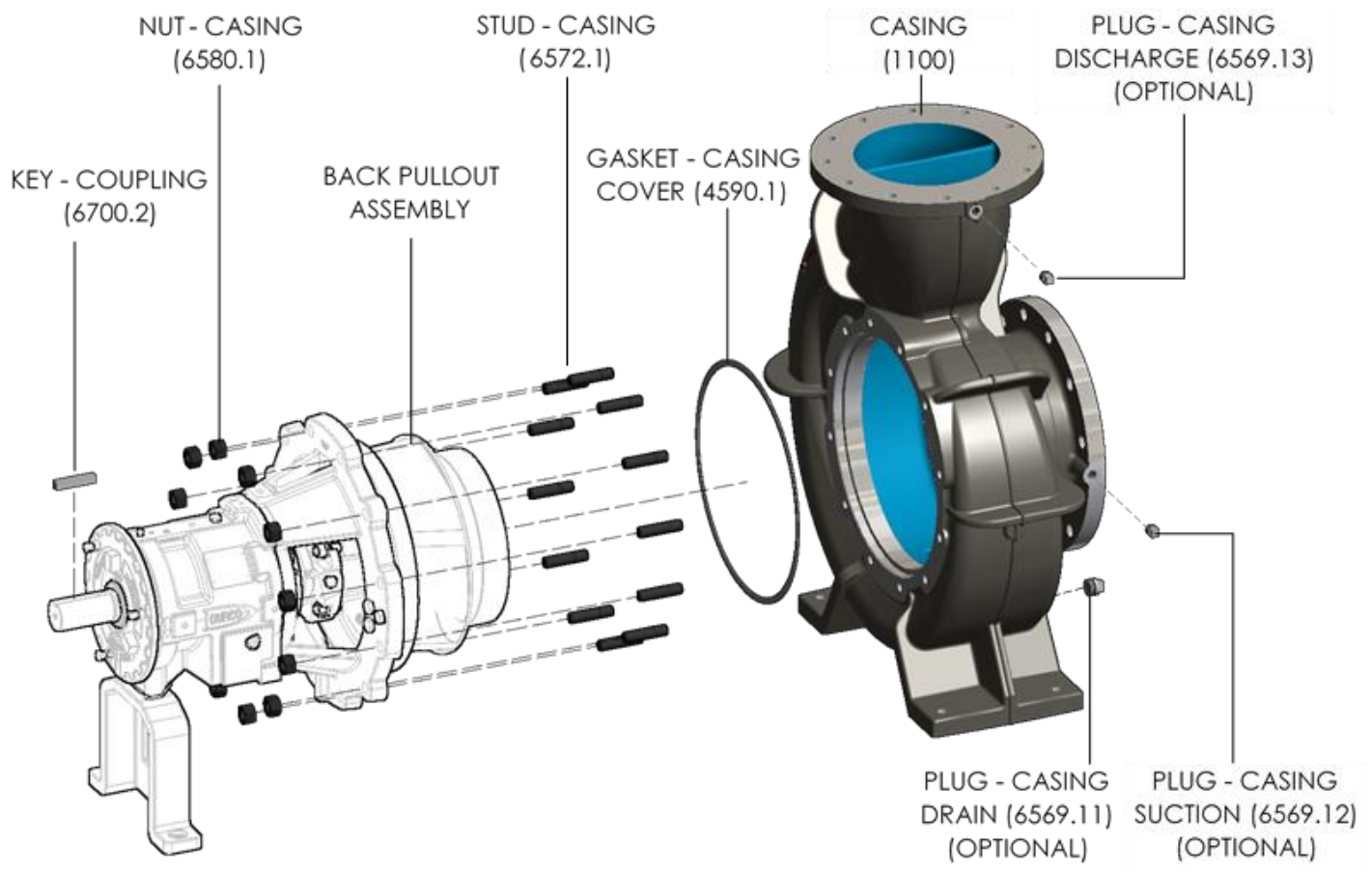

Figure 55: Final Pump Assembly

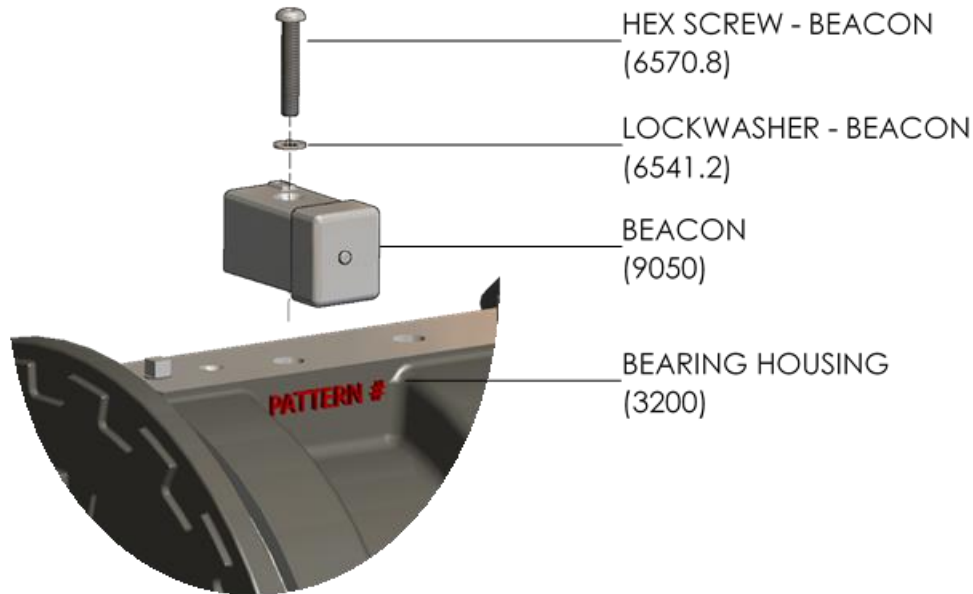

Figure 56: Beacon Assembly (Optional)

8.9 Post maintenance inspection



It is recommended that a maintenance plan and schedule be implemented, in accordance with these User Instructions, to include the following:

1. Any auxiliary systems installed must be monitored, if necessary, to ensure they function correctly.
2. Gland packing must be adjusted correctly to give visible leakage and concentric alignment of the gland follower to prevent excessive temperature of the packing or follower.
3. Check for any leaks from gaskets and seals. The correct functioning of the shaft seal must be checked regularly.
4. Check bearing lubricant level, and the remaining hours before a lubricant change is required.
5. Check that the duty conditions are in the safe operating range for the pump.
6. Check vibration, noise level and surface temperature at the bearings to confirm satisfactory operation.
7. Check dirt and dust is removed from areas around close clearances, bearings housings and motors.
8. Check coupling alignment and re-align if necessary.

See Section 6 *Commissioning*, for pre-commissioning procedures.

8.10 Spare parts stocking recommendation

The decision on what spare parts to stock varies greatly depending on many factors such as the criticality of the application, the time required to buy and receive new spares, the erosive/corrosive nature of the application, and the cost of the spare part. Section 8.5 identifies all of the components that make up each pump addressed in this manual.

Recommended spares are defined on the following basis:

- Class 1 – Start-up and commissioning spares
- Class 2 – Two-year spares requirements covering maintenance for this period
- Class 3 – Capital spares requirements

Flowserve keeps records of all pumps that have been supplied. Spare parts can be ordered from your local Flowserve sales engineer or from a Flowserve distributor or representative.

When ordering spare parts, the following information should be provided to Flowserve:

1. Pump serial number
2. Pump size and type
3. Part name – taken from the parts list/sectional drawing
4. Part item number – taken from the parts list/sectional drawing
5. Material of construction (alloy)
6. Number of parts required
7. Part number – taken from the parts list/sectional drawing*

*If an as built sectional drawing is available, provide sectional drawing number. Or if taken from an existing part.

The product size and serial number are provided on the nameplate.

SAFETY INSTRUCTIONS

To ensure continued satisfactory operation, replacement parts to the original design specification should be obtained from Flowserve. Any change to the original design specification (modification or use of non-standard part) will invalidate the product safety certification.

8.10.1 Spare parts per pump

The following spare parts are recommended for an individual pump installation. Were a population of identical pumps or a family of pumps utilizing the same power end exist, Section 8.10.2 applies.

Table 27: Recommended Spares & Consumable Items (Individual Pump)

Commissioning Spares (Class 1)	Two Years Operational Spares (Class 2)	Five Years Operational Spares (Class 3)	Part Description	
			Sleeved Shaft & Solid Shaft	
			Labyrinth Oil Seal	
			Description	Item
1	1	2	O-Ring – Impeller	4610.1
1	1	2	O-Ring – Impeller Nut	4610.2
N/A	2	4	O-Ring – Bearing Carrier	4610.3
N/A	2	4	O-Ring – sleeve	4610.4
N/A	N/A	1	Impeller	2200
N/A	N/A	1*	Casing Cover	1220
1	1	2	Gasket – Casing/Cover	4590.1
N/A	1	2	Radial Bearing	3011
N/A	1	2	Thrust Bearing	3013
N/A	1	2	Locknut -Shaft	3712
N/A	1	2	Lock Washer -Shaft	6541.1
N/A	1	2	Bearing Isolator – Outboard	4330.1
N/A	1	2	Bearing Isolator – Inboard	4330.2
N/A	1	2	Key - Impeller	6700.1
N/A	1	2	Key - Coupling	6700.2
N/A	N/A	1	Sleeve (if fitted)	2400
N/A	N/A	1	Shaft	2100

* abrasive service with an RV impeller

8.10.2 Spare parts per pump

The following spare parts are recommended with an installation population of identical pumps or a family of pumps utilizing the same power end exist.

Table 28: Recommended Spares & Consumable Items (Multiple identical pumps)

Item	Designation	Number of Pumps (including stand-by)						
		2	3	4	5	6/7	8/9	10(+)
2200	Impeller	1		2		3	30%	
2400	Sleeve (if fitted)	2		3		4	50%	
2912	Impeller nut	1		2		3	30%	
2100	Shaft	1		2		3	30%	
3712	Locknut - Shaft	1		2		3	4	50%
6541.1	Lock Washer - Shaft	1		2		3	4	50%
3011	Radial Bearing	1		2		3	4	50%
3013	Thrust Bearing**	1		2		3	4	50%
4590.1	Gasket – Casing/Cover	4	6	8		9	12	150%
4610.1	O-Ring – Impeller	4	6	8		9	12	150%
4610.2	O-Ring – Impeller Nut	4	6	8		9	12	100%
4610.4	O-Ring - Sleeve (if fitted)	2		3		4	50%	
4610.3	O-Ring – Bearing Carrier	4	6	8		9	12	150%
4330.1 / 4330.2	Bearing Isolators	1	2		3		30%	
4130	Gland Packing*	2		3		4	40%	
4134	Lantern Ring	1	2		3		30%	
4200	Mechanical Seal	1	2		3		30%	
-	Power end	-	-	-	-	-	1	2
6700.1	Key – Impeller	1		2		3	30%	
6700.2	Key - Coupling	1		2		3	30%	

*Full set of packing is (3) rings

**The duplex Thrust Bearing requires (2) two bearings for a complete assembly

9 Troubleshooting Guide

The following is a guide to troubleshooting problems with Flowserve Mark 3 pumps. Common problems are analysed and solutions offered. Obviously, it is impossible to cover every possible scenario. If a problem exists that is not covered by one of the examples, then refer to one of the books listed in Annex C "Additional Sources of Information" or contact a Flowserve sales engineer or distributor/representative for assistance.

Table 29: Trouble Shooting Recommendations

Pump not reaching design flow rate						
↓ Pump not reaching design head (TDH)						
↓ No discharge or flow with pump running						
↓ Pump operates for short period, then loses prime						
↓ Excessive noise from wet end						
↓ Excessive noise from power end						
↓						
					Possible Causes	Possible Remedies
●	●	●	●		Insufficient NPSH. (Noise may not be present).	Recalculate NPSH available. It must be greater than the NPSH required by pump at desired flow. If not, redesign suction piping, holding number of elbows and number of plans to a minimum to avoid adverse flow rotation as it approaches the impeller.
●	●	●			System friction head greater than anticipated.	Reduce system head by increasing pipe size and/or reducing number of fittings. Increase impeller diameter. (note: Increasing impeller diameter may require use of a larger motor.)
●	●	●			Entrained air. Air leak from atmosphere on suction side	<ol style="list-style-type: none"> 1. Check suction line gaskets and threads for tightness. 2. If vortex formation is observed in suction tank, install vortex breaker. 3. Check for minimum submergence
●	●				Entrained gas from process	Process generated gases may require larger pumps.
●	●				Speed too slow	Check motor speed against design speed.
●	●	●			Direction of rotation wrong	After confirming wrong rotation, reverse any two of the three leads on the three phase motor. The pump should be disassembled and inspected before it is restarted.
●	●				Impeller too small	Replace with proper diameter impeller. (NOTE: Increasing impeller diameter may require use of a larger motor.)
●	●				Impeller clearance too large	Reset impeller clearance.
●	●	●			Plugged impeller, suction line or casing which may be due to a product or larger solids.	<ol style="list-style-type: none"> 1. Reduce length of fiber when possible. 2. Reduce solids in the process fluid when possible. 3. Consider larger pump.
●	●				Wet end parts (casing cover, impeller) worn, corroded or missing.	Replace part or parts.

Pump not reaching design flow rate						
↓	Pump not reaching design head (TDH)					
	↓	No discharge or flow with pump running				
		↓	Pump operates for short period, then loses prime			
			↓	Excessive noise from wet end		
				↓	Excessive noise from power end	
					↓	
					Possible Causes	Possible Remedies
	●	●			Not properly primed.	Repeat priming operation, recheck instructions. If pump has run dry, disassemble and inspect the pump before operation.
	●	●		●	Impeller rubbing.	<ol style="list-style-type: none"> 1. Check and reset impeller clearance. 2. Check outboard bearing assembly for axial end play. 3. Pump running outside of the Allowable Operating Range AOR. Check flow.
	●	●			Damaged pump shaft, impeller.	Replace damage parts.
				●	Abnormal fluid rotation due to complex suction piping.	<ol style="list-style-type: none"> 1. Redesign suction piping, holding the number of elbows and planes to a minimum to avoid adverse fluid rotation as it approaches the impeller. 2. Add cruciform to the suction piping.
				●	Bearing contamination appearing on raceways as scoring, pitting, scratching or rusting caused by adverse environment and entrance of abrasive contaminants from atmosphere.	<ol style="list-style-type: none"> 3. Work with clean tools in clean surroundings. 4. Remove all outside dirt from housing before exposing bearings. 5. Handle with clean dry hands. 6. Treat a used bearing as carefully as a new one. 7. Use clean solvent and flushing oil. 8. Protect disassembled bearing from dirt and moisture. 9. Keep bearings wrapped in paper or clean cloth while not in use. 10. Clean inside of housing before replacing bearings. 11. Check oil seals and replace as required. 12. Check all plugs and tapped openings to make sure that they are tight.
				●	Brinelling of bearing identified by indentation on the ball races, usually caused by incorrectly applied forces in assembling the bearing or by shock loading such as hitting the bearing or drive shaft with a hammer.	When mounting the bearing on the drive shaft use a proper size ring and apply the pressure against the inner ring only. Be sure when mounting a bearing to apply the mounting pressure slowly and evenly.
				●	False brinelling of bearing identified again by either axial or circumferential indentations usually caused by vibration of the balls between the races in a stationary bearing.	<ol style="list-style-type: none"> 1. Correct the source of vibration. 2. Where bearings are oil lubricated and employed in units that may be out of service for extended periods, the drive shaft should be turned over periodically to relubricate all bearings surfaces at intervals of one to three months.
				●	Thrust overload on bearings identified by flaking ball path on one side of the outer race or in the case of maximum capacity bearings, may appear as a spalling of the races in the vicinity of the loading slot. (Please note: Maximum capacity bearings are not recommended in Mark 3 pumps.) These thrust failures are caused by improper mounting of the bearing or excessive thrust loads.	<ol style="list-style-type: none"> 1. Check the SG of the fluid pump 2. Check the suction pressure 3. Pump running outside of the Allowable Operating Range AOR. Check flow. 4. Follow the correct mounting procedures for the bearing.

Pump not reaching design flow rate						
↓	Pump not reaching design head (TDH)					
↓	No discharge or flow with pump running					
↓	Pump operates for short period, then loses prime					
↓	Excessive noise from wet end					
↓	Excessive noise from power end					
↓						
↓	Possible Causes					Possible Remedies
				●	Misalignment identified by fracture of ball retainer or a wide ball path on the inner race and a narrower cocked ball path on the outer race. Misalignment is caused by poor mounting practices or defective drive shaft. For example, bearing not square with the centerline or possibly a bent shaft due to improper handling.	Handle parts carefully and follow recommended mounting procedures. Check all parts for proper fit and alignment.
				●	Bearing damaged by electric arcing identified as electro-etching of both inner and outer ring as a pitting or cratering. Electrical arcing is caused by a static electrical charge emanating from belt drives, electrical leakage or short circuiting.	<ol style="list-style-type: none"> 1. Where current shunting through the bearing cannot be corrected, a shunt in the form of a slip ring assembly should be incorporated. 2. Check all wiring, insulation and rotor windings to be sure that they are sound and all connections are properly made. 3. Where pumps are belt driven, consider the elimination of static charges by proper grounding or consider belt material that is less generative.
				●	<p>Bearing damage due to improper lubrication, identified by one or more of the following:</p> <ol style="list-style-type: none"> 1. Abnormal bearing temperature rise. 2. A stiff cracked grease appearance. 3. A brown or bluish discoloration of the bearing races. 	<ol style="list-style-type: none"> 1. Be sure the lubrication is clean. 2. Be sure proper amount of lubricant is used. The constant level oiler supplied with Durco pumps will maintain the proper oil level if lubricated bearings, be sure that there is space adjacent to the bearing into which it can rid itself of excessive lubricant, otherwise the bearing may overheat and fail prematurely 3. Be sure the proper grade of lubricant is used.

10 Decommissioning and Recommissioning

10.1 Decommissioning

Ensure all liquids are removed from the pump as followed:

1. Drain pump
2. Drain seal systems
3. Drain oil and or remove grease

After liquid has been drained follow long term storage procedures

10.2 Recommissioning

For products stored for 6 months follow short term Storage procedures, section 4.5.1, for more than 6 months follow Long term procedures, section 4.5.2.

See Section 6 for commissioning & Section 7 for Operations

11 Returns and Disposal

11.1 Returns

The product/system shall be emptied, cleaned, and preserved before returning the equipment to the manufacturer. The manufacturer will only open the returned equipment if the contamination declaration is present.

(Note: the terms and conditions associated with returning a product/system shall be addressed within the purchasing agreement or contract, and not part of the User Instruction.)

NOTICE

Contact Flowserve for return authorization. Any goods received without prior written authorization and proper documentation upon receipt will be return to the sender.

11.2 Disposal and recycling

At the end of the equipment service life of the product or its parts, the relevant materials and parts should be recycled or disposed of using local environmental regulation methods. If the product contains substances which are harmful to the environment, then the removal or disposal of the equipment must be in accordance with local/regional regulations. This includes any liquid and/or gas in the “seal system” or other utilities.



Refer to Safety Data Sheets and make sure that hazardous substances or toxic fluids are disposed of safely and that the correct personal protective equipment is used. All activities involving hazardous substances or toxic fluids must be in compliance with published safety standards.

12 Technical Data

12.1 Equipment dimensions and weights

Table 30: *Pump Weight* shows the approximant weights for Mark 3 Group 4 pump sizes. For the exact dimensions and weights of the product ordered, refer to the General Arrangement drawing included upon receiving the product.

Table 30: Pump Weight

Frame	Pump size	Impeller Dia. "Approx." Pump Weight kg (lb)
41K	12X10-16	605 (1325)
	14X14-16	715 (1570)
	8X4-19	450 (990)
	8X6-19	465 (1015)
	10X6-19	525 (1150)
	12X10-19	645 (1415)
	14X12-19	740 (1625)
42K	10X8-19	600 (1320)
	16X16-19	950 (2080)
	12X8-22	720 (1580)
	12X10-22	785 (1720)
	14X12-22	895 (1960)
	16X14-22	1040 (2280)

12.2 Nameplate

An example of the name plate is shown in Figure 57. For more details on nameplate, see the Declaration of Conformity or separate documentation included with these User Instructions.



Figure 57: Nameplate

12.2.1 Nomenclature

The pump size will be engraved on the nameplate typically as shown below. See section 12.2, Nameplate.

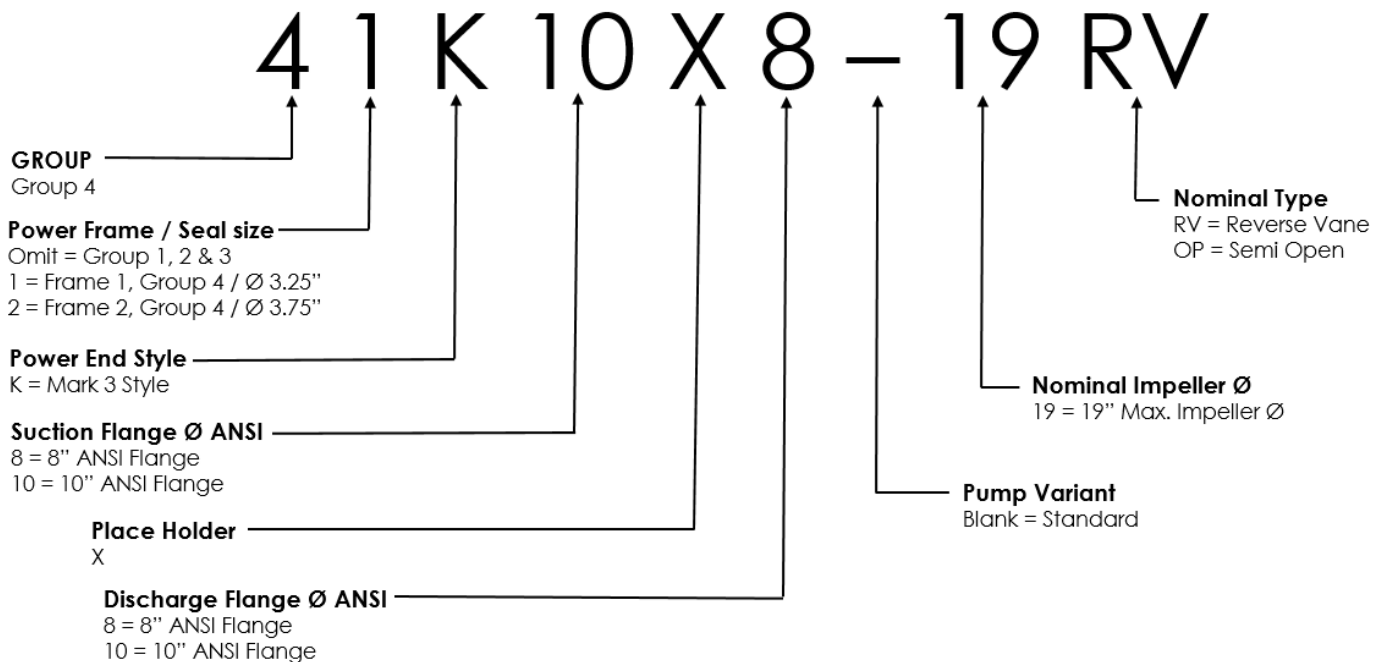

12.3 Operating limits

Refer to Section 7.2 for operating limits.

12.4 Torque requirements

Refer to Section 8.5, Table 21: *Torque Requirements*, for torque values.

12.5 Noise level

Attention must be given to the exposure of personnel to the noise. Local legislation will define when guidance to personnel on noise limitation is required, and when noise exposure reduction is mandatory. This is typically 80 to 85 dBA.

The usual approach is to control the exposure time to the noise or to enclose the machine to reduce emitted sound. The customer may have already specified a limiting noise level when the equipment was ordered, however if no noise requirements were defined, then attention is drawn to the following table to give an indication of equipment noise level so that the end-user can take the appropriate action in the plant, or site of operation.

Pump noise level is dependent on a number of operational factors, flow rate, pipework design and acoustic characteristics of the building, and so the values given are subject to a 3 dBA tolerance and cannot be guaranteed.

Similarly, the motor noise assumed in the “pump and motor” is that typically expected from standard and high efficiency motors when on load directly driving the pump. Note that a motor driven by an inverter may show an increased noise at some speeds.

If a pump unit only has been purchased for fitting with your own driver, then the “pump only” noise levels in the table should be combined with the level for the driver obtained from the supplier. Consult Flowserve or a noise specialist if assistance is required in combining the values.

It is recommended that where exposure approaches the prescribed limit, then site noise measurements should be made.

The values are sound pressure level L_{pA} at 1 m (3.3 ft) from the machine, for “free field conditions over a reflecting plane”.

For estimating sound power level L_{WA} (re 1 pW) then add 14 dBA to the sound pressure value.

Table 31: Noise Levels

Motor size and speed kW (hp)	Typical sound pressure level L_{pA} at 1 m reference 20 μ Pa, dBa											
	60 Hz						50 Hz					
	1 780 r/min		1 180 r/min		885 r/min		1 480 r/min		980 r/min		740 r/min	
	Pump only	Pump and motor	Pump only	Pump and motor	Pump only	Pump and motor	Pump only	Pump and motor	Pump only	Pump and motor	Pump only	Pump and motor
15 (20)	70	71	68	68	64	66	69	69	66	66	61	64
18.5 (25)	71	71	69	69	65	67	70	71	67	68	63	65
22 (30)	71	71	69	70	67	69	70	71	68	68	65	67
30 (40)	73	73	71	71	69	70	72	73	70	70	67	69
37 (50)	73	74	71	72	69	70	72	73	70	71	67	70
45 (60)	76	76	74	75	71	72	75	76	73	73	69	71
55 (75)	76	76	74	75	72	73	75	76	73	74	69	72
75 (100)	77	78	75	77	72	74	76	77	74	75	70	74
90 (125)	78	79	75	78	73	75	76	78	74	75	71	76
110 (150)	80	82	77	80	75	78	78	80	76	78	73	80
150 (200)	83	86	80	83	77	82	81	84	78	80	76	83
200 (270)	86	89	83	86	80	85	84	86	81	83	79	86
250 (335)	87	90	84	87	81	86	85	87	83	85	-	-
300 (400)	89	91	85	88	82	88	86	88	83	86	-	-
373 (500)	91	93	88	90	-	-	-	-	85	88	-	-
447 (600)	93	95	90	92	-	-	-	-	-	-	-	-
522 (700)	-	-	93	94	-	-	-	-	-	-	-	-

Notes:

1. Noise values provided are for reference and are not guaranteed
2. The suction and discharge piping has a significant impact on noise level
3. Noise levels provided are for clean water. Other fluids may impact noise levels
4. Motor driven by an inverter may show an increased noise at some speeds, up 15 dBa

12.6 Energy rating







The Mark 3 Group 4 is excluded from Title 10 Chapter II Subchapter D Part 431 Subpart Y-Pumps of the US Code of Federal Regulations (CFR)

The Department of Energy DOE Regulations Subpart Y applies to "Clean Water" pumps only. Excluded are:

1. Chemical process pump that meets the requirements of ANSI/ASME Standard B73.1–2012, "Specification for Horizontal End Suction Centrifugal Pumps for Chemical Process", and ANSI/ASME B73.2–2002, "Specifications for Vertical In-Line Centrifugal Pumps for Chemical Process"
2. International Organization for Standardization (ISO) 2858:1975, "End-suction centrifugal pumps (rating 16 bar) -- Designation, nominal duty point and dimensions" and ISO 5199:2002, "Technical specifications for centrifugal pumps -- Class II"

Annex A: Declaration of Conformity

If the product/system is being sold into a country which requires a Declaration of Conformity (DoC), an example of each DoC for the subject product/system must be included in this Annex.

 <div style="display: inline-block; vertical-align: middle; margin-left: 20px;">  </div> <p>Pump Division</p> <p>Flowserve Pumps Ltd., PO Box 17, Newark, Notts NG24 3EN, United Kingdom Tel: ++44 (0)1636 494600, Fax: ++44 (0) 1636 705991</p>
DECLARATION OF CONFORMITY
<p>Section 1.0. MACHINE DESCRIPTION</p> <p>Serial No Equipment/Item Purchase Order Model / Type Size  Hydro. Pressure Material Date DD/MM/YY Flow Head Speed Min-1 / RPM Motor, kW Hz Volts Amps Connection Country of Destination</p>
<p>Section 2.0. APPLICABLE DIRECTIVES / REGULATIONS</p> <ul style="list-style-type: none"> - Machinery Directive 98/37/EC Annex IIA - EMC Directive 89/336/EEC and 92/31/EEC - Low Voltage Directive 73/23/EEC, amended by 93/68 EEC. Only applicable to products with electrical devices with voltage input 50-1000 VAC and not applicable to hazardous areas to 94/9/EC (ATEX). - Explosive Atmospheres Directive 94/9/EC (ATEX). Only applicable when the  marking appears in section 1.0 <p>Equipment without the  marking must not be used in potentially explosive atmospheres.</p>
<p>Section 3.0. APPLICABLE STANDARDS / SPECIFICATIONS</p> <ul style="list-style-type: none"> - EN809:1998, EN953:1997, EN294:1992, ISO12100-1:2003, ISO12100-2:2003 - EN13463-1:2002, EN13463-5:2003, EN13463-6:2004, EN13463-8:2003 (when applies for compliance with 94/9/EC)
<p>Section 4.0. DECLARATION</p> <p>We, Flowserve Pumps Limited, at the above address, declare that under our sole responsibility for the supply of the machinery defined in SECTION 1.0 above, the said machinery complies with all the applicable Directives and Regulations set out in SECTION 2.0 above and with all the essential health and safety requirements applying to it when installed, operated and maintained in accordance with the applicable User Instruction manual(s).</p> <p>Signed:  Tom Momtsios, QA Chesapeake Operations</p>

DECLARATION OF CONFORMITY -CE.doc

Annex B: Technical Terms, Acronyms, and Abbreviations

1. Net positive suction head – available (NPSH_A)
 - a. The measure of the energy in a liquid above the vapor pressure. It is used to determine the likelihood that a fluid will vaporize in the pump. It is critical because a centrifugal pump is designed to pump a liquid, not a vapor.
 - b. Vaporization in a pump will result in damage to the pump, causing deterioration in Total Differential Head (TDH), vibration and possibly a complete stopping of pumping. Vaporization is synonymous with cavitation.
2. Net positive suction head – required (NPSH_R)
 - a. The fluid energy decreases between the inlet of the pump, and the point of lowest pressure in the pump. This decrease occurs because of friction losses and fluid accelerations. The total energy (NPSH) in the fluid is typically the lowest as fluid enters the impeller vanes. NPSH_R is the minimum required fluid energy need to maintain pumping.
 - b. The value for NPSH_R for the specific pump purchased is given in the pump data sheet, and on the pump performance curve. The value varies with flow.
 - c. For a pump to operate properly the NPSH_A must be greater than the NPSH_R. Good practice dictates that this margin is at minimum 1.5 m (5 ft) or 20%, whichever is greater.

NOTICE

Ensuring that NPSH_A is larger than NPSH_R by the suggested margin will greatly enhance pump performance, efficiency and reliability. It will also reduce the likelihood of cavitation, which can severely damage the pump.

3. Specific gravity (SG)
 - a. Pump capacity and total head in meter (feet) of liquid do not change with SG, however pressure displayed on a pressure gauge is directly proportional to SG. Power absorbed is also directly proportional to SG. It is therefore important to check that any change in SG will not overload the pump driver or over pressurize the pump.
4. Viscosity
 - a. For a given flow rate the total head reduces with increased viscosity. Also for a given flow rate the power absorbed increases with the increased viscosity, and reduces with reduced viscosity. Contact Flowserve if changes in viscosity are planned.
5. Pump speed
 - a. Changing the pump speed affects flow, total head, power absorbed, NPSH_R, noise and vibration levels. Flow varies in direct proportion to pump speed. Head varies as the speed ratio squared. Power varies as speed ratio cubed. If increasing speed, it is important to ensure that maximum pump working pressure is not exceeded, the driver is not overloaded, NPSH_A > NPSH_R and that noise and vibration are within local requirements and regulations.
6. Pumped flow
 - a. Flow must not fall outside the minimum and maximum continuous safe flows shown on the pump performance curve and or data sheet. Operate the pump between Minimum Continuous Stable Flow MCSF and End of Curve EOC.

Annex C: Additional Sources of Information

The following are excellent sources for additional information on Flowserve Mark 3 Group 4 pumps, and centrifugal pumps in general.

Pump Engineering Manual
R.E. Syska, J.R. Birk,
Flowserve Corporation, Irving, TX, 1994

Specification for Horizontal End Suction Centrifugal Pumps for Chemical Process, ASME B73.1
The American Society of Mechanical Engineers,
New York, NY.

American National Standard for Centrifugal Pumps for Nomenclature, Definitions, Design and Application (ANSI/HI 1.1 – 1.3)
Hydraulic Institute, 9 Sylvan Way, Parsippany,
New Jersey 07054-3802.

American National Standard for Centrifugal Pumps for Installation, Operation, and Maintenance (ANSI/HI 1.4)
Hydraulic Institute, 9 Sylvan Way, Parsippany,
New Jersey 07054-3802

Recommended Practice for Machinery Installation and Installation Design (API 686 2nd Edition, 2009)
American Petroleum Institute, 1220 L Street, NW, Washington, D.C. 20005

Flowserve Mark 3 Group 4 Sales Bulletin.

RESP73H Application of ASME B73.1 - 2012, Specification for Horizontal End Suction Centrifugal Pumps for Chemical Process, Process Industries Practices
Construction Industry Institute, The University of Texas at Austin, 3208 Red River Street, Suite 300,
Austin, Texas 78705

Pump Handbook
4th Edition, Igor J. Karassik et al, McGraw-Hill, Inc.,
New York, NY, Copyright 2008

Centrifugal Pump Sourcebook
John W. Dufour and William E. Nelson,
McGraw-Hill, Inc., New York, NY, Copyright 1993



Pumping Manual, 9th edition
T.C. Dickenson, Elsevier Advanced Technology,
Kidlington, United Kingdom, Copyright 1995

Annex D: Supplementary User Instructions

Supplementary instructions such as for a driver, coupling, instrumentation, controller, seals, seal systems are provided as separate documents in their original format. If further copies of these are required they should be obtained from the supplier for retention with these User Instructions.



NOTES:





NOTES:



Flowserve factory contacts:

**Flowserve Pump Division
3900 Cook Boulevard
Chesapeake, VA 23323-2626 USA**

Telephone +1 757 485 8000
Fax +1 757 485 8149

FLOWSERVE REGIONAL SALES OFFICES:

USA and Canada

Flowserve Corporation
5215 North O'Connor Blvd.,
Suite 300
Irving, Texas 75039-5421 USA
Telephone +1 972 443 6500
Fax +1 972 443 6800

Europe, Middle East, Africa

Flowserve FSG – Italy
Worthington S.r.l.
Via Rossini 90/92
20033 Desio (Milan) Italy
Telephone +39 0362 6121
Fax +39 0362 628 822

Asia Pacific

Flowserve Pte. Ltd
10 Tuas Loop
Singapore 637345
Telephone +64 6771 0600
Fax +65 6862 2329

Latin America and Caribbean

Flowserve Corporation
6840 Wynnwood Lane
Houston, Texas 77008 USA
Telephone +1 713 803 4434
Fax +1 713 803 4497

Flowserve Corporation has established industry leadership in the design and manufacture of its products. When properly selected, this Flowserve product is designed to perform its intended function safely during its useful life. However, the purchaser or user of Flowserve products should be aware that Flowserve product might be used in numerous application under a wide variety of industrial service conditions. Although Flowserve can (and often does) provide general guidelines, it cannot provide specific data and warnings for all possible applications. The purchaser/user should read and understand the User Instructions: Installation Operation Maintenance included with the product, and train its employees and contractors in the safe use of Flowserve products in connection with its application

While the information and specifications contained in this literature are believed to be accurate, they are supplied for informative purpose only and should not be considered certified or as a guaranteed of satisfactory results by reliance thereon. Nothing contained herein is to be construed as a warranty or guarantee, express or implied, regarding any matter with respect to the product. Because Flowserve is continually improving and upgrading its product design, the specifications, dimensions and information contained herein are subject to change without notice. Should any question arise concerning these provisions, the purchaser/user should contact Flowserve Corporation at any one of its worldwide operations or offices.

© 2017 Flowserve Corporation, Irving, Texas, USA. Flowserve is a registered trademark of Flowserve Corporation