



HPX-V

ISO 13709/API 610 (OH3)

Vertical In-line Process Pump



Experience In Motion



Industry-leading performance in a compact footprint

The HPX-V vertical in-line pump from Flowserve is more than just a space-saving alternative to many horizontal process pumps in upstream and downstream services. Based on the widely used Flowserve HPX horizontal process pump — a long-time workhorse of the oil and gas industry — the HPX-V vertical in-line pump offers you many of the same industry-leading benefits:

- Robust construction that meets or exceeds ISO 13709/API 610 (OH3) ensures you will have safe, reliable performance in high-temperature and high-working pressure applications.
- Stringent emissions containment is achieved with an ISO 21049/API 682-compliant seal chamber, which accommodates all seal models and styles, including advanced gas barrier seal technology.
- A comprehensive range of configurations and hydraulic coverage enables precise selection for best operating efficiency.
- Parts interchangeability with the HPX horizontal pump enables you to reduce parts inventory and carrying costs.
- Back pullout design simplifies maintenance activities and reduces associated costs.



Built for tough applications

The HPX-V vertical in-line process pump is engineered to reliably withstand the high pressures and temperatures often found in the oil and gas and hydrocarbon industries.

Typical applications

- Petroleum refining, production and distribution
- Petrochemical and chemical processing
- Gas industry services
- Biofuels
- High-temperature applications
- Boiler circulation
- Water
- General industrial

Operating parameters

- Flows to 1200 m³/h (5200 gpm)
- Heads to 325 m (1070 ft)
- Standard pressures to 42 bar (600 psi)
- Temperatures from -40°C to 400°C (-40°F to 750°F)

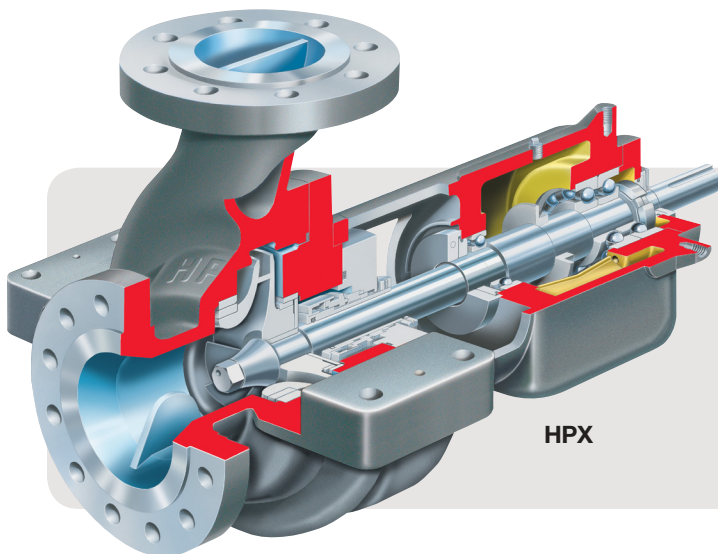

Cost savings from parts interchangeability

The HPX-V pump uses the same impeller, wear rings and bearings as the HPX horizontal pump. It also has the same shaft diameter under its seal. These enable you to standardize parts between the pump lines, reducing spare parts inventories.

Process pump performance in a space-saving design

The HPX-V vertical inline process pump allows you to save space without giving up performance. Its rugged ISO 13709/API 610 (OH3) construction and compact footprint make it ideal for high-pressure, high-temperature applications where installation space is limited.



Features and benefits

In-line vertical casing withstands nozzle loads per ISO 13709/API 610 requirements to minimize shaft misalignment and extend rotor, bearings and seal life.

Raised face flanges are to ASME B16.5 criteria for Class 300. Surface finish meets ISO 13709/API 610 standard. ISO and JIS flanges are available.

Casing and cover feature a metal-to-metal fit with a fully confined controlled compression gasket to ensure proper sealing and alignment.

Suction nozzle guide vane reduces inlet vortexing and ensures a reliable NPSH margin.

Dynamically balanced precision cast impeller minimizes vibration to ensure smooth operation over a wide flow range.

Renewable casing and impeller wear rings reduce parts costs. Back wear ring is standard on all pump sizes. Optional arrangements and materials available.

ISO 21049/API 682 seal chamber accommodates a wide variety of seals, including dual pressurized and unpressurized cartridge types for the most severe services. A full complement of API 682 seal flush piping plans is available.

Shaft design is well within ISO/API shaft deflection and run-out criteria.

Reliability, maintenance and safety-enhancing design

- **Cartridge seal mounting** assures ease of maintenance and precise seal face setting for maximum seal life.
- **Dynamically balanced impeller** limits vibration and assures smooth operation over a wide flow range.
- **Positively locked** anti-rotation impeller nut avoids erroneous operation.
- **Standardized mounting plate** is provided to maintain the API 3:1 ratio from the unit center of gravity to prevent tipping.
- **Optional larger mounting plates** accommodate mounting of seal pot assemblies and heat exchangers.
- **Back pullout** rotating assembly simplifies maintenance, as neither the motor nor piping connections are disturbed.
- **Coupling guard** is provided to enclose the coupling, pump shaft and motor shaft areas.
- **Renewable wear rings** for both casing and impeller reduce replacement parts costs. Wear rings are secured by axial screws as standard; tack welding optional.

Heavy-duty bearing system

The bearing housing of the HPX-V is made of heavy-duty carbon steel. Standard labyrinth-type oil seals retain oil and exclude atmospheric contaminants and moisture. Optional bearing isolators are available. Oil sump bearing is cooled using standard fan air cooling.

Bearing size selection is standardized together with the HPX (OH2) overhung horizontal process pump line to maximize spare parts availability.

Choice of bearing lubrication:

- Oil cascade lube design for temperatures to 385°C (725°F)
- Oil mist design for temperatures to 400°C (750°F)
- Grease lube design for temperatures to 275°C (525°F)

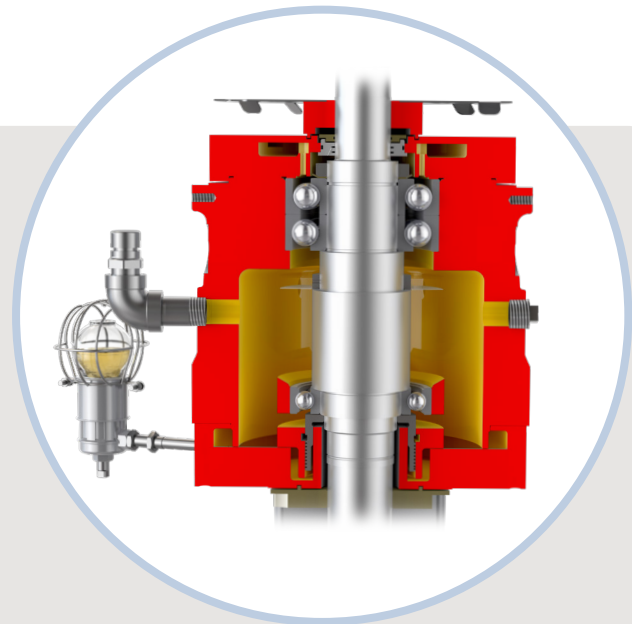

Special configurations



HPXM-V – low flow and high head

With a Barske-style, multiple radial blade impeller and a volute insert, the HPXM-V provides best efficiency point hydraulic fits. It delivers a performance curve continuously rising to minimum flow in low-flow and high-head applications.

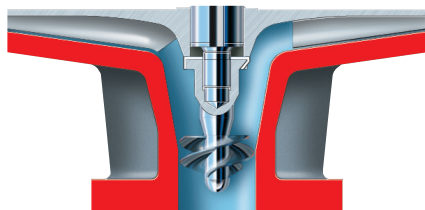

HPX-V-IND – inducer

For applications with low NPSHa, the HPX-V can be fitted with an inducer. This high suction-specific speed, axial flow pumping device provides significant improvement in suction performance by reducing pump NPSHr.

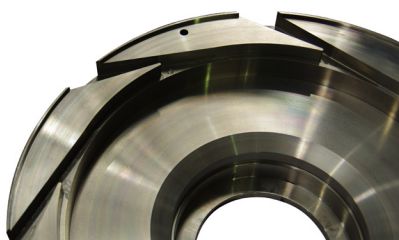

HPXD-V – milled diffuser

Design for customized BEP fits, the HPXD-V provides low vibration level at any flow, minimum continuous flows at 10–20% of BEP, and very low shaft deflection and virtually zero radial hydraulic thrust at any flow rate.

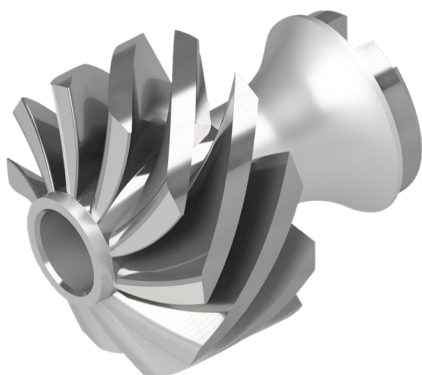

HPX-V-CC – coke crusher

Incorporating a special cutter screw, the HPX-V-CC facilitates the handling of coke particles in suspension. By reducing their sizes, the cutter screw enables the coke particles to easily pass through the impeller.

Hydraulic coverage

Two-pole

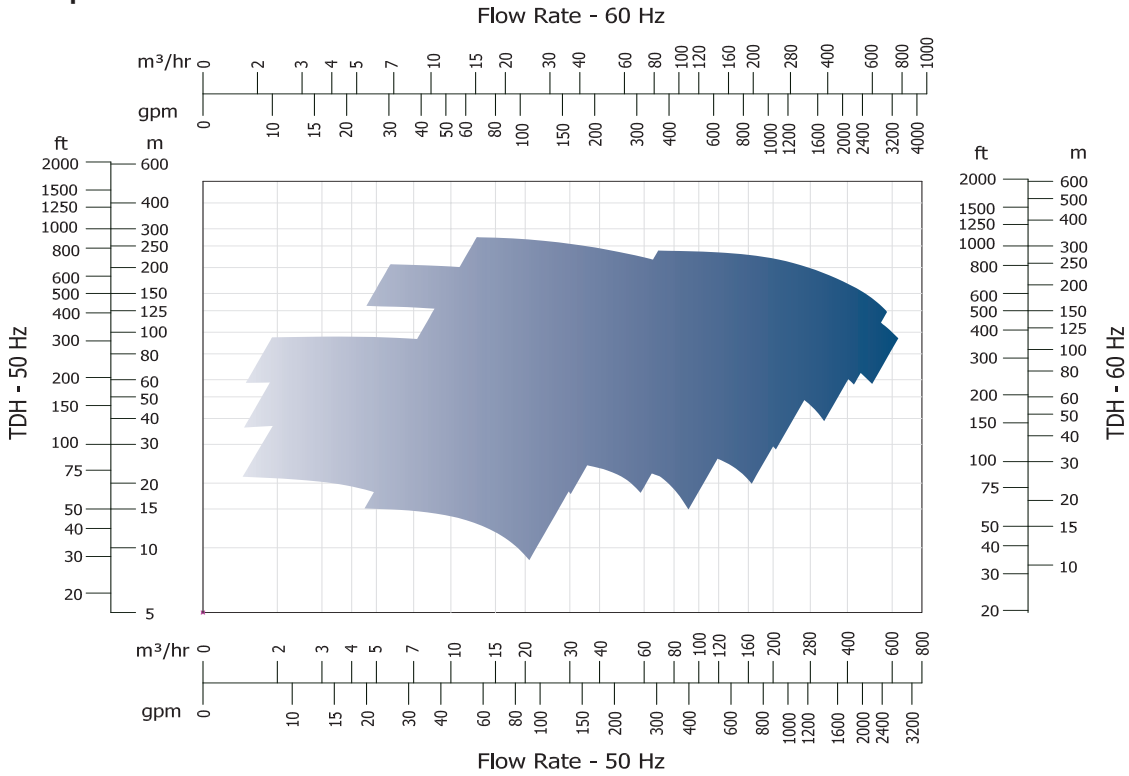

Four-pole

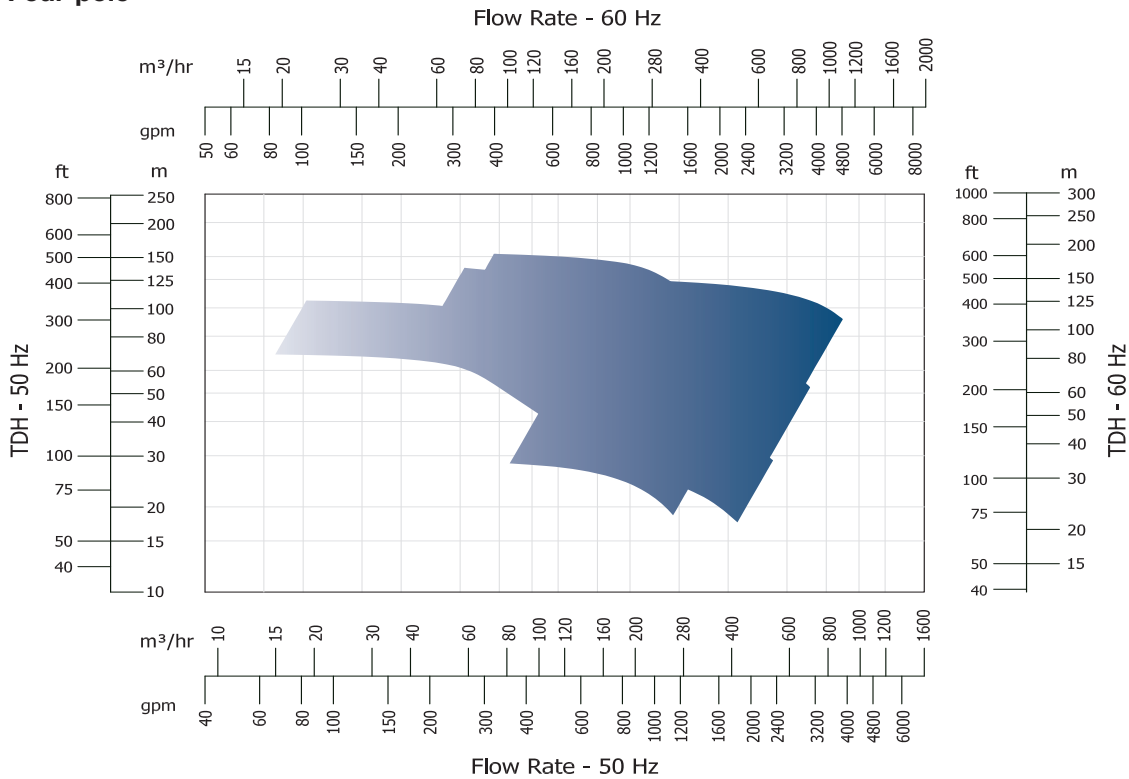



Flowserve Corporation
5215 North O'Connor Blvd.
Suite 2300
Irving, Texas 75039-5421 USA
Telephone: +1 937 890 5839

PS-10-43 (E) February 2019

Flowserve Corporation has established industry leadership in the design and manufacture of its products. When properly selected, this Flowserve product is designed to perform its intended function safely during its useful life. However, the purchaser or user of Flowserve products should be aware that Flowserve products might be used in numerous applications under a wide variety of industrial service conditions. Although Flowserve can provide general guidelines, it cannot provide specific data and warnings for all possible applications. The purchaser/user must therefore assume the ultimate responsibility for the proper sizing and selection, installation, operation, and maintenance of Flowserve products. The purchaser/user should read and understand the Installation Instructions included with the product, and train its employees and contractors in the safe use of Flowserve products in connection with the specific application.

While the information and specifications contained in this literature are believed to be accurate, they are supplied for informative purposes only and should not be considered certified or as a guarantee of satisfactory results by reliance thereon. Nothing contained herein is to be construed as a warranty or guarantee, express or implied, regarding any matter with respect to this product. Because Flowserve is continually improving and upgrading its product design, the specifications, dimensions and information contained herein are subject to change without notice. Should any question arise concerning these provisions, the purchaser/user should contact Flowserve Corporation at any one of its worldwide operations or offices.

©2019 Flowserve Corporation. All rights reserved. This document contains registered and unregistered trademarks of Flowserve Corporation. Other company, product, or service names may be trademarks or service marks of their respective companies.