



# *Kämmer® HpFlow™ - 011000, 015000*

## *High Pressure Valves*



*Experience In Motion*

***HpFlow™ - 011000, 015000***

**Description**

High pressure angle valves with split body. Connections manufactured to IG standards. Other high pressure screwed connections or flanges are possible. These valves provide a basis for high pressure relief special designs e.g. with wear bushes, dissipator sleeves, additional aperture plates. Furthermore, due to their unique construction, they can be manufactured from almost any desired material.

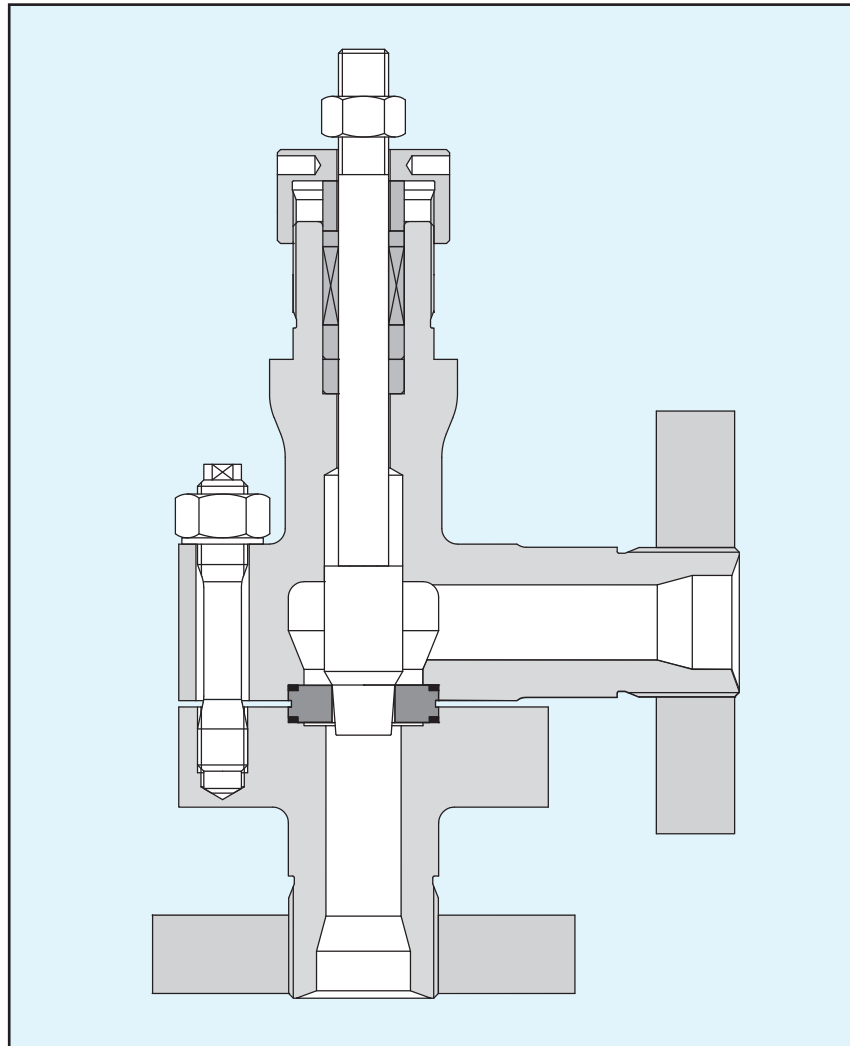

Standard valve with flange connections

# HpFlow™ - 011000, 015000

## Technical Data

Series	011000	015000
Valve body style	Angle	
Characteristics	Equal%, Linear, On-Off	
Seat leakage, standard	≤ 0.01 of C <sub>vs</sub> value	
Material for plug/seat ring	316Ti Optional: 1.4122, Stellite ceramics, tungsten carbide	316Ti Optional: Alloy 6, Hastelloy C titanium, ceramics, tungsten carbide
PTFE-soft seat T = max. 150 °C (300 °F)	In seat ring C <sub>vs</sub> 0.12 – 2.9 for tighter seating	In plug from C <sub>vs</sub> 1.2 for tighter seating
Packing	PTFE for temperatures up to +200 °C (392 °F) Grafoil for temperatures over +200 °C (392 °F) PTFE for oxygen services Packing according to German clean air act (TA-Luft)	
Body gaskets	PTFE for temperatures from up to +200 °C (392 °F) 316Ti for temperatures over +200 °C (392 °F)	
Extensions	Standard, normalizing fins, bellows seal, cryogenic	
C <sub>vs</sub> values	See tables pages 6/7	
Connections	Screwed internal* DN 3 - 10, PN 325 - 4000 Screwed flanges acc. to IG Std. NW 3-16, ND 325-700 ANSI-flanges ½", Class 1500 - 2500	Screwed flanges acc. to IG Std. NW 16-45, ND 325-700 ANSI-flanges 1" - 2", Class 1500 - 2500
Valve body	316Ti, WNR 1.4429 Optional: Hastelloy C or other materials according to pressure rating	

\* Manufactured according to customers requirements; suitable for superpressure connectors.

**HpFlow™ - 011000, 015000**

**Designs**

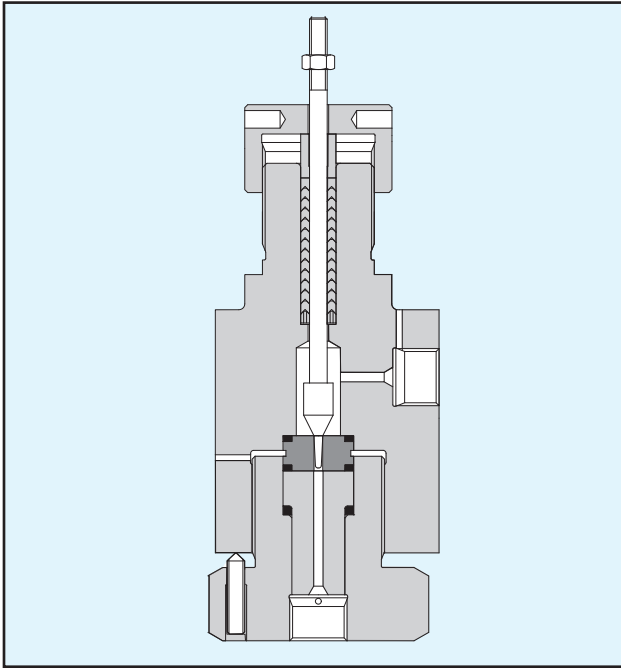

Super pressure valve PN 4000 (60 000 lbs)

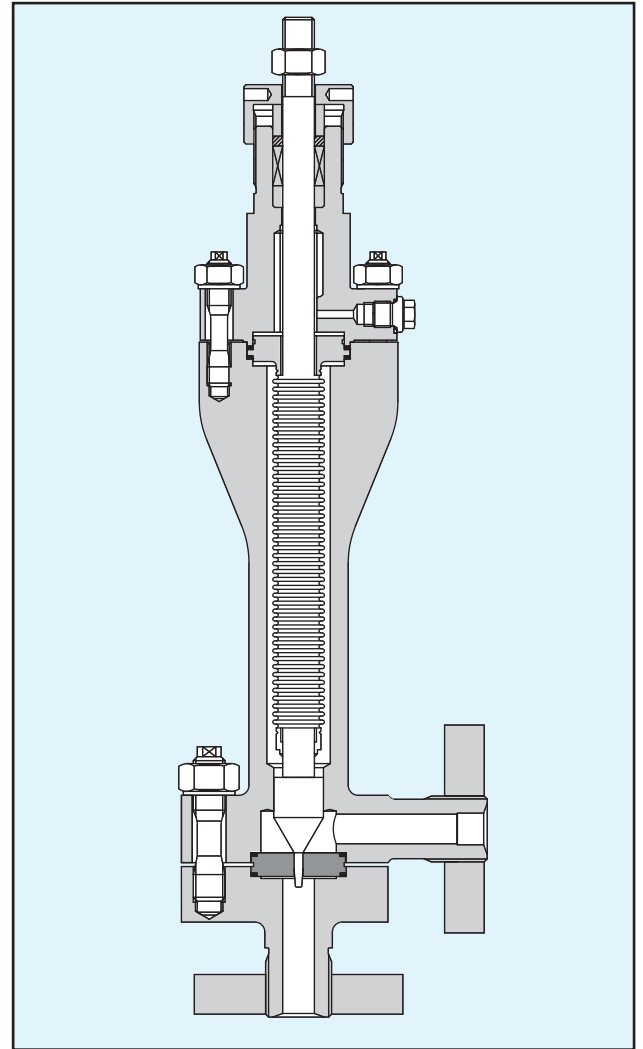

Valve with bellows seal

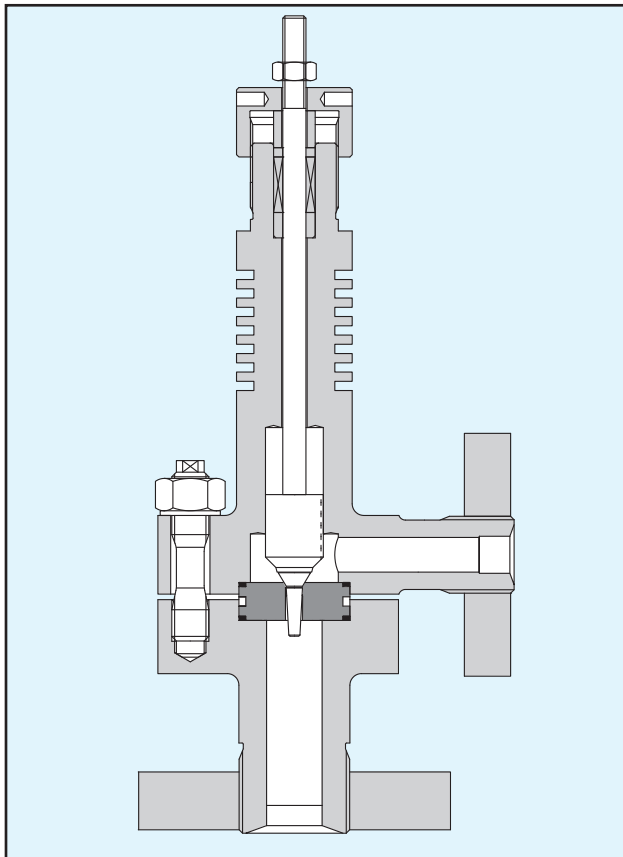

Valve with normalizing fins -30 to 0 °C (-22 to 32 °F)  
resp. 250 to 400 °C (482 to 750°F)

# HpFlow™ - 011000, 015000

## Designs

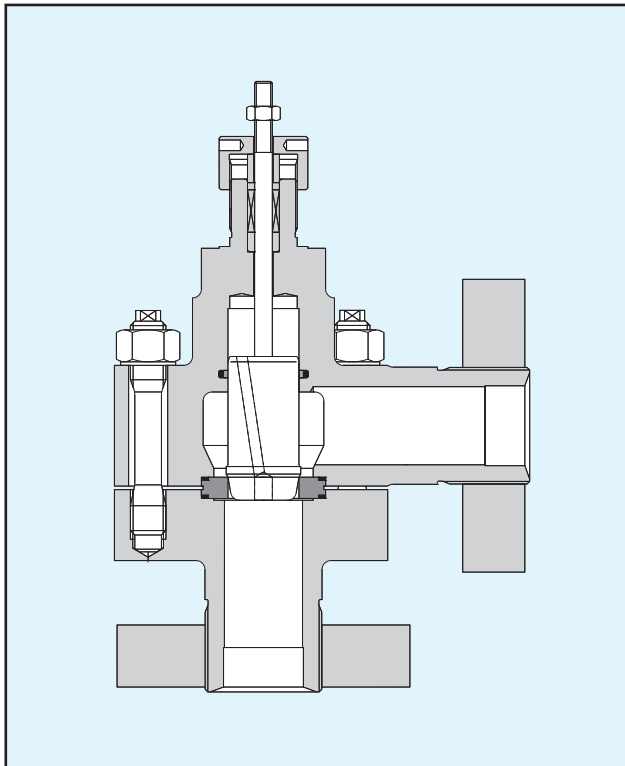

Valve with partially balanced plug

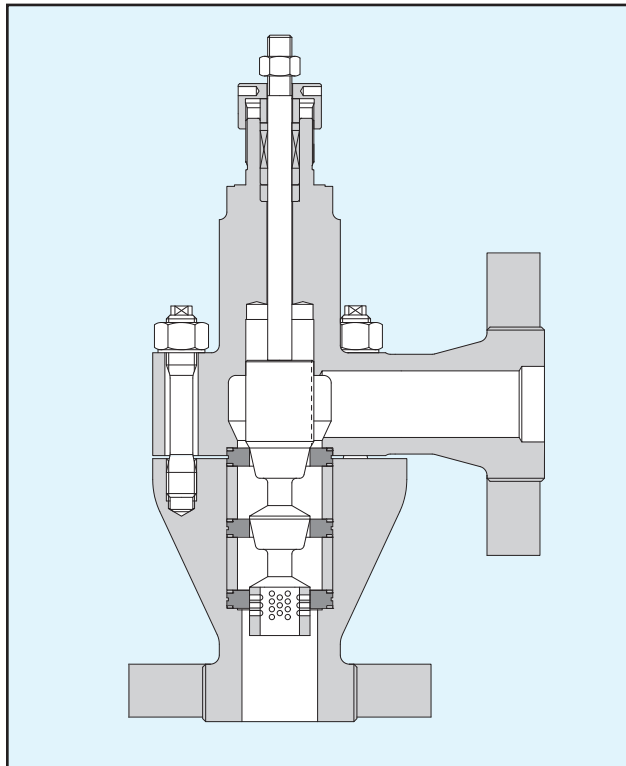

Multi-stage high pressure letdown valve for low noise and reduced wear

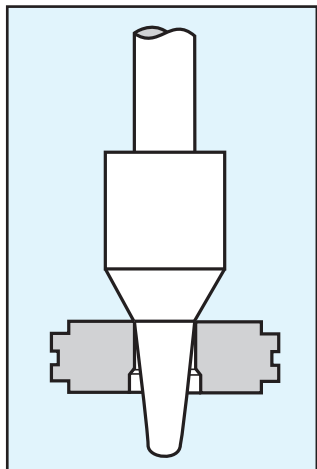

Standard trim

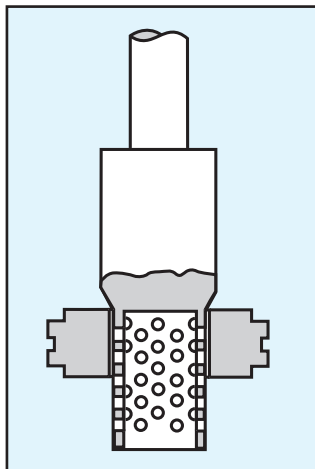

Low noise cage trim

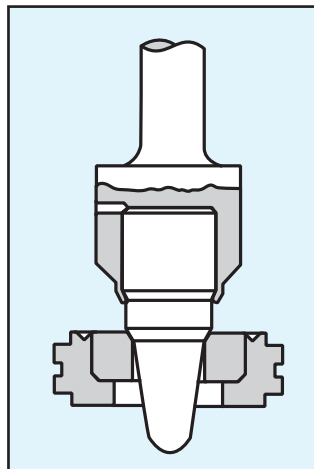

Ceramics or tungsten carbide plug tip and seat insert

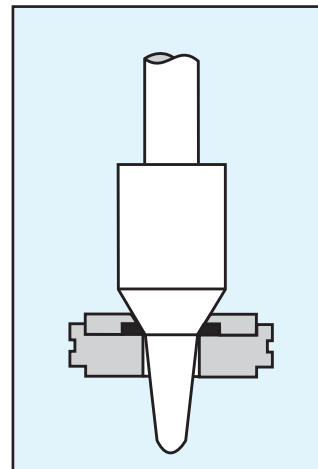

Trim with PTFE soft seat for temperatures up to +150 °C (300 °F) (series 011000)

# HpFlow™ - 011000, 015000

## Standard C<sub>vs</sub> Values Series 011000

Size NW	3	6	10	16	C <sub>vs</sub> -value (Turbulent)*	Seat diameter mm (in.)	Rangeability**	Plug material, standard	Seat material, standard	Characteristics, lin	Characteristics, gl	Alternative materials for seat/plug	
												Tungston carbide; Hastelloy C	Nickel; Monel; Titanium; Alloy 6
Stroke mm (in.)	10 (0.39)	10 (0.39)	10 (0.39)	10 (0.39)									
Stem diameter mm (in.)	6 (0.24)	6 (0.24)	6 (0.24)	6 (0.24)									
					0.000063	2 (0.08)	25:1	Alloy 6	1.4122	-	X	-	-
				0.000079	-					X	-	-	
				0.000098	-					X	-	-	
				0.00012	-					X	-	-	
				0.00015	-					X	-	-	
				0.00019	-					X	-	-	
				0.00023	-					X	-	-	
				0.00029	-					X	-	-	
				0.00036	-					X	-	-	
				0.00045	-					X	-	-	
				0.00056	-					X	X	-	
				0.00075	-					X	X	-	
				0.00098	-					X	X	-	
				0.0013	-					X	X	-	
				0.0017	-					X	X	-	
				0.0022	-					X	X	-	
				0.0029	-					X	X	-	
				0.0038	-					X	X	-	
				0.0054	-					X	X	-	
				0.0079	-					X	X	-	
				0.013	3 (0.12)	50:1	1.4571	X	X	X	X		
				0.020				X	X	X	X		
				0.029				X	X	X	X		
				0.047				X	X	X	X		
				0.074				X	X	X	X		
				0.12				X	X	X	X		
				0.19				X	X	X	X		
				0.29				X	X	X	X		
				0.47				X	X	X	X		
				0.74				X	X	X	X		
				1.2	7	X	X	X					
				1.9	(0.28)	X	X	X					
				2.9	10 (0.39)	X	X	X					

\* Further special C<sub>vs</sub> values on request.

\*\*For calibrating conditions

### Valve Code

0 1 1 0 P 3

Body type		
	Series	
011	Angle valve	011 000
015	Angle valve	015 000

Bonnet	
0	Standard
1	Normalizing fins
3	Bellows seal
5	Cryogenic extension

Actuator	
H3, H4, H5	Manual handwheel
P2, P3 P4, P5	Pneumatic, series 2
37, 38 39, 3D	Pneumatic, series 4 with integral positioner
E2, E3 E4, E5	Electric

# HpFlow™ - 011000, 015000

## Standard C<sub>vs</sub> Values Series 015000

Size NW	16	24	30	45	C <sub>vs</sub> value *	Seat diameter mm (in.)	Rangeability**	Seat material (standard)	Plug material (standard)
Size DIN / ANSI	-	-	25/1"	50/2"					
Stroke mm (in.)	20 (0.79)	20 (0.79)	20 (0.79)	20 (0.79)					
Stem diameter*** mm (in.)	10 (0.39)	10 (0.39)	10 (0.39)	16 (0.63)					
					0.12	4.5 (0.18)	50:1	1.4571	1.4571
					0.19	4.5 (0.18)			
					0.29	4.5 (0.18)			
					0.47	4.5 (0.18)			
					0.74	4.5 (0.18)			
					1.2	7.0 (0.28)			
					1.9	7.0 (0.28)			
					2.9	10 (0.39)			
					4.7	12 (0.47)			
					7.4	16 (0.63)			
					12	20 (0.79)			
					19	25 (0.98)			
					29	32 (1.26)			
					47	40 (1.57)			

\* Further special C<sub>vs</sub> values on request.

\*\* For calibrating conditions.

\*\*\* For thrusts ≥ 1000 daN stem diameter = 16 mm (0.63 in.)

## Dimensions mm (in.) and Weights kg (lb.)

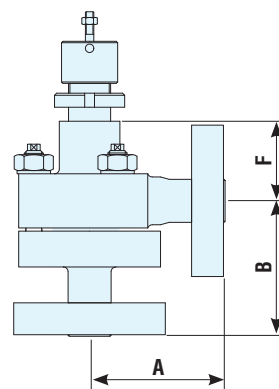

NW	Dimensions A/B			Height F			Weight			
	ND 325	ND 500	ND 700	Standard	Fins	Bellows	Standard	Fins	Bellows	
011000	3	85 (3.35)	85 (3.35)	85 (3.35)	-	-	-	4 (8.8)	4.5 (9.9)	7 (15.5)
	6	85 (3.35)	85 (3.35)	85 (3.35)	41 (1.61)	81 (3.19)	227 (8.94)	4 (8.8)	4.5 (9.9)	7 (15.5)
	10	85 (3.35)	85 (3.35)	85 (3.35)	41 (1.61)	81 (3.19)	227 (8.94)	5 (11.0)	5.5 (12.0)	8 (17.6)
	16	95 (3.74)	95 (3.74)	95 (3.74)	41 (1.61)	81 (3.19)	227 (8.94)	6 (13.2)	6.5 (14.3)	9 (19.8)
015000	16	95 (3.74)	95 (3.74)	95 (3.74)	80 (3.15)	140 (5.51)	294 (11.57)	8 (17.6)	9 (19.8)	18 (39.7)
	24	110 (4.33)	110 (4.33)	120 (4.72)	75 (2.95)	135 (5.31)	289 (11.38)	12 (26.5)	13 (28.7)	22 (48.5)
	30	120 (4.72)	120 (4.72)	-	72 (2.83)	132 (5.20)	286 (11.26)	14 (30.9)	15 (33.0)	24 (62.9)
	45	150 (5.90)	-	-	145 (5.71)	145 (5.71)	301 (11.85)	23 (50.7)	25 (55.1)	32 (70.5)



Your contact:



FCD KMENBR1120-00 02/10

Flowserve Corporation has established industry leadership in the design and manufacture of its products. When properly selected, this Flowserve product is designed to perform its intended function safely during its useful life. However, the purchaser or user of Flowserve products should be aware that Flowserve products might be used in numerous applications under a wide variety of industrial service conditions. Although Flowserve can (and often does) provide general guidelines, it cannot provide specific data and warnings for all possible applications. The purchaser/user must therefore assume the ultimate responsibility for the proper sizing and selection, installation, operation, and maintenance of Flowserve products. The purchaser/user should read and understand the Installation Operation Maintenance (IOM) instructions included with the product, and train its employees and contractors in the safe use of Flowserve products in connection with the specific application.

While the information and specifications contained in this literature are believed to be accurate, they are supplied for informative purposes only and should not be considered certified or as a guarantee of satisfactory results by reliance thereon. Nothing contained herein is to be construed as a warranty or guarantee, express or implied, regarding any matter with respect to this product. Because Flowserve is continually improving and upgrading its product design, the specifications, dimensions and information contained herein are subject to change without notice. Should any question arise concerning these provisions, the purchaser/user should contact Flowserve Corporation at any one of its worldwide operations or offices.

© 2000 Flowserve Corporation, Irving, Texas, USA. Flowserve is a registered trademark of Flowserve Corporation.

## Worldwide Regional Headquarters

### Flowserve Corporation

Flow Control  
1350 N. Mt. Springs Parkway  
Springville, UT 84663  
USA  
Phone: +1 801 489 8611  
Fax: +1 801 489 3719

### Flowserve (Austria) GmbH

Control Valves - Villach Operation  
Kasernengasse 6  
9500 Villach  
Austria  
Phone: +43 (0)4242 41181 0  
Fax: +43 (0)4242 41181 50

### Flowserve India Controls Pvt. Ltd

Plot # 4, 1A, E.P.I.P, Whitefield  
Bangalore Kamataka  
India 560 066  
Phone: +91 80 284 10 289  
Fax: +91 80 284 10 286

### Kämmer Products

Europe, Middle East, Africa, Asia, Pacific

### Flowserve Essen GmbH

Manderscheidstr. 19  
45141 Essen  
Germany  
Phone: +49 (0)201 8919 5  
Fax: +49 (0)201 8919 662

### Kämmer Products

Americas

### Flowserve Pittsburgh

#### Kämmer Valves

1300 Parkway View Drive  
Pittsburgh, Pa 15205  
USA  
Tel.: +1 412 787 8803  
Fax: +1 412 787 1944