



HPX-Mag Magnetic Drive Process Pump

API 685 3rd Edition



Experience In Motion



Advanced sealless pump technology

The HPX-Mag magnetic drive process pump from Flowserve sets a new industry benchmark for magnetic drive pump value, efficiency and performance. It fully complies with API 685 standards and provides a zero-emissions solution for environmentally critical applications.

The HPX-Mag pump represents the most comprehensive range of hydraulic coverage available to the industry, so users can select the correct pump to meet their efficiency desires and application needs.



Based on proven API 610 design

The HPX-Mag pump is a horizontal, overhung, single-stage, radially split, end suction, top-discharge, centerline mounted pump with a high-efficiency magnetic coupling. It is based on the proven hydraulic design of the Flowserve HPX API 610 pump and delivers the following performance-enhancing features:

- Robust construction meets or exceeds API 685 requirements, ensuring zero emissions in difficult-to-seal, toxic, aggressive and flammable liquids.
- Hermetically sealed design eliminates the need for mechanical seals and external flushing systems.
- Dynamic thrust balancing system limits vibration and assures smooth operation over a wide flow range.
- Increased mean time between maintenance (MTBM) reduces downtime and maintenance costs.
- Back pullout design simplifies maintenance activities and reduces labor costs.
- Extensive hydraulic coverage enables precise selection for the highest operating efficiency.
- Parts interchangeability with HPX API 610 pump reduces parts inventory and carrying costs.

Eliminate leaks in aggressive and toxic applications

The HPX-Mag pump is designed to reliably withstand the high pressures, temperatures and aggressive media often found in the oil and gas and hydrocarbon industries.

Typical applications:

- Petroleum production, distribution and refining
- Petrochemical and chemical processing
- Difficult-to-seal liquids
- Toxic, aggressive or flammable liquids
- High-temperature applications
- Gas industry services
- Biofuels
- Boiler circulation
- Power plants
- General industrial

Operating parameters:

- Rated flows to 1,000 m³/h (4,400 gpm)
- Heads to 300 m (985 ft)
- Standard pressures to 42 bar (600 psi)
- Temperatures from -29°C to 300°C (-20°F to 570°F)*



**Higher pressures or temperatures available on request*

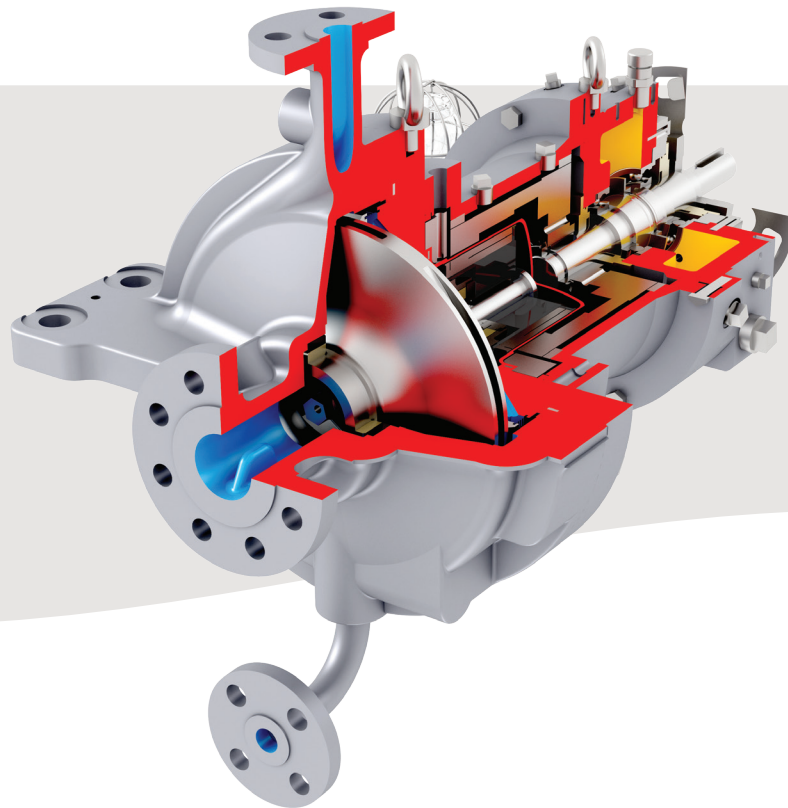

Efficiency, reliability and sustainability

The HPX-Mag sealless pump allows you to meet API 685 compliance standards without sacrificing performance or reliability. This versatile pump offers outstanding leakage protection and can handle toxic, aggressive or combustible liquids in compliance with environmental regulations on hazardous fluids.

Features and benefits

Internal flushing with process fluid cools the magnet area and lubricates the sleeve bearings. External flushing plans available upon request.

Leakage-free containment shell made from alloy C4 material for high-efficiency performance and high corrosion resistance. Ceramic ZrO_2 material containment shell is available for zero eddy current losses. Both containment shell designs are self-venting and fully drainable.

Lubricated radial and thrust bearings made of silicon carbide (SiC) material, mounted with tolerance fit compensate for expansion in high-temperature conditions. Optional materials are available for special application needs.

High-torque magnets made of rare earth samarium-cobalt eliminate slippage and enable high-temperature resistance.

Backup renewable rings made of non-sparking material protect the containment shell and prevent fluid leakage in case of a failure.

Consolidated hydraulic design uses the same casing and impeller installed in the popular HPX API 610 pump.

Back pullout design simplifies maintenance, as the motor and piping are not disturbed.

Centerline-supported pump casing withstands nozzle loads beyond API 685 design requirements. The suction nozzle guide vane reduces inlet vortexing and ensures uniform flow into the impeller to achieve a reliable NPSH margin.

Precision cast impeller is dynamically balanced to limit vibration and assure smooth operation over a wide flow range. It is secured by a set screw and a locknut, which are not exposed to the fluid.

Renewable casing and impeller wear rings reduce replacement parts costs. Wear rings are secured by set screws or tack welds.

Innovative thrust-balanced design

The HPX-Mag pump coupling design employs a dynamic thrust-balancing system. It eliminates the need for mechanical thrust bearings and increases pump reliability, longevity and efficiency while reducing operating costs.

Reduce maintenance labor and costs

The HPX-Mag pump offers a variety of features designed to simplify maintenance and reduce costs. These include:

- Standard back pullout simplifies general maintenance and inspections, as the casing stays in-line and the piping connections remain intact.
- The contained back pullout makes drive-end maintenance easy. The process fluid remains entirely confined, which eliminates the need to drain or purge the pump. Further, maintenance personnel aren't exposed to potentially harmful process fluids.
- Fully assembled replacement kits are available for all major components, including the impeller assembly, magnetic internal and external rotors, and bearings assembly.
- All silicon carbide components are 100% replaceable.

Heavy-duty bearing system

The HPX-Mag pump's bearing housing is constructed of heavy-duty carbon steel. Standard labyrinth-type oil seals retain oil and withstand atmospheric contaminants and moisture. Oil slinger lubrication reduces "dirty oil," ensuring bearings remain lubricated.

The HPX-Mag pump comes standard with two single-row, deep-groove radial bearings, but optional bearing isolators are also available.

Bearing lubrication and cooling options

Several different lubrication systems are available for the HPX-Mag pump, including:

- Oil mist and oil purge for continuous bearing lubrication
- Fan cooling for high operating or ambient temperature applications
- Finned cooling inserts for efficient water cooling, especially for hot standby applications

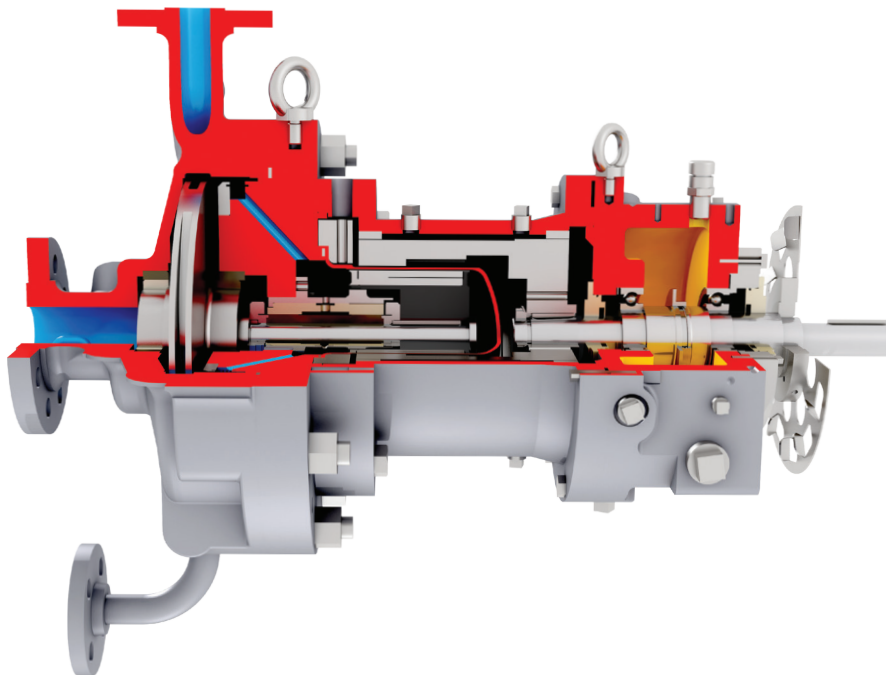

Optimized internal flushing path

The HPX-Mag pump features a highly engineered internal flushing path designed to efficiently cool the magnets and lubricate bearings.

The process fluid is fed from a high-pressure area behind the impeller to the magnetic coupling, and a self-cleaning filter is installed to prevent contamination.

The injected fluid is divided into two flow paths. The first path lubricates the bearings, creating a fluid film between the parts, while the second path cools the magnets, removing possible process particles from the end zone of the containment shell. Finally, fluid enters the lower-pressure area behind the impeller and flows back to the impeller vanes through the balancing holes.

The pressure difference between the inlet and outlet magnetic coupling chambers guarantees the correct flushing flow and prevents the vaporization of the product in the pump.

RVX-Mag pump retrofit available

The RVX-Mag back pullout assembly addresses users' needs for improved pump reliability with reduced maintenance costs. Based on the HPX-Mag pump design, the RVX-Mag back pullout assembly can be used to retrofit any existing overhung pump to meet API 685 requirements.

Many of the RVX-Mag and HPX-Mag components are interchangeable, further reducing inventory carrying costs.

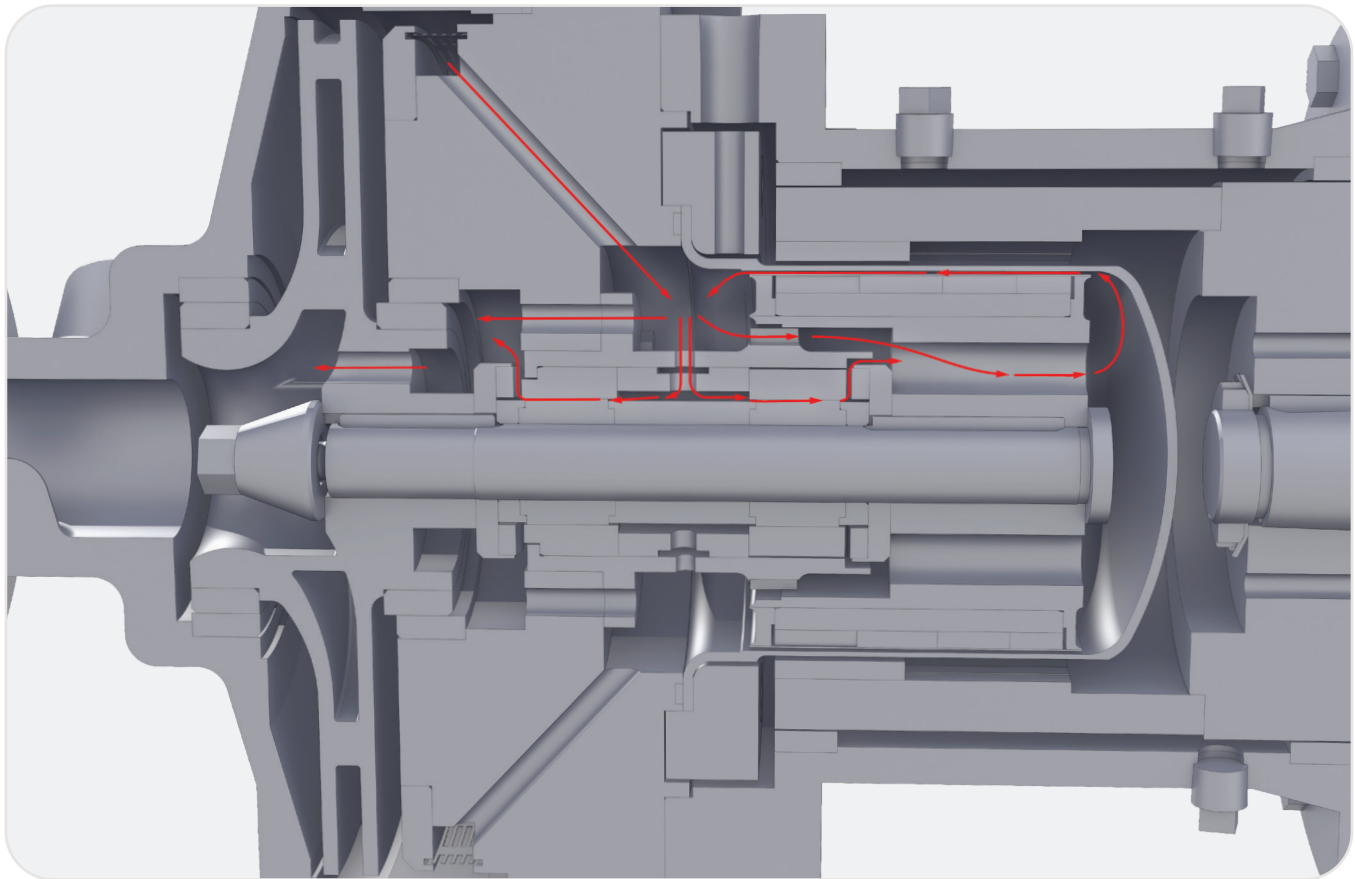

HPX-Mag internal flushing path

Hydraulic coverage

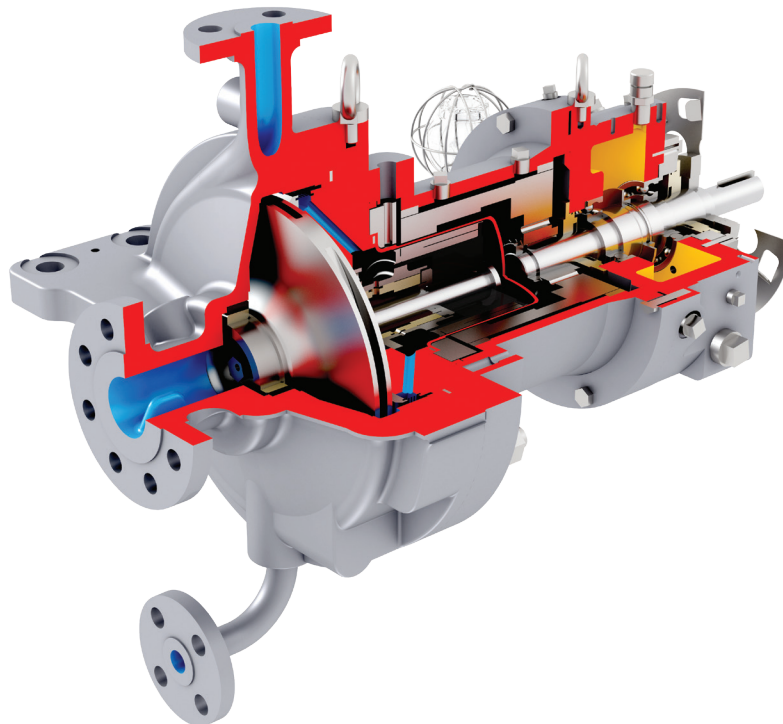
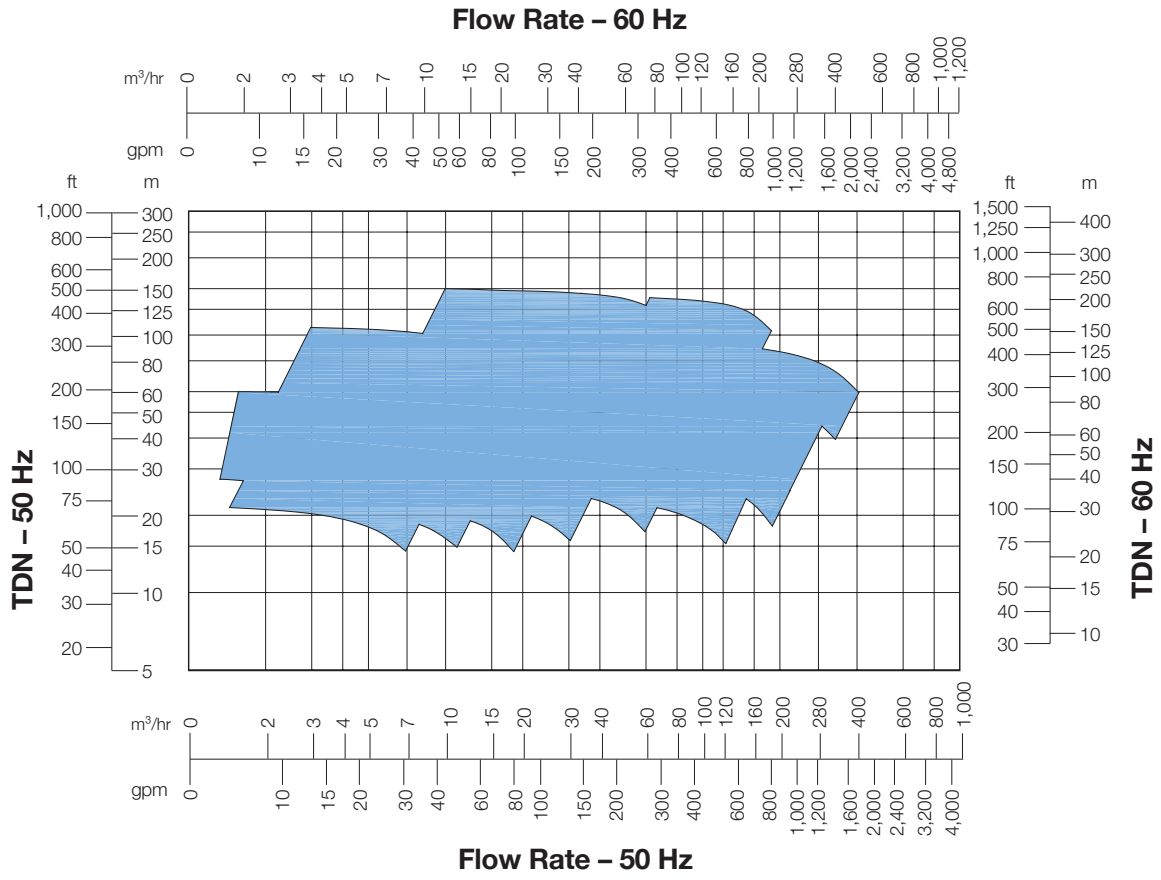



Flowserve Corporation
5215 North O'Connor Blvd.
Suite 700
Irving, Texas 75039-5421 USA

Flowserve Corporation has established industry leadership in the design and manufacture of its products. When properly selected, this Flowserve product is designed to perform its intended function safely during its useful life. However, the purchaser or user of Flowserve products should be aware that Flowserve products might be used in numerous applications under a wide variety of industrial service conditions. Although Flowserve can provide general guidelines, it cannot provide specific data and warnings for all possible applications. The purchaser/user must therefore assume the ultimate responsibility for the proper sizing and selection, installation, operation, and maintenance of Flowserve products. The purchaser/user should read and understand the Installation Instructions included with the product, and train its employees and contractors in the safe use of Flowserve products in connection with the specific application.

While the information and specifications contained in this literature are believed to be accurate, they are supplied for informative purposes only and should not be considered certified or as a guarantee of satisfactory results by reliance thereon. Nothing contained herein is to be construed as a warranty or guarantee, express or implied, regarding any matter with respect to this product. Because Flowserve is continually improving and upgrading its product design, the specifications, dimensions and information contained herein are subject to change without notice. Should any question arise concerning these provisions, the purchaser/user should contact Flowserve Corporation at any one of its worldwide operations or offices.

©2023 Flowserve Corporation. All rights reserved. This document contains registered and unregistered trademarks of Flowserve Corporation. Other company, product, or service names may be trademarks or service marks of their respective companies.

PUBR000077-05 (EN/AQ) July 2023