

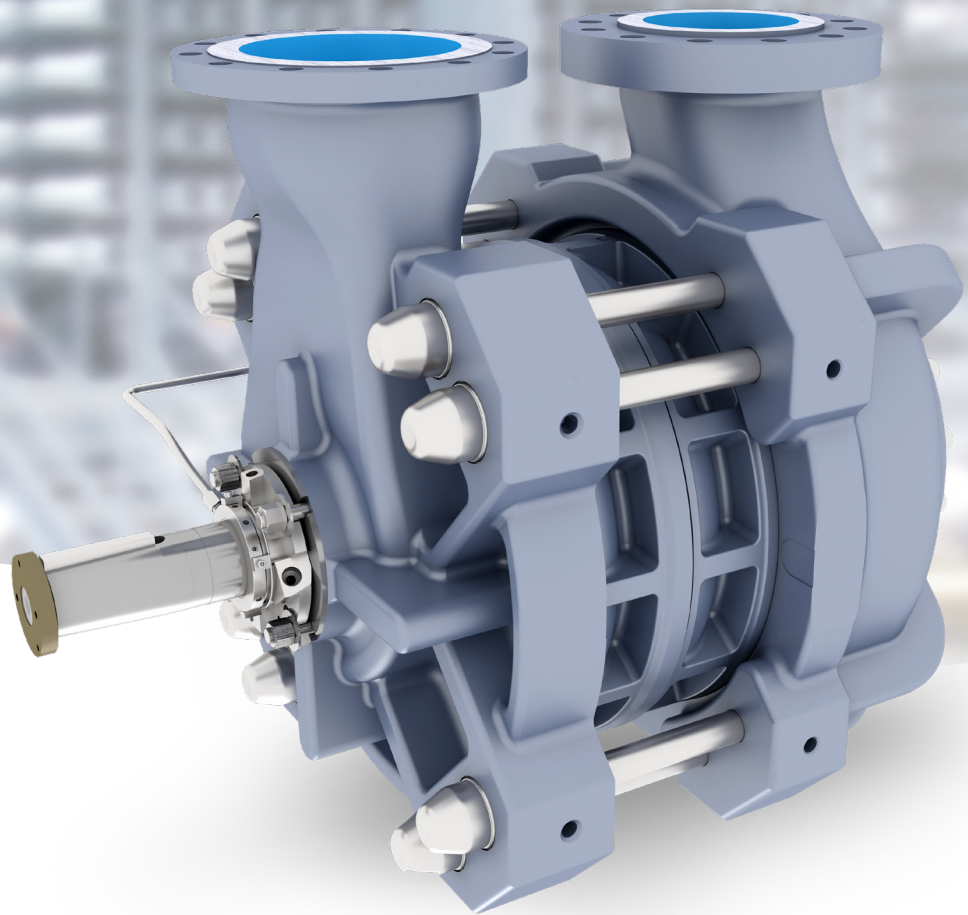

CSX

**High-efficiency membrane feed pump for
seawater reverse osmosis desalination**



Experience In Motion

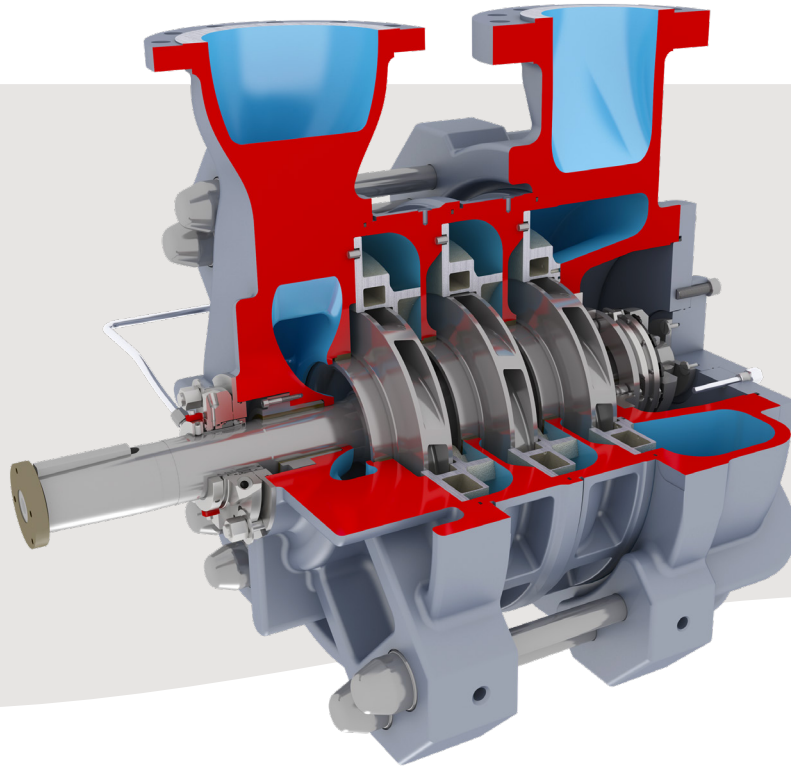

Long-term reliability with minimized operating expenses

The Flowserve CSX pump represents the next generation of multistage, segmental ring, diffuser-style membrane feed pumps.

Specifically engineered to meet desalination industry and operator preferences, the CSX pump is a step forward in design for efficiency and reliability. Its advanced hydraulics were designed using powerful computational fluid dynamics (CFD) software and then validated by testing to ensure top-of-class performance. Its optimized component design minimizes energy losses and prolongs operating life. The result is a highly reliable and efficient cost-effective feed pump for the heart of any reverse osmosis (RO) system.

Features and benefits

High-efficiency product lubricated bearings option enables world-class efficiencies while reducing pump complexity and minimizing maintenance and operating costs.

Precision cast impellers deliver high-efficiency performance and dimensional repeatability. The impellers are ring-less and individually dynamically balanced to achieve an assembled rotor balance grade of G2.5.

Easily replaceable wear rings are made with engineered thermoplastic and permit easy refurbishment of clearances to maintain high-efficiency operation and low lifecycle costs.

Precision cast diffuser and channel rings provide a continuous fluid passageway around the impellers without loss of efficiency. This design helps to balance radial loads so pump life is extended.

Axial thrust balance is achieved by applying a hydrodynamic axial bearing design which significantly reduces leakage/flushing rate and supports optimized pump efficiency.

Independently configurable nozzle heads are able to be rotated in 90-degree steps to suit a variety of piping layouts.

Stiff rotor design minimizes deflection, thereby increasing bearing and mechanical seal life.

Standardized mechanical seal chamber provides an optimal environment to prolong seal life without costly and complex auxiliary flush systems.

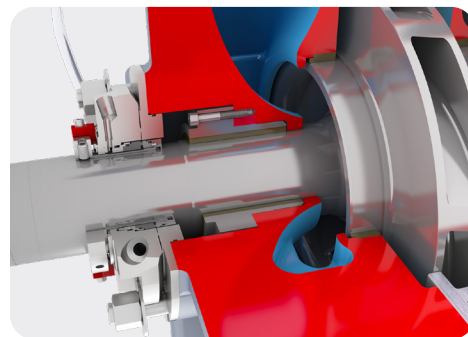

Single mechanical seal and precision cast diffuser and channel rings

Bearing configurations

Two pump configurations with different bearing lubrication designs are available to meet customer and application requirements.

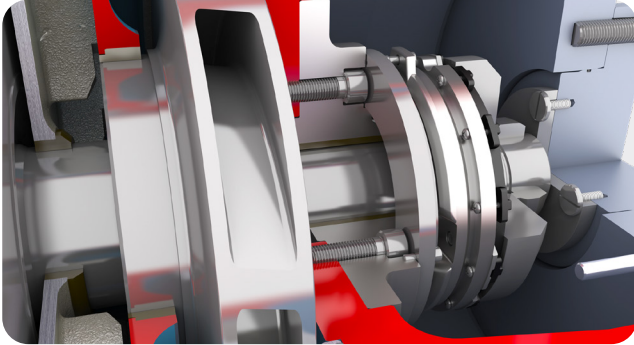

Fully product lubricated with hydrodynamic axial thrust and sleeve radial bearings

- Increases efficiency due to reduced losses
- Eliminates high-pressure seals, bearing housings, and use of oil or grease as a lubricant
- Reduces weight and number of components, which simplifies maintenance requirements and costs

Oil lubricated with sleeve radial and ball thrust bearings

- May be converted to product lubrication easily and with few modifications; contact Flowserve to learn how

Bearing cooling

- In seawater reverse osmosis (SWRO) applications, product water is used for cooling, so an external cooling water supply is not needed.

Typical applications

- Seawater and brackish water reverse osmosis desalination
- High-pressure membrane feed
- High-pressure filtered water applications
- Any other high-pressure applications with filtered liquids and ambient temperature

Operating parameters

- Sizes from 152 to 250 mm (6 to 10 in.)
- Flows to 1,500 m³/h (6,604 gpm)
- Heads to 840 m (2,756 ft)
- Design pressures to 100 bar (1,450 psi)
- Temperatures to 45°C (113°F)
- Frequency 50 or 60 Hz; VFD-compatible

Corrosion-resistant construction

Pitting, crevice corrosion and stress corrosion cracking are major challenges in processing seawater and brackish water. To maximize service life, wetted components of the CSX pump are available in a range of materials able to resist these aggressive forms of corrosion. These include ASTM A890 Grades 5A (standard) and 6A super duplex stainless steels.

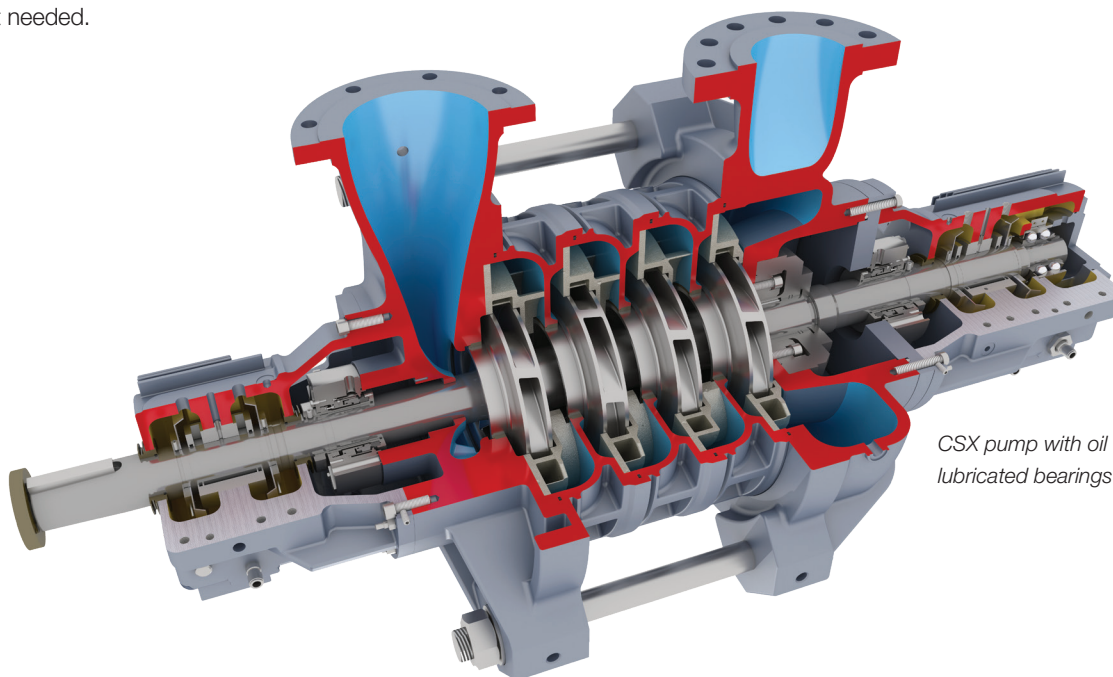

CSX pump with oil lubricated bearings



Optional instrumentation

The CSX pump is compatible with advanced internet of things (IoT) solutions such as RedRaven condition monitoring from Flowserve. Flowserve RedRaven IoT solutions give you the insights and tools you need to monitor, analyze and predict equipment performance — so you can improve pump uptime while reducing maintenance and energy costs.



Ask your Flowserve representative about optional RedRaven IoT monitoring packages or visit flowserve.com/iot to learn more.

Flowserve Corporation
5215 North O'Connor Blvd.
Suite 700
Irving, Texas 75039-5421 USA
Telephone: +1 937 890 5839

Flowserve Corporation has established industry leadership in the design and manufacture of its products. When properly selected, this Flowserve product is designed to perform its intended function safely during its useful life. However, the purchaser or user of Flowserve products should be aware that Flowserve products might be used in numerous applications under a wide variety of industrial service conditions. Although Flowserve can provide general guidelines, it cannot provide specific data and warnings for all possible applications. The purchaser/user must therefore assume the ultimate responsibility for the proper sizing and selection, installation, operation, and maintenance of Flowserve products. The purchaser/user should read and understand the Installation Instructions included with the product, and train its employees and contractors in the safe use of Flowserve products in connection with the specific application.

While the information and specifications contained in this literature are believed to be accurate, they are supplied for informative purposes only and should not be considered certified or as a guarantee of satisfactory results by reliance thereon. Nothing contained herein is to be construed as a warranty or guarantee, express or implied, regarding any matter with respect to this product. Because Flowserve is continually improving and upgrading its product design, the specifications, dimensions and information contained herein are subject to change without notice. Should any question arise concerning these provisions, the purchaser/user should contact Flowserve Corporation at any one of its worldwide operations or offices.

©2022 Flowserve Corporation. All rights reserved. This document contains registered and unregistered trademarks of Flowserve Corporation. Other company, product, or service names may be trademarks or service marks of their respective companies.

PUFLY000157-02 (EN/AQ) April 2022