



Worcester Tank Bottom Valve



Experience In Motion

DN8 - DN150

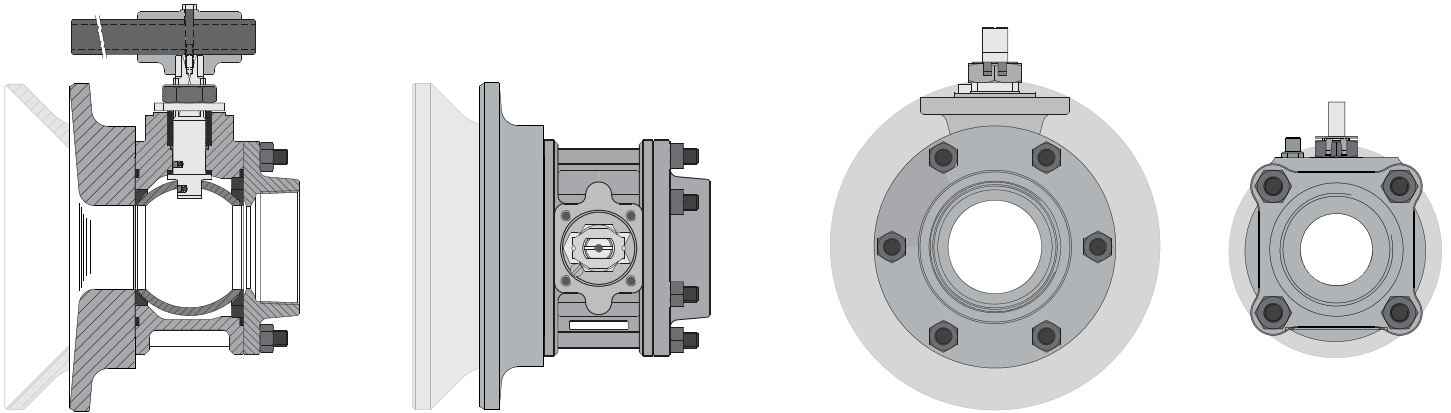

Tank bottom connector profiles are designed to suit individual customer requirements incorporating standard 44 and 459 valve bodies from sizes 8 - 50mm (44 series) and 65 - 150mm (459 series). Vessel mounting pad dimensions for some typical valve sizes are shown below. For further information please contact our technical sales department.

Typical Measurements for Interface

Valve size	N	R Ø	S	T THREAD	V Ø	W	X Ø	Y Ø	Z Ø
DN 50	66.68	10.6 10.4	22.4	M10 x 1.75P	N/A	12.05 11.80	38.23 38.10	70.6 70.1	80.7 79.7
DN 80	139.7	12.6 12.4	33.1	M12 x 1.75P	92.25 92.00	17.65 17.15	76.7 76.2	107.0	125.5 124.5
DN100	172.6	13.0 12.5	33.3	M12 x 1.75P	92.25 92.00	17.65 17.15	76.7 76.2	138.0	155.5 145.5

Flowserve Worcester offers tank bottom valves for a variety of applications:

- Industrial vessels
- Pharmaceutical Fermentation Reactors
- Primary Food Processing
- Cosmetics Mixing Vessels
- Biotech Reactors
- Petro-Chemical Processes
- Pressure Cookers on Food Processing

Standard Features

- Flush fit mounting flanges to eliminate media entrapment areas
Worcester's mounting flanges are designed to be welded flush into the tank bottom. They are also designed so that the ball closes up into the tank.
- Smooth tapered-bore mounting flanges eliminate media build-up
Worcester® has eliminated raised edges that can allow media build-up from the valve entry port. This is accomplished by radiusing the transition from the tank bottom to the valve entry port.
- Manual or automated operation
- A choice of seat & seal materials
- A Variety of downstream pipe ends
- All stainless steel materials with 316L mounting pad

FCD WCEBR0028-01 Printed in Germany.

Due to continuous development of our product range, we reserve the right to alter the dimensions and information contained in this leaflet as required. Information given in this leaflet is made in good faith and based upon specific testing but does not, however, constitute a guarantee.

Typical Interface Dimensions

DN50

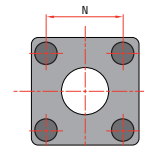
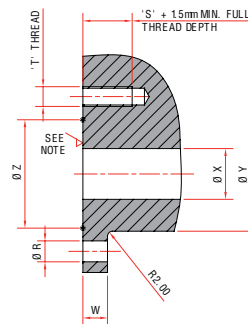

50mm VALVES: 4 BOLT SPACING.

DN80 - 100

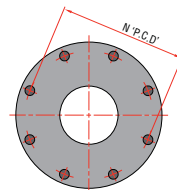
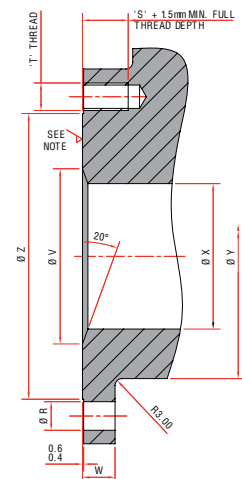

100mm VALVES: 8 BODY BOLT SPACING.
80mm VALVES: 8 BODY STUD SPACING.

NOTE: TO OBTAIN SATISFACTORY SEAL, SURFACE FINISH WITHIN Ø 'Z' ON PAD OR VESSEL MATING FACE TO BE BETTER THAN 1.6 µm IF ROTARY MACHINING OR 0.8 µm IF LINEAR.



Flowserve Flow Control.

A Division of Flowserve GB Ltd.
Burrell Road, Haywards Heath
West Sussex RH16 1TL
United Kingdom
Telephone: +44 (0)1444 314400
Telefax: +44 (0)1444 314401
Email: wvukinfo@flowserve.com