

Flowserve Standard Gas Control Panel A7x, N7x and C74 Gas Control Panel Series

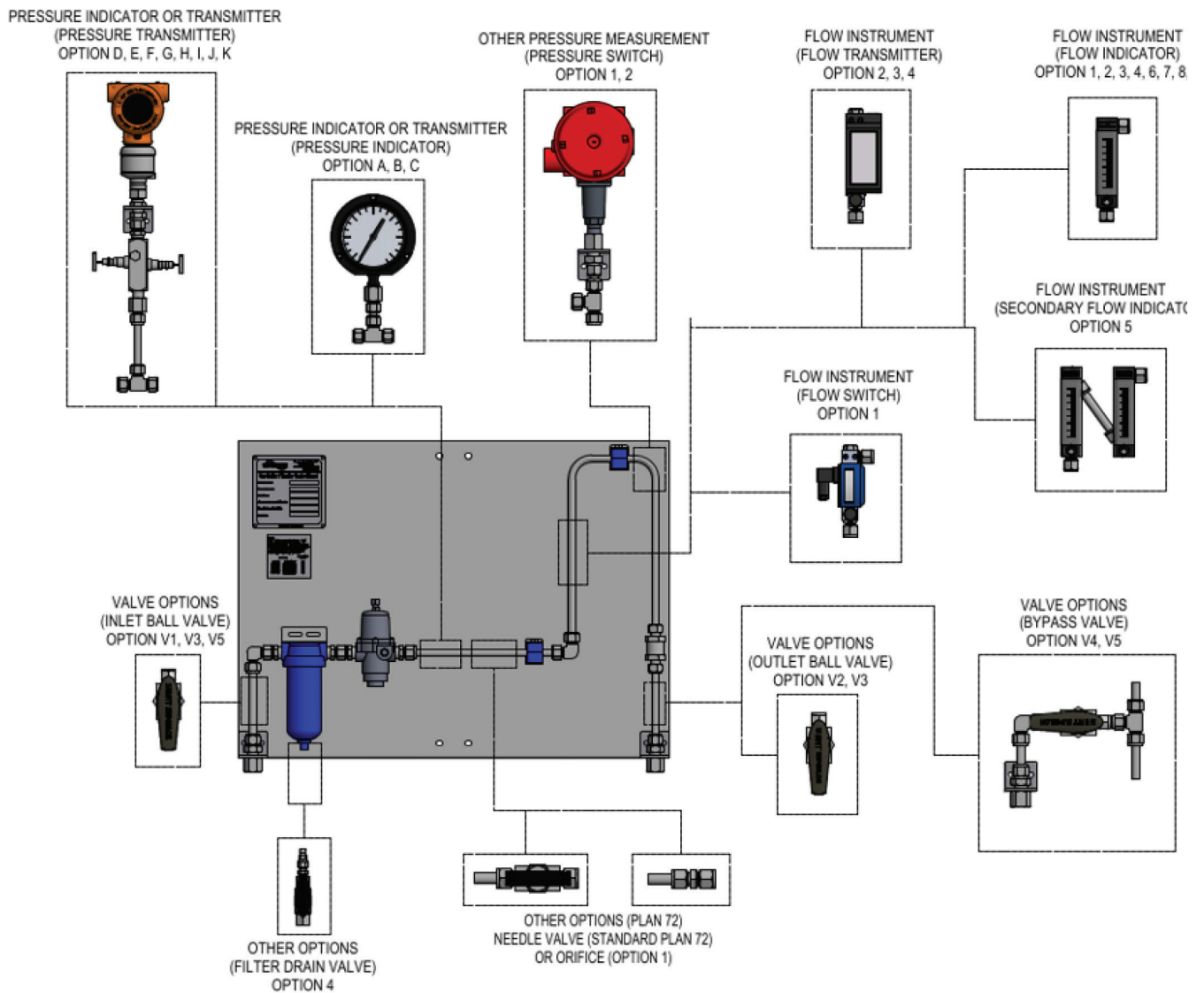

Flowserve Standard Gas Control Panel



This Manual contains regulations and drawings of a technical nature. No part of this document may be reproduced or distributed by any means, or used for competitive purposes, without the written consent of the publisher.

All information (including illustrations) in this manual is subject to change without prior notice. Flowserve does not accept any liability for any instance of damage or malfunction through non-adherence to these instructions.

CONTENTS

1 Introduction	3	6 Installation	9
1.1 About this manual	3	6.1 Introduction	9
1.2 How to use this manual	3	6.2 Safety considerations	9
1.3 Other supplied Documents	3	6.3 Installation requirements	9
1.4 Use of alerts and icons	3	6.4 Product Set-Up	9
2 Safety	4	6.4.1 Mounting	9
2.1 Types of hazardous exposures	4	6.4.2 Connections	10
2.2 General safety	4	6.4.2.1 X7x Gas Panel standard installation.	10
2.3 Trained and qualified personnel	4	6.4.2.2 X7x Gas Panel with auxiliary buffer gas connection.	10
2.4 Personal protective equipment (PPE)	4	6.4.2.3 X7x Gas Panel installed on Circpac seals	10
2.5 Actions in extreme conditions	4	6.4.3 Interconnecting piping	10
3 Environmental Considerations	4	6.4.4 Earthing	10
3.1 Disposing of waste products	4	6.4.5 Installation Procedure	11
3.2 End of life equipment	4	7 Operation	11
4 Description	5	7.1 Start-Up	11
4.1 Product purpose	5	7.2 Product Monitoring	12
4.2 Design Features	6	7.3 Shut-Down Product	12
4.3 Product components	6	8 Maintenance	13
4.4 The operating principle	7	8.1 General guidelines	13
4.5 Identifying the Product (Type Plate)	7	8.2 Periodic maintenance tables	13
5 Preservation, Packing, Transport and Storage Requirements	8	8.3 General guidelines	13
5.1 Mechanical preservation instructions	8	9 Troubleshooting	14
5.1.1 Preservation	8	ANNEX I	15
5.1.2 De-Preservation	8	ANNEX II	16
5.2 Packing	8		
5.3 Transportation and storage requirements	8		

1 Introduction

1.1 About this manual

This manual (which is intended for operating, maintenance, and supervisory personnel) provides information on installing, operating, and maintaining the A72-74, N72-74 and C74 Gas Panel Series (x7x).

Installation in accordance with the following instructions will contribute to long and trouble-free operation of the assembly.

1.2 How to use this manual

Before using this manual, make sure you have fully read and understood the safety section, which can be found in chapter 2. When being new to the x7x gas panel, pay attention to section 4, which describes the system in detail.

Only trained and qualified personnel should use this manual. Refer to section 2.3. Inexperienced personnel should only work on this system under the supervision of qualified personnel.

When maintaining the x7x gas panel, always make sure maintenance procedures are followed. Pay particular attention to the alerts and icons.

The x7x Gas Panel may only be used for its main purposes as described in this manual. No adjustments can be made without the approval of Flowserve.

Changes, modifications, repairs or use under conditions deviating from the design specifications without prior permission of Flowserve will make the declaration of conformity and the nameplate invalid.

1.3 Other supplied Documents

Annex II contains the assembly drawing and sub-component manuals.

1.4 Use of alerts and icons

This manual uses **NOTES**, **CAUTIONS**, **WARNINGS** and **DANGERS** to alert you of important information and/or hazardous situations.

NOTE: NOTES inform you of important additional information.

 **CAUTION: The equipment, product or surrounding area can be damaged if the “caution” is not obeyed.**

 **WARNING: Personnel can be (seriously) injured, or the equipment can be seriously damaged if the “warning” is not obeyed.**

 **DANGER: Personnel can be (seriously) injured if the “danger” sign is not obeyed.**

The above icons are the general icons that are used for **CAUTIONS**, **WARNINGS** and **DANGERS**. More specific icons are also used, depending on the type of hazard. All icons used in this manual are listed below:

 **WARNING HIGH PRESSURE: Take caution when de-pressurizing the x7x Gas Panel. The x7x Gas Panel might have energy stored inside. Make sure that de-pressurizing happens slowly.**

 **WARNING HOT SURFACES: The x7x Gas Panel and surrounding surfaces might be hot. Take care when touching components. Wear the appropriate Personal Protection Equipment (PPE), according to plant regulations**

 **WARNING HAZARDOUS CHEMICALS: Dangerous chemical might be released during removal of the x7x Gas Panel. Wear Personal Protective Equipment (PPE). Follow all safety regulations and Plant regulations.**

2 Safety

2.1 Types of hazardous exposures

The following hazards can be present in the x7x Gas Panel:

- High pressure
- Dangerous chemicals
- Temperature (hot surfaces)
- Dangerous moving parts (during installation)
- Electrical Hazards

If the X7x Gas Panel has any external leaks, the process in which the X7x Gas Panel is used should be stopped immediately and have the leak repaired by qualified personnel. When extreme conditions occur, and the possibility of a failure is imminent, plant-/end-user safety regulations shall be followed.

2.2 General safety

When installing, operating and maintaining the x7x Gas Panel, pay attention to the following:

- Obey all applicable safety laws and regulations.
- Obey all plant regulations.
- Make sure that only trained and qualified personnel work on it. Refer to section 2.3.
- Read and understand each part of this manual.
- Follow the installation, operation, and maintenance procedures exactly.
- Wear the relevant Personal Protective Equipment (PPE). Refer to section 2.4.
- Never work alone (if there is a possibility of an accident).
- Read the plant requirements for handling hazardous materials

2.3 Trained and qualified personnel

Qualified personnel are people who have been authorized by those responsible for the safety of the plant to perform the necessary work, and who can recognize and avoid possible dangers. The following aspects determine the qualification of personnel:

- Appropriate training
- Relevant experience
- Knowledge of relevant standards and specifications
- Knowledge of accident prevention regulations
- Knowledge of plant regulations and operating conditions

2.4 Personal protective equipment (PPE)

The X7x Gas Panel is often used for applications containing high-pressure, high-temperature and/or toxic chemicals. When performing operating or maintenance tasks, make sure you wear the appropriate Personal Protective Equipment (PPE): protective clothing, gloves, safety glasses, etc.

Always follow local regulations regarding PPE.

2.5 Actions in extreme conditions

In the unlikely event of emergency operating conditions always follow emergency plant regulations. Immediate evacuation of service personnel to be according plant regulations.

3 Environmental Considerations



CAUTION: You are required by law to dispose waste products and end of life equipment, according to local regulations.

3.1 Disposing of waste products

Make sure waste products are diverted to a safe and suitable location. Always follow local and plant regulations.

Any waste products resulting from the use or maintenance of the X7x Gas Panel must be disposed of according to local environment laws and regulations.

3.2 End of life equipment



WARNING HAZARDOUS CHEMICALS: Dangerous chemical might be released during removal of the X7x Gas Panel. Wear Personal Protective Equipment (PPE). Follow all safety regulations and Plant regulations.



WARNING HIGH PRESSURE: Take caution when de-pressurizing the X7x Gas Panel. The X7x Gas Panel might have energy stored inside. Make sure that de-pressurizing happens slowly.



WARNING HOT SURFACES: The X7x Gas Panel and surrounding surfaces might be hot. Take care when touching components. Wear the appropriate Personal Protection Equipment (PPE), according to plant regulations

When the equipment reaches the end of life, the shutdown procedure (section 7.4) shall be followed. The equipment must then be deinstalled and transported to a safe location. Always pay extra attention to safety!

NOTE: End of life equipment must be disposed of according to local environment laws and regulations.

4 Description

The x72 Gas Panel is designed to support arrangement 2 seals by maintaining buffer gas at a pressure not exceeding 0.7 BAR or 10psi. This gas is used to sweep out and remove inner seal leakage to another seal support system or to dilute emissions from the seal.

The x74 Gas Panel is designed to support arrangement 3 seals by maintaining a barrier gas pressure at least 1.7 BAR or 25psi above the seal chamber pressure. This gas is pressurized to make sure that hazardous or toxic gases from the seal are not allowed to escape to the atmosphere.

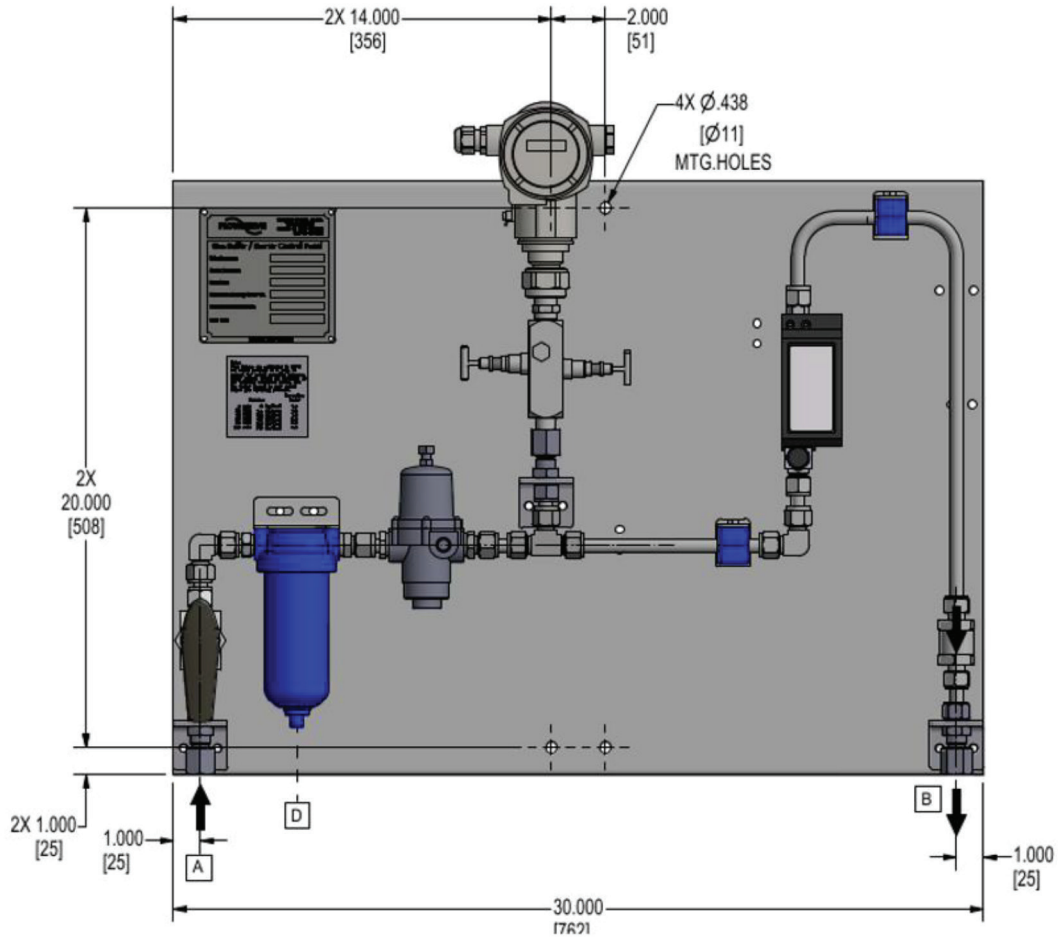

Figure 1: X7x Gas Panel – API Plan 74

4.1 Product purpose

The X7x Gas Panel, displayed in figure 1, is designed as standardized supply gas panel. These products are intended to supply clean nitrogen or air to appendix 2 and 3 seals. These are commonly used in conjunction with Plan 75 and Plan 76 auxiliary systems. The A7x Gas Panel is designed to comply with API 682 4th edition.

The purposes of the X7x Gas Panel in different applications are:

- To provide buffer gas into a seal to clear any escaped product and flush it to a Plan 75 for products that can condense, or Plan 76 for non-condensing gas.
- To provide barrier gas into a seal to serve as a high pressure source of gas to avoid any toxic or hazardous product gas from escaping the seal.
- To monitor and test seal health.

4.2 Design Features

Operating conditions may vary but shall never exceed the design conditions. Refer to the attached drawing of the X7x Gas Panel for boundary dimensions, design conditions and operating constraints.

The key design features of the X7x Gas Panel are listed below:

- API 682 4th edition compliant options available
- Meets ASME B31.3 design requirements
- Multiple ATEX classification up to II2G Ex ia IIC T6 Gb
- Multiple NEC/CSA classifications up to Class 1 Div 1 Gr ABC&D
- Back panel created from 316SS to be corrosion resistant.
- Compact universal design allows for the same footprint and connection location for all layouts.
- Compliance to Pressure Equipment Directive under SEP
- Compliance to CRN Canada-wide for most options
- Designed to withstand pressures up to 500PSIG (34 BarG), refer to attached drawing for design specifications.
- Designed to withstand temperatures up to 180F (82°C), refer to attached drawing for design specifications.

4.3 Product components

The X7x Gas Panel is an engineered seal system developed by Flowserve. For design specifics refer to the GA drawing. The parts and materials can deviate per design:

Number	Part	Function	Material
1	Coalescing Filter and Housing	Removes any particles and liquid that may be present in the buffer gas.	316 Stainless Steel / Aluminum
2	Pressure Control Valve	Adjusts the inlet buffer gas pressure to meet the seal requirements.	316 Stainless Steel / Aluminum
3	Pressure Instrument	Pressure gauge, Switch or Transmitter used for monitoring the buffer gas pressure.	316 Stainless Steel
4	Orifice or Needled valve	For A72 or N72, the device for setting the flow rate of the buffer gas into the seal.	316 Stainless Steel
5	Flow Instrument	Flow gauge, Switch or Transmitter used for monitoring the buffer gas flow rate into the seal.	316 Stainless Steel
6	Check Valve	Protection device to avoid reversal of buffer gas back into the panel in the event of a reversal from the seal.	316 Stainless Steel
7	Back Panel	Standardized panel for mounting and supporting all of the equipment required for the X7x Panel.	316 Stainless Steel

Table 1: X7x Gas Panel Components

4.4 The operating principle

The buffer gas, typically nitrogen or instrument air, is supplied to the inlet of the X7x Gas Panel where it is sent through a coalescing filter to remove any water droplets or particles. The buffer gas pressure is reduced as required for the application. Flow rate is controlled

with a needle valve or orifice and pressure and flowrate is monitored.

The pressure instruments are used for setting the initial gas pressure and the flow instrument is used for determining seal health.

Plan 74

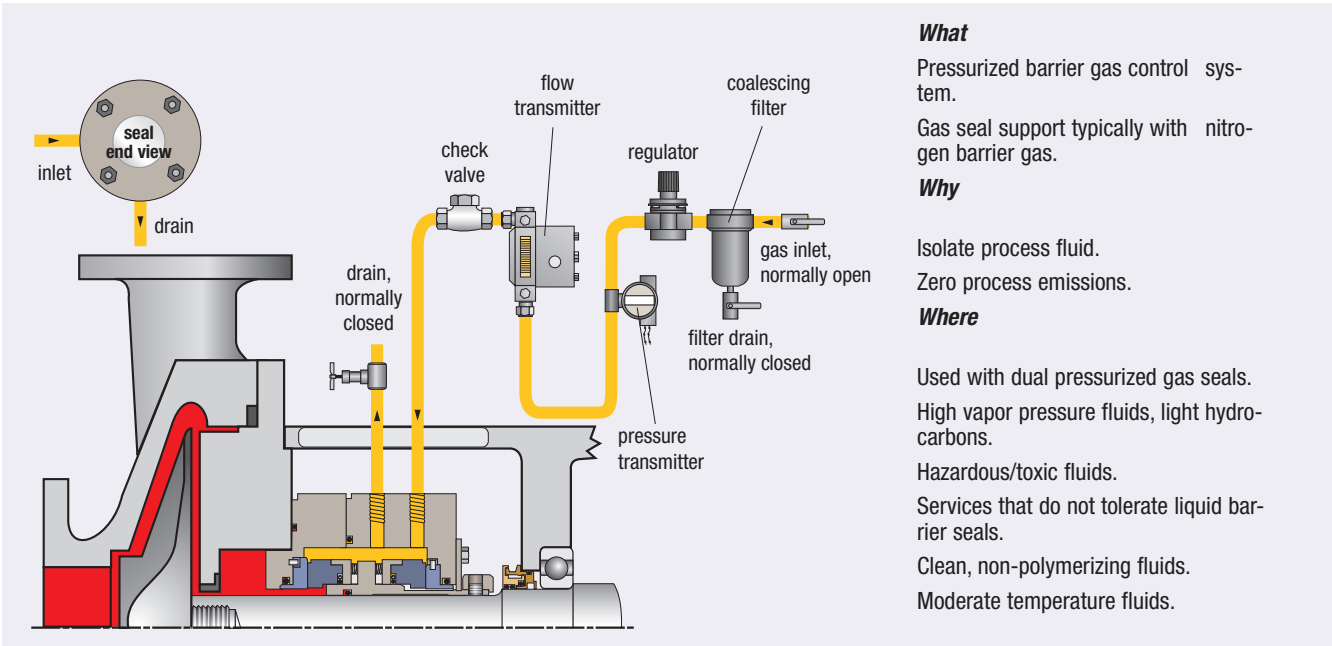

- What**
Pressurized barrier gas control system.
Gas seal support typically with nitrogen barrier gas.
- Why**
Isolate process fluid.
Zero process emissions.
- Where**
Used with dual pressurized gas seals.
High vapor pressure fluids, light hydrocarbons.
Hazardous/toxic fluids.
Services that do not tolerate liquid barrier seals.
Clean, non-polymerizing fluids.
Moderate temperature fluids.

Figure 2: Gas Panel operating principle

4.5 Identifying the Product (Type Plate)

The nameplate is, as per Flowserve standard, shown on the general assembly drawing. Plan 74 panels include an additional tag plate that indicates flow rate correction factor for higher operating pressures.

Note:
Flow Meters are calibrated in SCFH for outlet pressure of 0 psig. To correct for actual operating pressure, meter reading should be multiplied by the following correction factor. Use the factor closest to your actual buffer gas operating pressure.

Pressure		Correction Factor
0 PSIG	0 Kg/Cm2	1.0
20 PSIG	1.4 Kg/Cm2	1.5
40 PSIG	2.8 Kg/Cm2	1.9
60 PSIG	4.2 Kg/Cm2	2.3
80 PSIG	5.6 Kg/Cm2	2.5
100 PSIG	7.0 Kg/Cm2	2.8

Flowserve S. de R.L. de C.V.
Tlaxcala Systems
Phone: + 52 (246) 465-2600
01 (246) 465-2600

Gas Buffer / Barrier Control Panel

Inlet Pressure 200 PSI

Outlet Pressure 0 - 125 PSI

Part Code N74G1010A0V20

Flowserve Factory Order No. -

Manufacturer Serial No. -

Year Built 20**

PRODUCT OF MEXICO

Figure 3: Example of the Nameplate and Correction factor tag plate at X7x Gas Panel

5 Preservation, Packing, Transport and Storage Requirements

5.1 Mechanical preservation instructions

5.1.1 Preservation

Equipment should not be sealed in a way that it will obstruct inspection. Access for normal inspection and preservation maintenance shall be provided. Internal surfaces of pressure vessels, piping systems and similar equipment shall be dried and cleaned of surface corrosion and foreign material.

The X7x Gas Panel shall be thoroughly cleaned and dried after manufacturing and testing, prior to application of preservatives.

For equipment where water is used for cleaning or pressure testing, the water shall have antifreeze medium added unless the water is completely drained off. This also applies if the ambient temperature is below 4°C during any of these operations.

Internal surfaces wholly consisting of corrosion resistant materials shall not be preserved unless stated otherwise.

5.1.2 De-Preservation

For de-preservation the applicable dust caps/plugs need to be removed prior to commissioning. During hook up it is mandatory to keep these caps/plugs in place for as long as possible to prevent contamination.

5.2 Packing



WARNING CRUSH HAZARD: Possible injury and/or trapped limbs. Take care to avoid being trapped or crushed between heavy, moving objects when (un)boxing the panel.

The X7x Gas Panel is to be carefully lifted inside a timber box.

Always make sure that proper lifting devices are used.

To prevent damage during transport all equipment needs to be properly secured inside their timber package with suitable bolting, straps, or wooden supports.

For unboxing, the equipment must be lifted carefully out of its shipping box.

5.3 Transportation and storage requirements

NOTE: The following requirements apply to the X7x Gas Panel and all related equipment:

Transport and storage criteria	Requirements
Transportation	The system must be transported and stored in the unopened, original shipping box.
Suspect damaged during transportation	Inspect X7x Gas Panels that have been dropped or have been subjected to impacts during transport to confirm that they are operational before installation.
Warehouse requirements	The warehouse must be dry and dust free.
Long-term storage	After a storage period of 2 years, inspect the X7x Gas Panel before installation.
Preserving installed X7x Gas Panel Series	The preserving medium prevents damage to the installed system or mechanical seal (i.e. preventing fouling or chemical attack). Contact Flowserve if you are unsure which preserving medium to use.

Table 2: Transport and Storage Criteria

6 Installation

6.1 Introduction

⚠ WARNING CRUSH HAZARD: Possible injury and/or trapped limbs. Take care to avoid being trapped or crushed between heavy, moving objects when installing the panel.

Before installing the X7x Gas Panel, make sure you have read and understood the installation requirements in this section. If you have any questions regarding the installation of the X7x Gas Panel, contact your local Flowserve representative.

6.2 Safety considerations

⚠ WARNING CHECK BEFORE DISASSEMBLING: Under no circumstances should the X7x Gas Panel be disassembled while it still contains any hazardous materials or when it is pressurized.

⚠ DANGER SUFFOCATION HAZARD: Breathing hazardous chemicals in a confined space can result in sudden unconsciousness or death. Take extra care when working in confined areas.

Position the X7x Gas Panel as close to your main equipment as possible. Make sure there is sufficient room for:

- Evacuation of the plant in case of an emergency (do not block walkways and emergency exits)
- Safe operation and maintenance of the system
- If the X7x Gas Panel is being installed in a confined area, make sure there is adequate access for:
- Safe venting of the X7x Gas Panel interconnecting piping.
- Sufficient access for adjusting the flow components.
- Visual access (if required) to the pressure and flow instruments.

6.3 Installation requirements

Before installation the following shall be checked:

- Any possible damage due to transport or storage
- Cleanliness, required before operation.
- Existence of the nameplate with correct inspection markings and design/test conditions

6.4 Product Set-Up

6.4.1 Mounting

The X7x Gas Panel has two pairs of mounting holes located on top and bottom of the back plate. These holes are on the centerline and consist of 7/16" diameter (11mm) and spaced 2" (50mm) horizontally. These pairs will be 20" (508mm) apart vertically. This is designed to accept a 1/4" bolt (M6) and a 1" (25mm) spacer to mount it on a beam or flat surface. A vibration damping U-bolt can be used to secure this to a Nominal 1" (25mm) pipe, or it can be secured using a 1/2" (13mm) bolt to any stand or flat surface using the supplied adaptor bracket. All mounting holes should be used to secure the stand to avoid distortion or damage. If a grounding lug is required one of the four bolts can be used to secure it between the bolt head and the front of the back plate. See Figure 4 and GA drawings for more details.

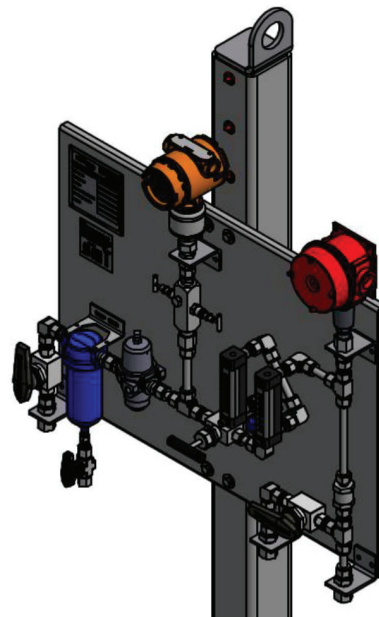

Figure 4: X7x Gas Panel with Mounting Holes mounted to Stand.

Mounting of the X7x Gas Panel should always comply to the points listed below:

- The X7x Gas Panel shall be mounted in a vertical position so that the flow instruments can function as designed.
- When mounting the X7x Gas Panel make sure that there is personnel access to the instrument and the controls.

6.4.2 Connections

When the X7x Gas Panel is mounted the interconnecting piping needs to be connected. Below, for each application in which the X7x Gas Panel could be used, is explained which utility needs to be connected to which X7x Gas Panel connection.

6.4.2.1 X7x Gas Panel standard installation.

When the X7x Gas Panel is installed in a standard arrangement, the inlet of the panel should be connected to the buffer gas source. This connection is ½" tube but can be changed as needed to connect to the buffer gas. The seal connection will be connected to the mechanical seal using ½" tubing. Filter drain can be connected to the facility drain or left unconnected.

6.4.2.2 X7x Gas Panel with auxiliary buffer gas connection.

When the X7x Gas Panel has an auxiliary buffer gas connection, this must be tied into a separate gas source or terminated with a quick connection for tie-in to a gas bottle. If this is intended for use with a gas bottle, ensure that a vent valve is added near the inlet of the panel to allow for purge of the line prior to operation.

6.4.2.3 X7x Gas Panel installed on Circpac seals

When the X7x Gas Panel is installed on a Circpac seals up to 10" (250mm), it is important that the inlet line be at least ¾" tube at minimum to avoid any restriction issues required for the larger flow demand required. Mixer seals exceeding this size should be evaluated by engineering to confirm line size.

6.4.3 Interconnecting piping

The flow of gas through the X7x Gas Panel is generated by:

- Buffer gas pressure sufficient to exceed all line losses and required max pressure including.

The interconnecting piping between the X7x Gas Panel and the main equipment must be correctly fitted; otherwise, the flow of the gas through the X7x Gas Panel will be restricted and have a negative impact on the performance.

Pay attention to the following points:

- Minimize the number of restrictions (for example, limit the number of elbow/tee fittings).
- The Filter and Regulator losses
- The Check valve cracking pressure
- The pipes must be clean and free of burrs.
- The total pipe length and number of bends shall be kept to a minimum.
- Tube runs should be sloped continuously up or down to allow for proper venting and draining in the event liquids migrate into the buffer gas.
- For threaded connections, do not use Teflon tape but an anaerobic thread sealant.
- Leak testing is recommended after assembly. Refer to end user specifications or procedures.

6.4.4 Earthing

Make sure the X7x Gas Panel is properly earthed. One of the back plate mounting bolts can be used as an earthing lug.



WARNING EXPLOSION RISK: Static electricity can build up and ignite flammable vapors. The system must be correctly earthed to minimize the risk of explosion caused by static electricity.

6.4.5 Installation Procedure

Use this procedure to install or reinstall the system.

1. Before installing the X7x Gas Panel, inspect all components for damage. If any of the components are damaged, you should report this to your local Flowserve representative. Refer to section 6.3.
2. Determine the installed position of the system. Refer to the mounting requirements, section 6.4.1.
3. The X7x Gas Panel can be moved by hand but can be moved by machine if needed. Use an appropriate lifting device to position the X7x Gas Panel as close as possible to the main equipment. Make sure you leave sufficient room for operation and maintenance purposes.



WARNING CRUSH HAZARD: Possible injury and/or trapped limbs. Take care to avoid being trapped or crushed between heavy, moving objects when installing the panel

4. Make sure that the X7x Gas Panel is installed in a rigid support to counteract any vibrations and instability.



WARNING HIGH PRESSURE: Take caution when de-pressurizing the X7x Gas Panel. The X7x Gas Panel might have energy stored inside. Make sure that de-pressurizing happens slowly.

5. Connect the X7x Gas Panel connections. Refer to section 6.4.2.
6. Manufacture the interconnecting piping according to the Installation requirement. Refer to section 6.4.3.
7. Make sure the installation is correctly earthed to prevent the potential risk of explosion caused by static electricity.
8. Connect the instruments and/or switches to their respective control devices.

NOTE: Leak testing is recommended after assembly. Refer to end user specifications or procedures.

7 Operation

7.1 Start-Up

Use this procedure if:

- The X7x Gas Panel is being set-up for the first time, or
- The X7x Gas Panel gas has been completely vented from the system.

When the X7x Gas Panel is installed, the application can be started up. The below procedure shall be used for starting up the X7x Gas Panel.

1. Review the minimum/maximum system pressures that might be encountered at the following:
 - a. Buffer gas supply system pressure
 - b. Seal Chamber pressure (for P74)
 - c. Vapor/Liquid collection system pressure (for P72)
2. Confirm that all connecting piping, fittings, indicators and accessories are rated properly.
3. Confirm the hazardous area classifications where the X7x Gas Panel is to be installed and that the instruments meet or exceed the classification.
4. Inspect all connections for dirt or contamination. Remove according to end-user/plant regulations.
5. Ensure that plugs or block valves are installed in the panel and seal drains.
6. Make sure commissioning of the system has been performed properly and that all connections are secure.
7. Turn on buffer gas to the X7x Gas Panel
8. Start up the pump according end user/plant procedures.
9. For Plan 74 systems: adjust the pressure regulator until the pressure gauge reads a predetermined pressure above the seal chamber pressure, taking into consideration all phases of equipment operation.
For Plan 72 systems: adjust the pressure regulator unit the pressure indicator reads a predetermined pressure nominally above atmospheric or vapor/liquid collection system pressure.
10. Adjust the needle valve on the panel or the flow instrument until it is reading 1 SCFH per 1 in of seal diameter or 0.2 SLPM per CM of seal diameter.
11. Pressure alarm settings for Plan 74 systems should be set to at least 25 PSI (1.7 BAR) above seal chamber pressure as a Low alarm. Plan 72 systems should be set for 10 PSI (0.7 BAR) above nominal pressure as a High alarm .
12. Flow alarm settings should be set to 2 SCFH above nominal flow rate High.

7.2 Product Monitoring

 **WARNING HIGH PRESSURE:** Take caution when de-pressurizing the X7x Gas Panel. The X7x Gas Panel might have energy stored inside. Make sure that de-pressurizing happens slowly.

 **WARNING HOT SURFACES:** The X7x Gas Panel and surrounding surfaces might be hot. Take care when touching components. Wear the appropriate Personal Protection Equipment (PPE), according to plant regulations

 **WARNING HAZARDOUS CHEMICALS:** Hazardous chemicals might be released during removal of the X7x Gas Panel. Wear Personal Protective Equipment (PPE). Follow all safety regulations and Plant regulations.

Use this procedure to monitor the system:

1. Monitor the X7x Gas Panel for correct operation. Also refer to the Periodic maintenance tables in section 8.2.
2. Make sure:
 - there are no leaks.
 - The filter is not capturing and draining excessive moisture.
 - there is stable pressure on the panel once the regulator is set.
 - there is proper buffer gas flow and it is stable after being set.
3. If you notice any problems with the X7x Gas Panel, follow plant regulation for reporting and correcting faulty equipment.
4. Pressure should remain on the seal even when the pump is not running.

X7x Gas Panel performance should be monitored periodically. Baseline flow rates and pressures should be collected soon after equipment commissioning.

Periodically the X7x Gas Panel pressure and flow should be monitored to confirm seal condition.

7.3 Shut-Down Product

 **WARNING HIGH PRESSURE:** Take caution when de-pressurizing the X7x Gas Panel. The X7x Gas Panel might have energy stored inside. Make sure that de-pressurizing happens slowly.

 **WARNING HOT SURFACES:** The X7x Gas Panel and surrounding surfaces might be hot. Take care when touching components. Wear the appropriate Personal Protection Equipment (PPE), according to plant regulations.

 **WARNING HAZARDOUS CHEMICALS:** Hazardous chemicals might be released during removal of the X7x Gas Panel. Wear Personal Protective Equipment (PPE). Follow all safety regulations and Plant regulations.

The X7x Gas Panel may be disconnected only by qualified personnel, in accordance with national, plant- and end-user safety regulations and Chapter 2 in this manual.

Check if the X7x Gas Panel can be shut down. Check if the X7x Gas Panel can be de-pressurized without negatively affecting the mechanical seal installed in main equipment. System cannot be shut down if any of the following main equipment conditions occur:

- Main equipment/ Pump is on hot stand-by.
- Main equipment/ Pump is pressurized.
- Main equipment/ Pump is in operation.

NOTE: Always shut down the system according to plant regulations/ end user safety procedures.

If the above points are checked, the X7x Gas Panel can be shut down according to the procedure below:

- Make sure the pump is shut down according to end-user/plant regulations.
- Isolate the buffer gas from the panel and to the seal.
- De-pressurize the X7x Gas Panel

NOTE: For (re)-installation, removal and maintenance work, the X7x Gas Panel must be de-pressurized (and drained if required).

8 Maintenance

8.1 General guidelines

Periodic maintenance must be done at regular intervals (weekly, monthly, yearly). Refer to the following tables.

All liabilities and warranties to Flowserve for damage incurred using non-original replacement parts and accessories will be rendered null and void.

To avoid potential explosion hazards during maintenance, the tools, cleaning and painting materials used must not give rise to sparking or adversely affect the ambient conditions. Where there is a risk from such tools or materials the Gas Panel must be moved to a safe area for dismantling.

8.2 Periodic maintenance tables

Use the following tables to plan the periodic maintenance for your system (refer to the table of contents and the Appendix for the relevant information)

Weekly maintenance
Check the seal, X7x Gas Panel, and interconnecting pipe work for leaks. Rectify if necessary.
Drain and check the filter for any liquids.
Check the Pressure and Flow and confirm that they are stable.

Monthly maintenance
Do all weekly periodic maintenance procedures.
Check all optional earthing connections. Rectify if necessary.
Check all electrical connections to confirm that no damage has occurred.

Yearly maintenance
Do all weekly and monthly periodic maintenance procedures.
Replace the filter element.

Table 3: Periodic Maintenance Tables

8.3 General guidelines



WARNING HIGH PRESSURE: Take caution when de-pressurizing the X7x Gas Panel. The X7x Gas Panel might have energy stored inside. Make sure that de-pressurizing happens slowly.



WARNING HOT SURFACES: The X7x Gas Panel and surrounding surfaces might be hot. Take care when touching components. Wear the appropriate Personal Protection Equipment (PPE), according to plant regulations.



WARNING HAZARDOUS CHEMICALS: Hazardous chemicals might be released during removal of the X7x Gas Panel. Wear Personal Protective Equipment (PPE). Follow all safety regulations and Plant regulations.

The product maintenance procedure is as follows:

- Remove the X7x Gas Panel from service. Refer to section 7.3. Shut-Down Product.
- Internally and externally clean the X7x Gas Panel without damaging the equipment. The tubing can be removed as needed but follow the manufactures reassembly process for reassembly.
- Inspect all components for damage or corrosion and replace as needed.
- Re-install the X7x Gas Panel. Refer to section 6.5. Installation Procedure.

9 Troubleshooting

Use the following table to troubleshoot the system. Once you have identified the problem, use the procedures in this manual to maintain the X7x Gas Panel. If you are not sure how to troubleshoot or maintain your X7x Gas Panel, please contact your local Flowserve representative.

NOTE: the recommended response actions always include notify the supervisory authority and respond according to plant regulation.

Parameter	Indication	Possible Cause	Solution
Pressure	Low	<ul style="list-style-type: none"> Leakage in connections, gaskets, piping Mechanical seal failure Buffer gas source supply pressure fails. 	<ul style="list-style-type: none"> Check connections for leakage. Check gaskets for leakage. Check piping for leakage. Check mechanical seal
Pressure	High	<ul style="list-style-type: none"> Inner mechanical seal failure Process discharge closed. 	<ul style="list-style-type: none"> Repair mechanical seal Open discharge line
Flow	Low	<ul style="list-style-type: none"> Inner mechanical seal failure. Needle valve closed or orifice plugged. Buffer gas source supply pressure fails. 	<ul style="list-style-type: none"> Check for blockages. Adjust needle valve. Localize blockage.
Flow	High	<ul style="list-style-type: none"> Inner mechanical seal failure. Needle valve incorrectly adjusted 	<ul style="list-style-type: none"> Adjust needle valve. Check mechanical seal

Table 4: Localization and Elimination of Vaults, Damages and their Consequences

ANNEX II

Page is left blank intentionally

Page is left blank intentionally

Page is left blank intentionally



Flowserve Corporation
5215 North O'Connor Blvd.
Suite 700
Irving, Texas 75039-5421 USA

SSIOM001519-00 (EN/A4) July 2024

Flowserve Corporation has established industry leadership in the design and manufacture of its products. When properly selected, this Flowserve product is designed to perform its intended function safely during its useful life. However, the purchaser or user of Flowserve products should be aware that Flowserve products might be used in numerous applications under a wide variety of industrial service conditions. Although Flowserve can provide general guidelines, it cannot provide specific data and warnings for all possible applications. The purchaser/user must therefore assume the ultimate responsibility for the proper sizing and selection, installation, operation, and maintenance of Flowserve products. The purchaser/user should read and understand the Installation Instructions included with the product, and train its employees and contractors in the safe use of Flowserve products in connection with the specific application.

While the information and specifications contained in this literature are believed to be accurate, they are supplied for informative purposes only and should not be considered certified or as a guarantee of satisfactory results by reliance thereon. Nothing contained herein is to be construed as a warranty or guarantee, express or implied, regarding any matter with respect to this product. Because Flowserve is continually improving and upgrading its product design, the specifications, dimensions and information contained herein are subject to change without notice. Should any question arise concerning these provisions, the purchaser/user should contact Flowserve Corporation at any one of its worldwide operations or offices.

©2024 Flowserve Corporation. All rights reserved. This document contains registered and unregistered trademarks of Flowserve Corporation. Other company, product, or service names may be trademarks or service marks of their respective companies.