

AXIAL FIELD INTEGRAL MOTOR PUMPING SYSTEM

Advanced Pumping System Technology

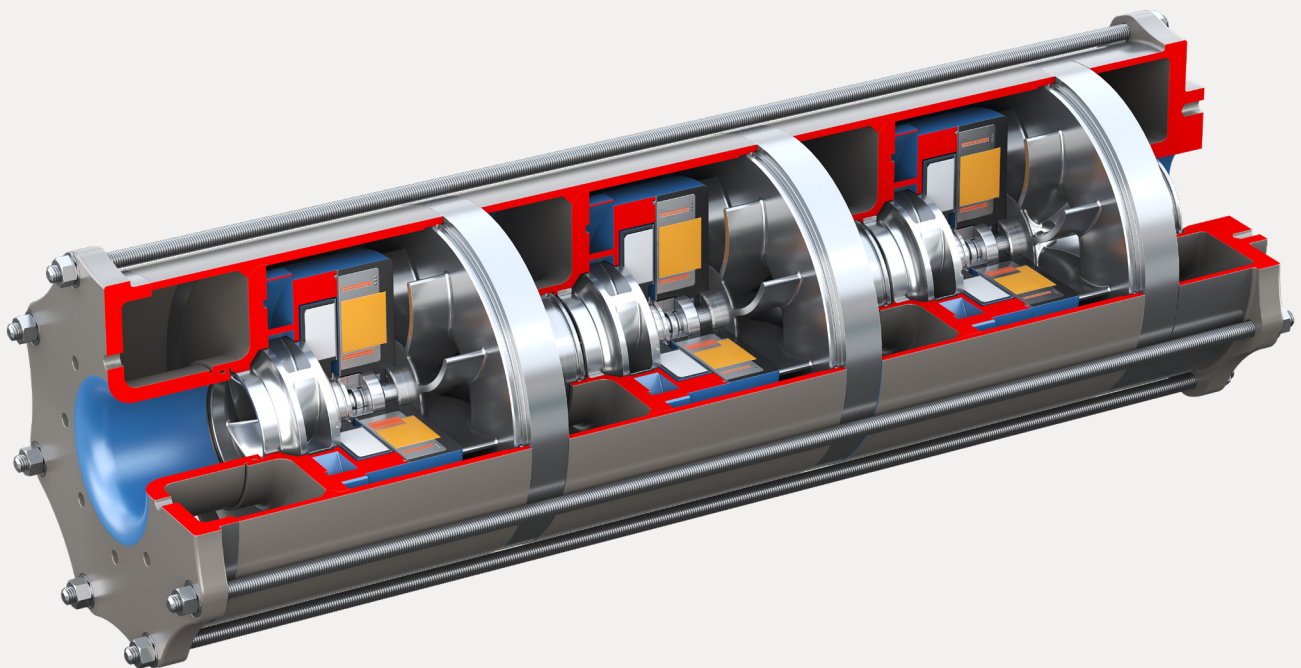

Introduction

Pumping systems are a critical component within the flow control industry. As the industry transforms towards a decarbonized, modularized, and digitized future, Flowserve's advanced pumping system technology will become a standardized solution. Advanced pumping systems will increase value, reduce energy consumption, and lower the life cycle costs throughout the lifespan of the pumping system.

Decarbonization

As environmental regulations continue to tighten, industry players need to drastically reduce their CO2 emissions to meet new targets. To save cost and simplify system controls, new products will need to autonomously regulate to achieve the most energy efficient output.

Modular processes

Advanced process industries and energy systems are moving toward modular technologies to simplify plant operations and significantly reduce capital investments. Modular construction shortens on-site installation, repairs and replacements allowing customers to generate revenue at accelerated rates.

Digitization

Advanced digital systems will be key in making energy-producing assets more efficient, resilient and sustainable while helping manufactures reduce waste. A strategic combination of multiple smart hydraulic technologies and intelligent control systems will bring clear and quantifiable benefits which will yield exceptionally short payback periods.

Life cycle cost

Industry players need simplified and cost-effective pumping solutions. Transformation trends are driving new technologies to be more efficient, reliable and intelligent. Operators are seeking to lower the total cost of owning and operating pumping systems, by reducing installation, and maintenance costs while simultaneously decreasing operating energy costs.

Introducing an advanced pumping system technology: Axial Field Integral Motor Pumping System

Technology Summary

A multi-stage sealless pumping technology offers a simplified approach to product operation. Each modular stage comprises an integrated motor system that is completely isolated and independently controlled. Modularized hydraulic components are fixed to each motor and can be easily exchanged to achieve various duty conditions. Each motor contains an uncoupled rotor equipped with an individual product lubricated bearing. These stages do not operate with a common shaft which keeps the rotor very compact, eliminating typical long-shaft rotordynamic and misalignment issues. The motors are operated by Variable Speed Drives which allow for precise speed controls and greater operational flexibility.

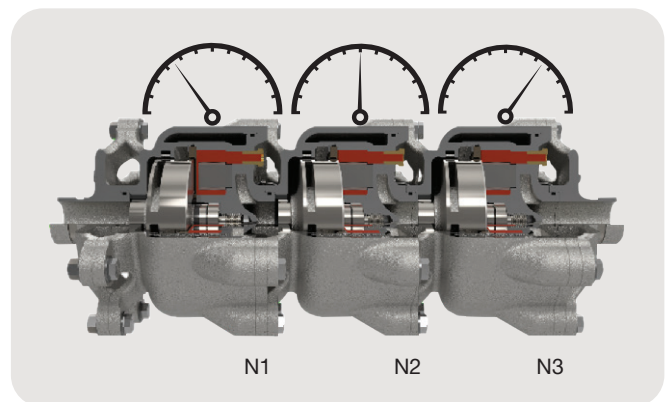

3-Stage Axial Field Integral Motor Pumping System - Flanged Design

Technical description

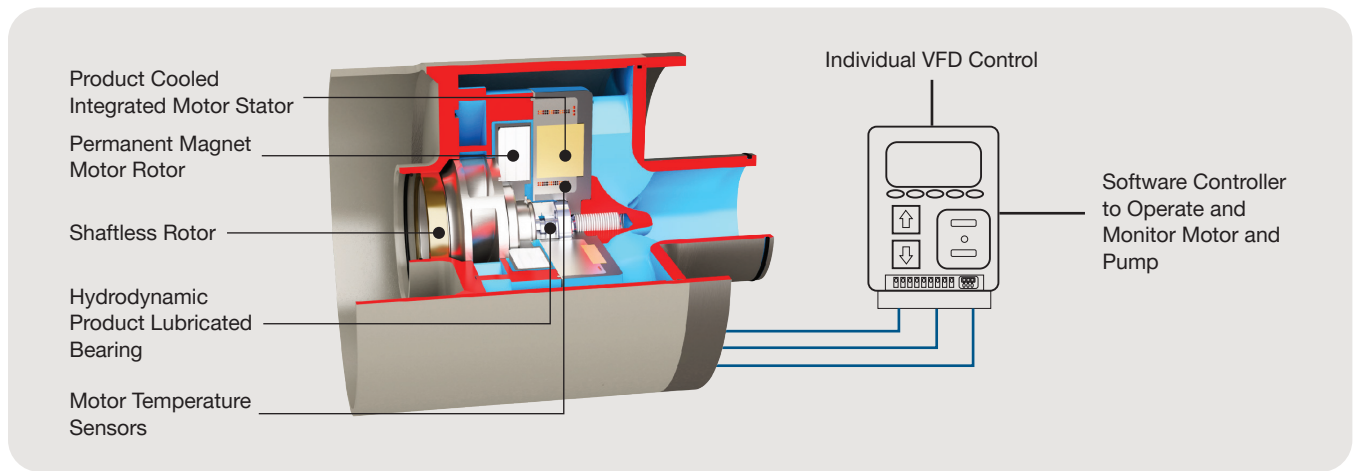

Single Stage Axial Field Integral Motor Pumping System - Tie Rod Design

High Efficiency Axial Field Permanent Magnet Motor

The axial field motor offers a superior efficiency with higher power density, resulting in a lower weight in a smaller envelope when compared to a similarly rated conventional induction motor. This allows the Integrated Motor Pump to offer a highly efficient motor at a fraction of the size.

The heat generated within the motor stator is rejected by the passing product fluid, allowing for even higher power densities when compared to traditional air-cooled motors. Several temperature sensors can be embedded within the motor stator to monitor motor health in real-time, and track motor life expectancy.

Variable Frequency Drive (VFD)

Each motor stage can be controlled with an individual VFD, electrically isolating each stage from one another. This allows each stage to operate independently of one another, allowing for individual speed control per stage.

Monitoring of unexpected operating conditions is made easy by the VFD safety controls. By detecting unanticipated loads, the VFD can safely initiate a shutdown to avoid damaging the pump.

Magnetic Thrust Compensation

The magnetic field created by the permanent magnet motor rotor has an interacting force with the ferromagnetic materials within the motor stator. This force keeps the rotor at the

desired position and prohibits any rotor axial movement. This allows the rotor to be unaffected by excessive thrust loads, preventing rotor shuttling and bearing overloading.

Shaftless Rotor

The rotor rotates around a fixed positioning stud which eliminates common rotor dynamic issues. This compact rotor results in a simplified design when compared to conventional shaft driven pumps; generating much less vibrations, lower fatigue stresses, and lower noise levels. As the rotor is completely contained within the pump housing only the differential pressure transmits thrust to the rotor, allowing the design to be unaffected by high suction pressures.

Product Lubricated Bearing System

Each stage contains an individually isolated bearing system, including a hydrodynamically lubricated bearing that does not require any external lubrication. These hydrodynamic bearings offer very low power consumption at a longer rated life than traditional contact bearings. Bearing materials include: Silicon Carbide, Stainless Steel, Graphite, and several thermoplastics.

Smart Controlling Software

A custom-built PID logic controller can be tailored to communicate between customer sensors and the VFD system. By implementing an intelligent pumping profile, the logic controller can autonomously operate a single or multistage motor pump system in accordance with customer operating needs. Intelligent pumping operation can dynamically respond to various operating disturbances, modifying stage speed to achieve the desired output.

Cluster arrangements

The 'Axial Field Integral Motor Pumping System' is a highly modular design, enabling easy system integration and flexible operation. This technology is highly compatible for cluster arrangements.

In such cluster arrangements, multiple stages can be installed in series and in parallel, acting as pumps and/or turbines based on the process requirements. The speeds and operating modes can be entirely process controlled. Thereby, the process- and round trip efficiencies can be optimized. Adjustment of the pump/turbine configuration in response to changing process requirements can easily be realized simply by the variation of stage count of the units and/or algorithms.

In a cluster arrangement, the pumps/turbines are no longer isolated hydraulic components but become a truly integrated pumping systems, controlled by-and optimizing the process.

Traditional Pump Configuration

- One-directional energy flow

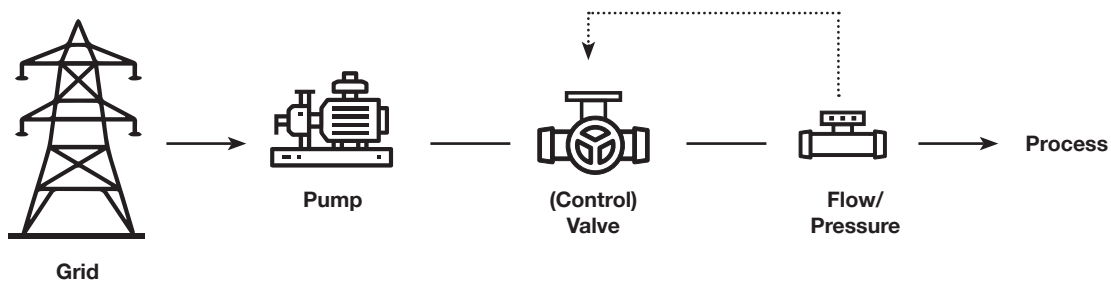

AF-IMP Cluster

- Multi-directional energy flow
- Process Optimization
- Round Trip Efficiency Optimization

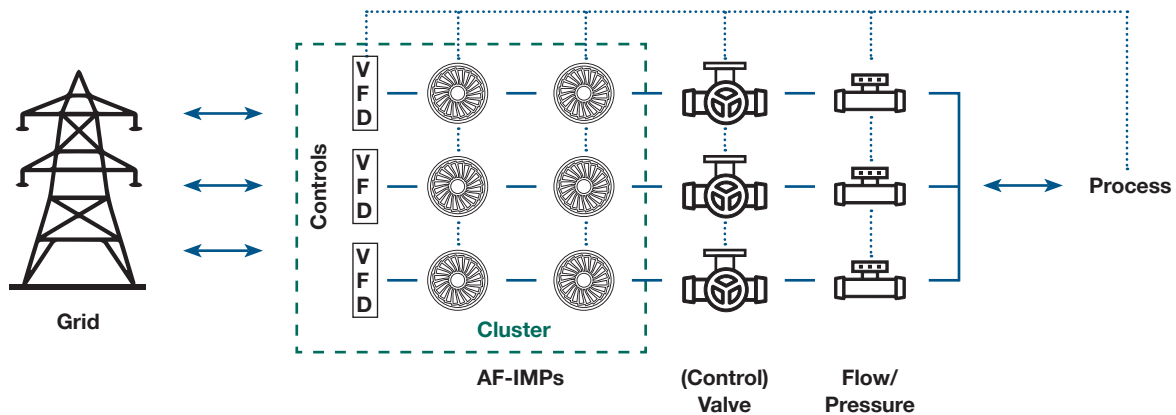

Key system benefits

Energy Savings

Reducing Power Losses

By varying the stage speed, pumping systems can operate closer to best efficiency conditions and eliminate excessive throttling. Limiting off-design operation prevents damage to pumping components, increasing product lifespan and reducing process disruptions. Speed modifications can be utilized in place of control valves, reducing the overall system power consumption by increasing the operational flexibility.

System & Equipment Simplification

Reduced Maintenance Schedule

By integrating the motor within the pump casing many expensive components can be eliminated, such as: seals, couplings, external bearing systems, baseplates and common shafts. The only components that will need regular maintenance will be the wear ring and product lubricated bearing.

Modular Construction

Hydraulic and motor components come in standardized sizes and can easily be exchanged or replaced. Flange connections are highly adaptable and can be tailored to fit a variety of piping connections. The compact design saves transportation and installation costs with a smaller, more portable product package.

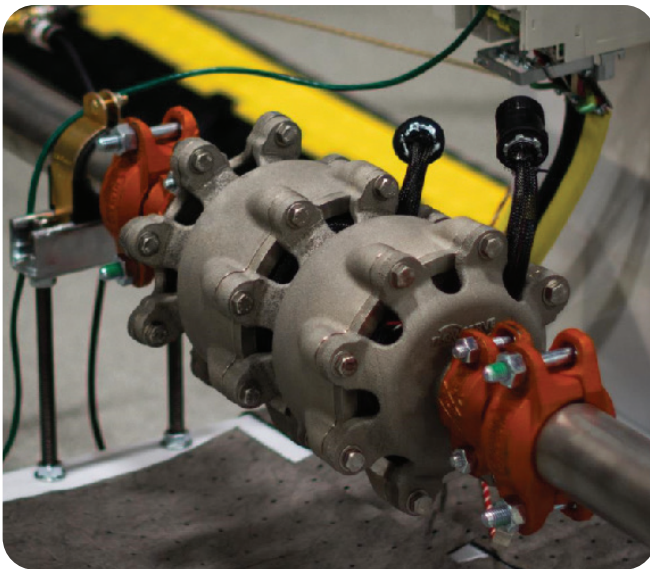

2-Stage Axial Field Integral Motor Pumping System

Intelligent Controls

Integrated Safety Features

Integrated controls allow for improved safety management features. Self-protecting systems are used to prevent hazardous operation conditions like cavitation, overheating, and vibration with simple real-time monitoring and diagnostic techniques.

Automated System Controls

Control systems tailored for specific customer applications can be designed to respond to a variety of changing conditions and process disturbances. Given a set of priority assignments, the control system can consist of multiple call functions that operates the pumping system to exactly the system requirements.

Fault Tolerant Operation

Traditionally, in a multistage pump, if a single stage fails then the entire pumping system will cease to operate. With a modularized multi-stage design the system could persist through a stage failure. In this event power will be disconnected, and the remaining stage speeds will be increased to recover any loss in pumping power. This critical service feature prevents a system shut-down as the multi-stage pump inherently contains built-in spare units.

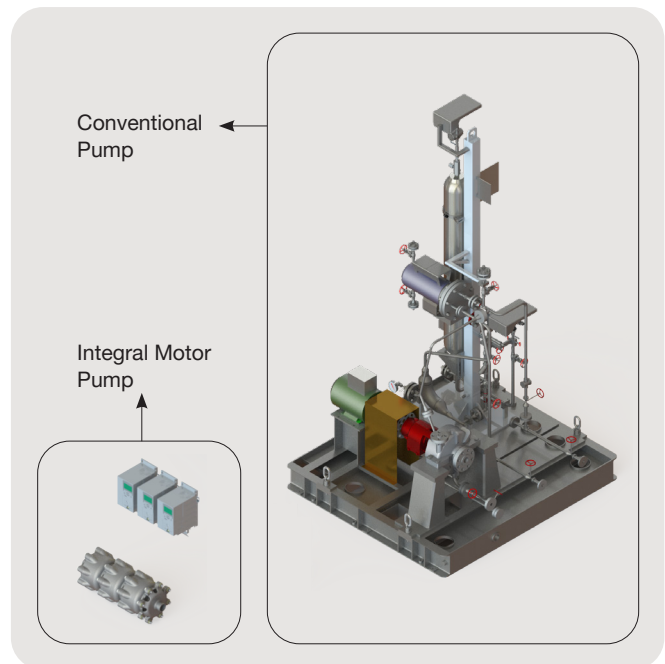



Conclusion

The many benefits of this technology can significantly reduce the total ownership cost throughout the product lifespan. Self-adjusting operation coupled with a compact robust design ensures critical service operation remains uninterrupted. This technology is a pumping system re-imagined, a next generation problem solver that eliminates common multistage issues while handling a variety of disturbances.

The system is comprised of individual technologies and design features that are widely used with great success across multiple industries, when combined the resulting package offers a very competitive product. Adaptation to increasingly diverse requirements necessitates an innovation, and Flowserve is proud to deliver this technology as a sustainable pumping system for the future!



5-Stage Axial Field Integral Motor Pumping System Tie Rod Design

Flowserve Corporation
5215 North O'Connor Blvd.
Suite 700
Irving, Texas 75039-5421 USA

Flowserve Corporation has established industry leadership in the design and manufacture of its products. When properly selected, this Flowserve product is designed to perform its intended function safely during its useful life. However, the purchaser or user of Flowserve products should be aware that Flowserve products might be used in numerous applications under a wide variety of industrial service conditions. Although Flowserve can provide general guidelines, it cannot provide specific data and warnings for all possible applications. The purchaser/user must therefore assume the ultimate responsibility for the proper sizing and selection, installation, operation, and maintenance of Flowserve products. The purchaser/user should read and understand the Installation Instructions included with the product, and train its employees and contractors in the safe use of Flowserve products in connection with the specific application.

While the information and specifications contained in this literature are believed to be accurate, they are supplied for informative purposes only and should not be considered certified or as a guarantee of satisfactory results by reliance thereon. Nothing contained herein is to be construed as a warranty or guarantee, express or implied, regarding any matter with respect to this product. Because Flowserve is continually improving and upgrading its product design, the specifications, dimensions and information contained herein are subject to change without notice. Should any question arise concerning these provisions, the purchaser/user should contact Flowserve Corporation at any one of its worldwide operations or offices.

©2024 Flowserve Corporation. All rights reserved. This document contains registered and unregistered trademarks of Flowserve Corporation. Other company, product, or service names may be trademarks or service marks of their respective companies.

PUWP001298 (EN/AQ) April 2024